

1.Scope

This Instruction sheet shows about the 025 LOW PROFILE Connector.

Applicable product description and part numbers are as shown in Fig.1

2. Part Name and Part Number

2.1 Housing

TE Part No.* ¹	Description
1612048	025 low profile Connector 24POS. CAP ASSY (Male Connector)
1612050	025 low profile Connector 32POS. CAP ASSY (Male Connector)
1612052	025 low profile Connector 40POS. CAP ASSY (Male Connector)

Fig.1

*¹ Note: Part number is consisted from listed base number and 1 digit numeric prefix and suffix with dash.

Refer to catalog or customer drawing for specific part numbers for each base number.

When prefix is zero, zero and dash are omitted.

2.2 Plug Housing To Be Mated: SUMITOMO WIRING SYSTEMS CO.LTD.

Customer Part No. * ²	Description
90980-12404	0.64 II CONNECTOR(low profile type) 24POS. PLUG ASSY (FEMALE CONNECTOR)
90980-12422	0.64 II CONNECTOR(low profile type) 32POS. PLUG ASSY (FEMALE CONNECTOR)
90980-12388	0.64 II CONNECTOR(low profile type) 40POS. PLUG ASSY (FEMALE CONNECTOR)

Fig.2

*²Inquire the applicable manufacturer about 0.64 II low profile female connector & contact.

2.3 Components View

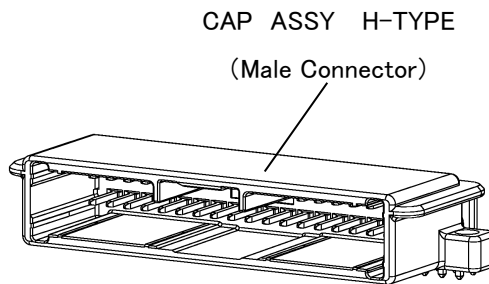

Fig.3

3. Customer Receiving Inspection

We conduct inspections according to our quality control regulations to maintain an over all lot control. In addition, the customers should conduct receiving inspections based on the specific customer drawings.

4. Storage and Carrying

4.1 Housing

- (1) It is desired that the products are placed where the temperature is ranging between 5~35°C with the relative humidity ranging between 45~85%.
- (2) It is advised that leaving the products in open air for a long time tends to get contaminate by dust and particles.
Leaving under the open air for a long time should be forbidden from this point of view.
- (3) Do not drop or shock the housing when carrying it.

5. Fixing Housing and PC Board

Insert the contact of the male connector into the hole of PC Board. Then after fixing the housing and the board with a screw, solder the contacts. And take care of the following at the work.

- (1) See the customer drawing for the PC Board dimension.
- (2) Do not deform the contact (PC Board side), otherwise the male connector can not be fixed on the PC.Board.
- (3) The fixing should be made with the proper type of screw and torque.
Recommended Screw: JIS B1115, B1122, TAPPING SCREW, PAN HEAD, CLASS2, M3 × 6
Recommended Torque: See the customer drawing.
Torque for operation should be provided respectively by using the combination of the parts, PC.Board., Tapping Screw and screwdriver used in mass production process.
- (4) No discoloration nor deformation should be caused by the heat of soldering.
- (5) In addition, both sides (mating side and solder side) of the contact and the housing must not be damaged or deformed by the operation. No crack, foreign substances are permissible in the mating area.

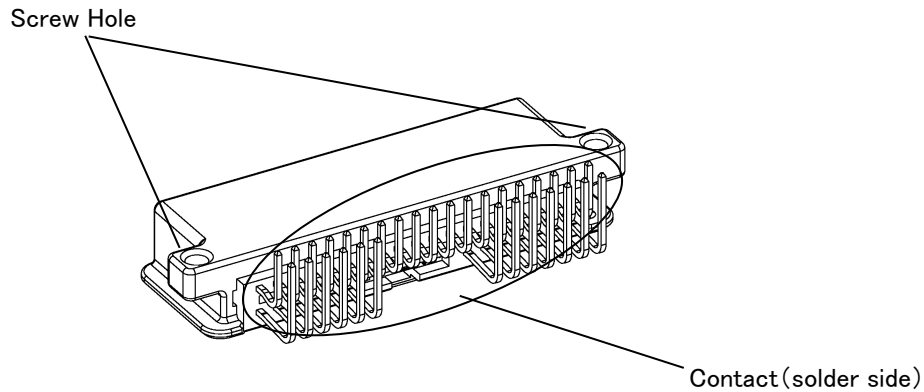

6. Mating and Extraction of Connector

6.1 Mating of Connector

- (1) Check to make sure that the contact is inserted into the housing in proper condition, the wire is taped up from proper position, and the retainer is in final lock condition. If the retainer is in pre-assembled condition, it must be changed to be in final lock condition.
- (2) And then check the contact and the housing into the male housing for defects, deformation, discoloration, damage, rust, crack, deficit, etc.

NOTE The connector must be renewed if any defects are found.

- (3) Insert the proper female housing into the male housing straight with same direction.

The operation is finished when you hear the click sound and can not insert further. When you can not insert the housing, do not insert by force, and check the items in (1), (2).

NOTE At the insertion operation, take care not to apply force except in the insertion direction.

By pulling the female connector lightly, check to make sure that the connector can not be withdrawn.

6.2 Extraction of Connector

Grip the female housing, and then draw straight out while pressing down the locking lever.

When the housing can not be drawn out, do not pull it by force but check to make sure if the locking mechanism is released.

NOTE At the extraction operation, take care not to apply force except in the extraction direction.

NOTE Do not pull the wire only.

6.3 General Attention Matters

- (1) Do not mate and extract the connector unnecessarily.
- (2) Do not insert any objects except the proper connector.
- (3) At mating /extraction operation, or after mating operation, take care not to apply unnecessary force or shock to the wire and the connector.