

1. Part Name and Part Number

1.1 Housing Case Cover

Part Number	Part Name
1473845-2	2Pos. Plug•Assembly A type
1473846-2	2Pos. Plug•Assembly B type
1473847-2	6Pos. Plug•Assembly
1747465-1	6Pos. Plug•Assembly (for CHFUS 0.35sq)
1473842-2	10Pos. Cap•Assembly
1565052-2	Case for 10Pos. Cap•Assembly
1565053-2	Cover for 10Pos. Cap•Assembly

Fig.1

1.2 Contact

Part Number	Part Name	Applicable Wire Size
1318329-1	Clean Body 025 Contact (Female Cont)	0.5mm ² Insulation Size φ 1.3 ~ 1.7 (mm)
1717148-1		CHFUS 0.35mm ² Insulation Size φ 1.1 ~ 1.2 (mm)

Fig.2

1.3 Structure of Product

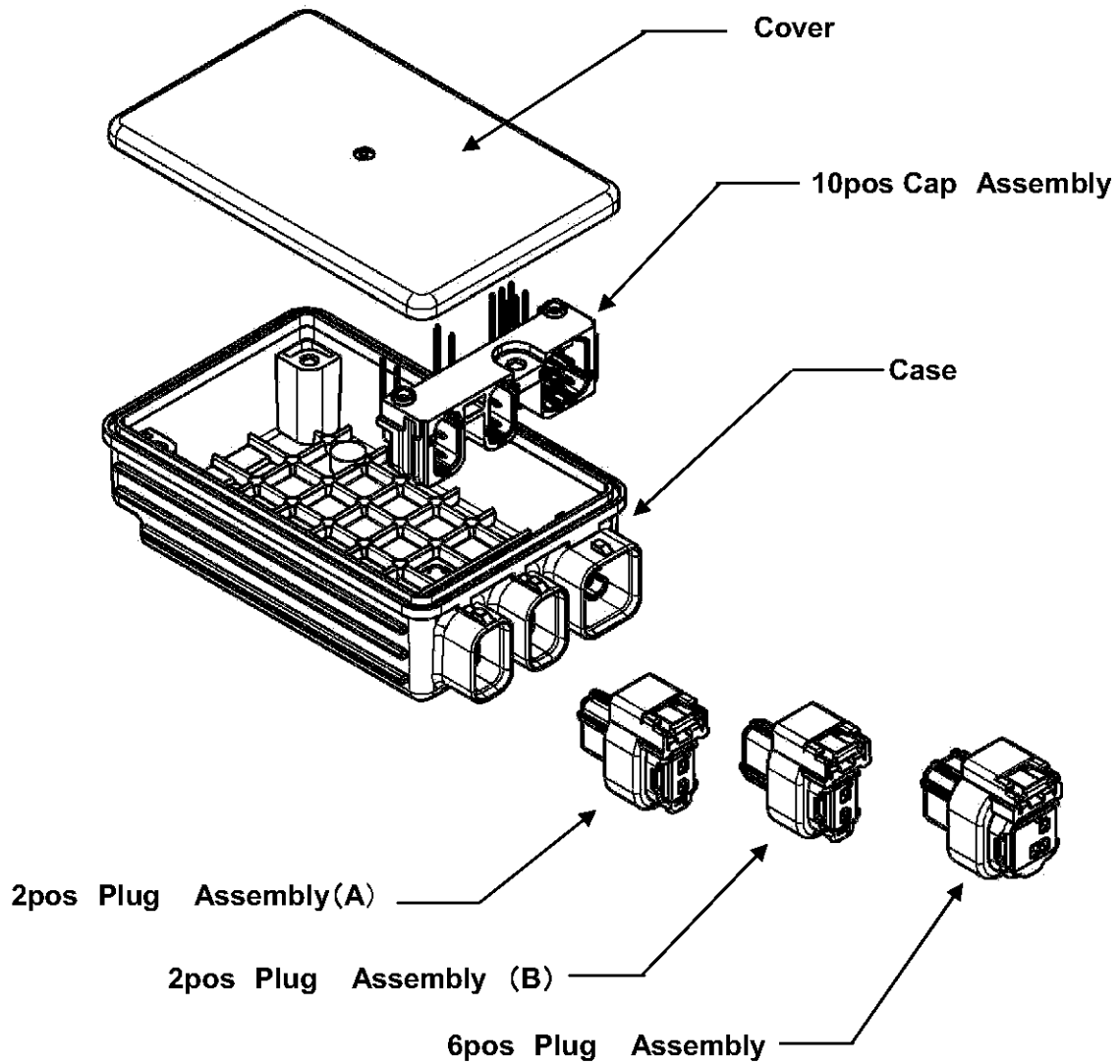

Fig.3

2. Customer Receiving Inspection

We conduct inspections accordance with our quality control regulations to maintain allover lot control. In addition, the customers should conduct receiving inspections based on the specific customer drawings.

3.Storage and Carrying

3.1 Contact

- (1) Avoid leaving or carrying the contact reel in open area without proper wrapping material.
- (2) Do not lift up carry the contact reel by gripping one side of the reel, this may result in damage to the reel and contacts before using. (See Fig.4)

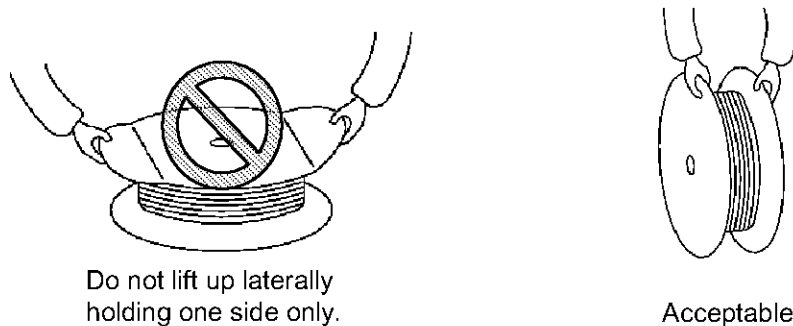

Fig.4

- (3) Avoid storing the contact reel in moist or dusty place. Stock the reel in a comparatively dry and clean place (5~35°C, 45~85%RH) away from direct sunlight.
- (4) When removing the contact reel from the machine, fasten the end of contact strip onto the edge of the reel with use of proper string or wire. (See Fig.5)

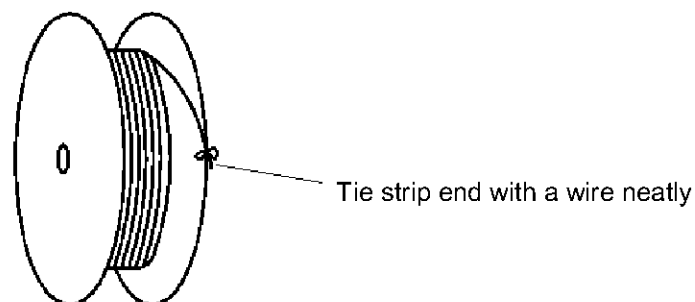

Fig.5

3.2 Housing

- (1) Avoid storing the contact reel in a moist or dusty place. Stock the reel in comparatively dry and clean place (5~35°C, 45~85%RH) away from direct sunlight.
- (2) Avoid leaving or carrying the contact reel in open area without wrapping it in proper material.
- (3) Do not drop or shock the housing when carrying it.

4. Crimping Operation

Any crimping of contacts must be performed by using appropriate AMP tools according to the applicable Instruction Sheet and Specification.

4.1 Wire

4.1.1 Applicable Wire

See Fig.2 for applicable wire.

4.1.2 Notes for Stripping of Wire End

Wire end must be stripped without nick, cutoff, or damage of wire strands.

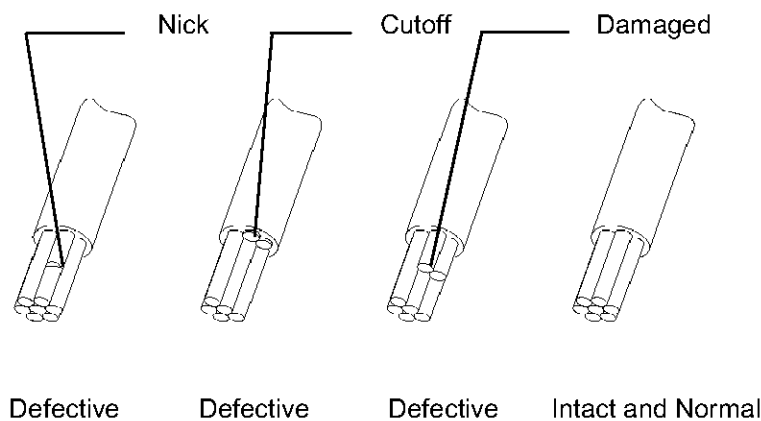

Fig.6

4.2 Crimping Specification

In the case of crimp, see application specification

Clean Body 025 Contact	114-5278
------------------------	----------

4.3 Storage and Handling of Crimped Products

- (1) Store the products in clean, dry area, cover with proper sheet or paper when placed in open area until the next day. Product storage without placing cover sheet when placed in open area for long time, should be forbidden always for prevention of contamination by dust and particles.
- (2) Care should be taken in case the leads catch together or be tangled, causing damage of the products.
- (3) Avoid stacking and piling up the in-process products in large volume. Deformation of the contact will result in malfunction of contacting parts electrically.
- (4) In order to arrange the tip of contacts, please do not strike the tip of contacts or do not hit against a hard flat place (desk etc). It makes mating or electrical defective.

5. Harness Making

5.1 Procedure for Female Terminal Insertion into Housing

- (1) Confirm the retainer is not put on the female housing. When the retainer is put on housing, it must be removed. See para.5.3. The terminal cannot be inserted in put it on housing.

Primary Lock Position

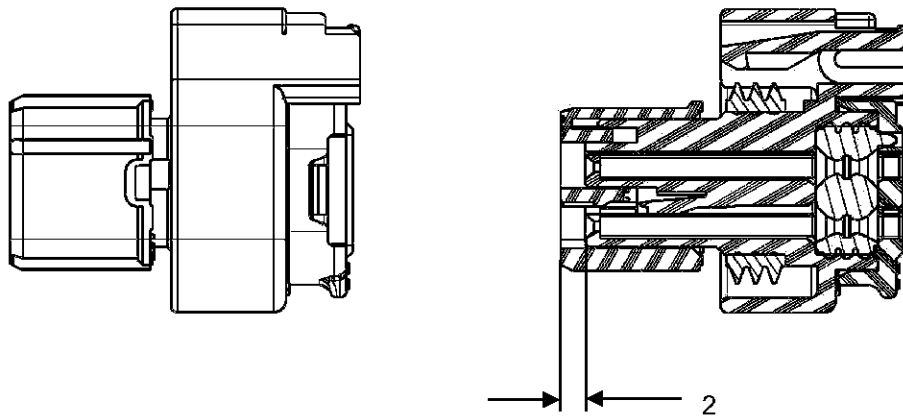

Secondary Lock Position

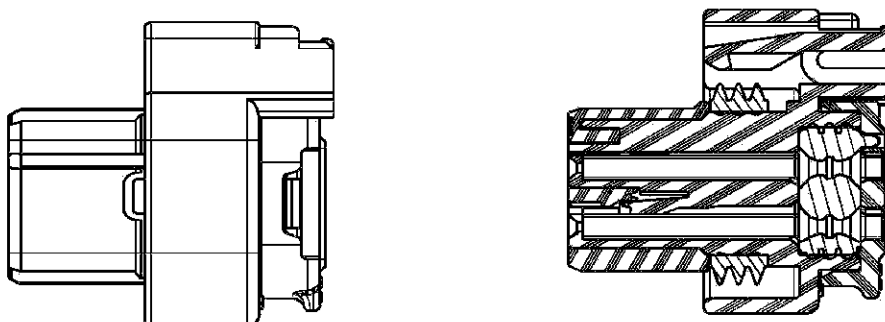

(2) Insert terminals into the housing with the direction as shown in Fig.8. The insertion is finished when the lance is locked and the terminal cannot be more inserted.

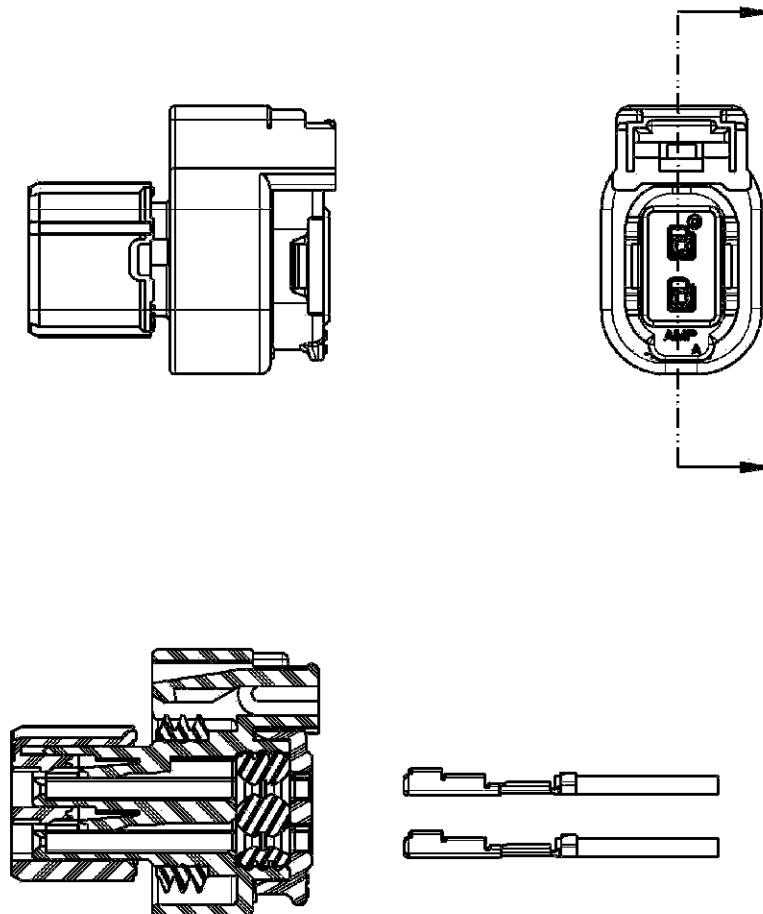

Clean Body 025 Contact

Fig.8

(3) By lightly pulling the contact (under 20N), check the terminal cannot be withdrawn.

Note Clean Body 025 Contact performs higher insertion force than non sealed type connector cause of using family seal devise. Clean Body 025 Contact especially requires careful insertion operation specified by above-mentioned (2) and (3).

5.2 Retainer Lock (Secondary Lock) Operation

- (1) After insertion of all of the terminals, put the retainer on the female housing. The double lock operation is finished by confirmation.

**Before Retainer Lock Operation
(Primary Lock Position)**

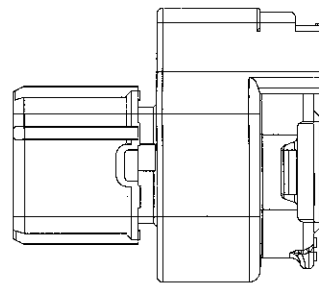
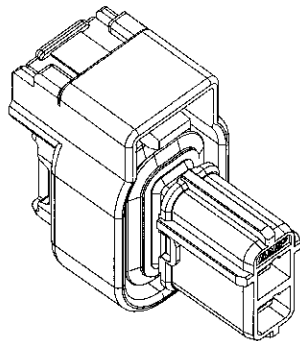

**After Retainer Lock Operation
(Secondary Lock Position)**

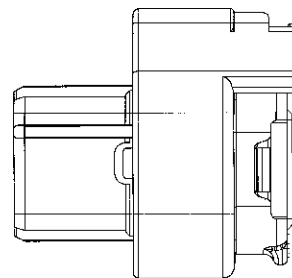
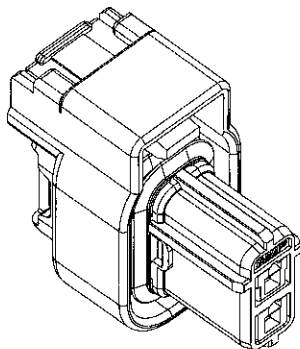

Fig.9

- (2) When the retainer can't be pushed into the female housing perfectly, please back to the primary lock position. And please confirm the half inserted terminals and try it again.

5.3 How to Unlock Retainer from Secondary Lock Condition

When the female terminal requires insertion, the retainer must be removed to "Primary Lock Position". And when the female terminal requires extension, the retainer must be removed perfectly. Insertion and extension working can't do at the "Secondary Lock Position".

- (1) Insert the precision screwdriver (1mm size) into the window of the retainer pointed.
- ※ 1) Put tip of the screwdriver on and release Secondary Lock on each side of retainer then move it to "Primary Lock Position". See Fig.10.
- (2) Draw out the retainer until the "Primary Lock Position" (about 2mm). And please confirm that all latches shall be "Primary Lock Position".

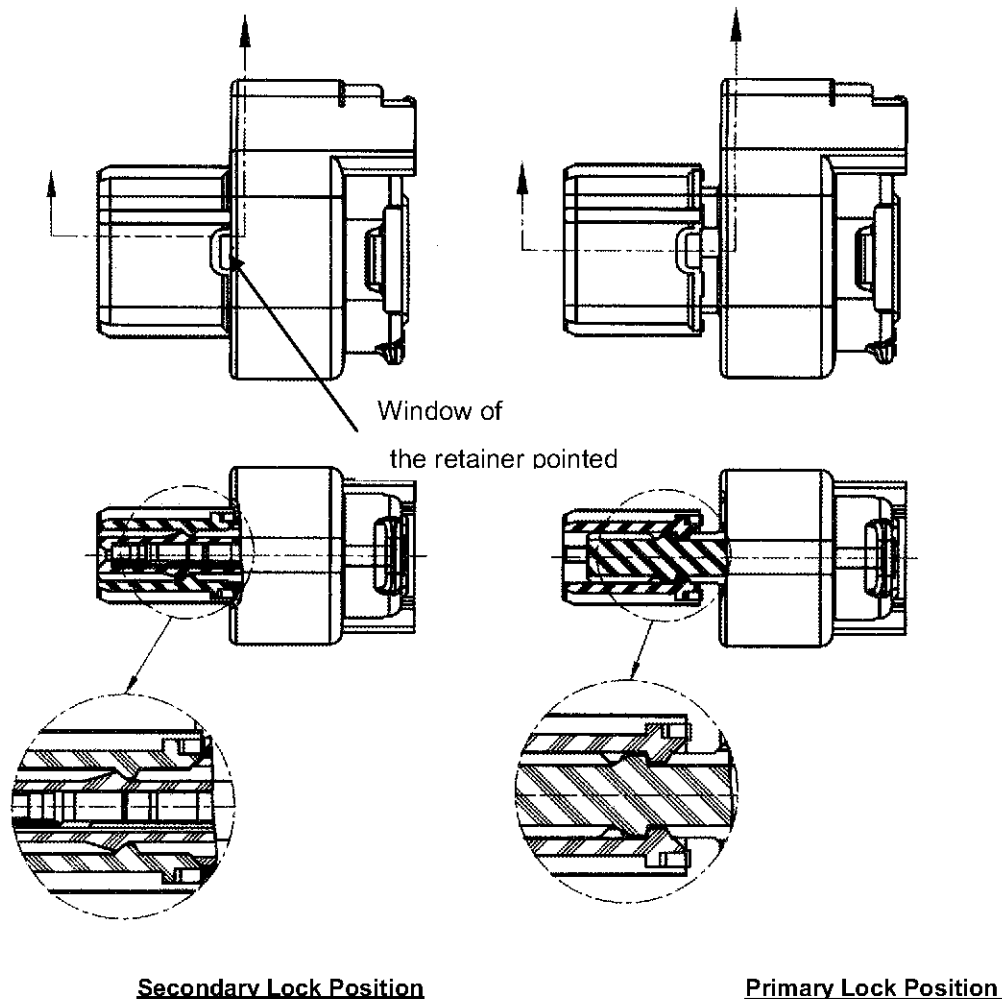

Fig.10

5.4 How to Extract Female Terminal

- (1) Confirm that the retainer is drawn out perfectly from female housing. If it is “Primary Lock Position” or “Secondary Lock Position”, draw out the retainer perfectly.
(Terminals can't be drawn out at “Primary and Secondary Lock Position”)
- (2) Extract contact with pulling the crimped wire while pressing latch slightly with 1mm blade screw.
(It makes easier the operation that push the terminals to bottom end of the cavities once before the operation above-mentioned.)

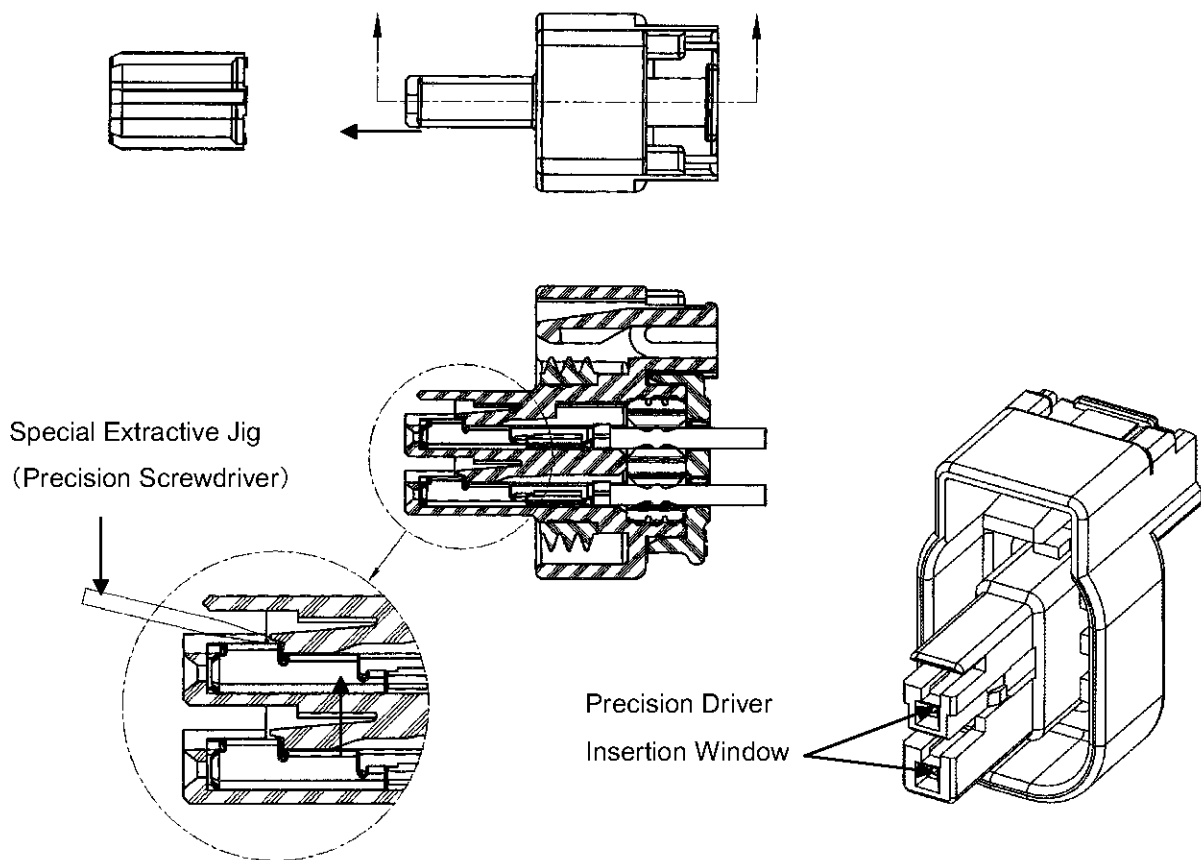

Fig. 11

- Note** Exchange the plug housing assembly without fail when the water sealing rubber is damaged by drawing out.
- Note** Limit of the female terminal wearing is 3 times. Exchange the plug housing assembly without fail when it is more than 3 times.
- Note** Take care not to insert the screwdriver or the extractive jig into the female contact. If those should be inserted, the female contact must be renewed. Re-using is never allowed

5.5 Harness Control

5.5.1 Handling

Take care not to apply unnecessary force or shock to the connector or the wire.

5.5.2 Bundling of Electronic Wires and Taping

Caution that position of tying wire should be separated more than 30mm from connector edge surface, and the strain power shouldn't be applied to Electronic Wires too much.

5.5.3 Electric Circuit Check

(1) Use applicable mating connector or equivalent for conductivity check jig.

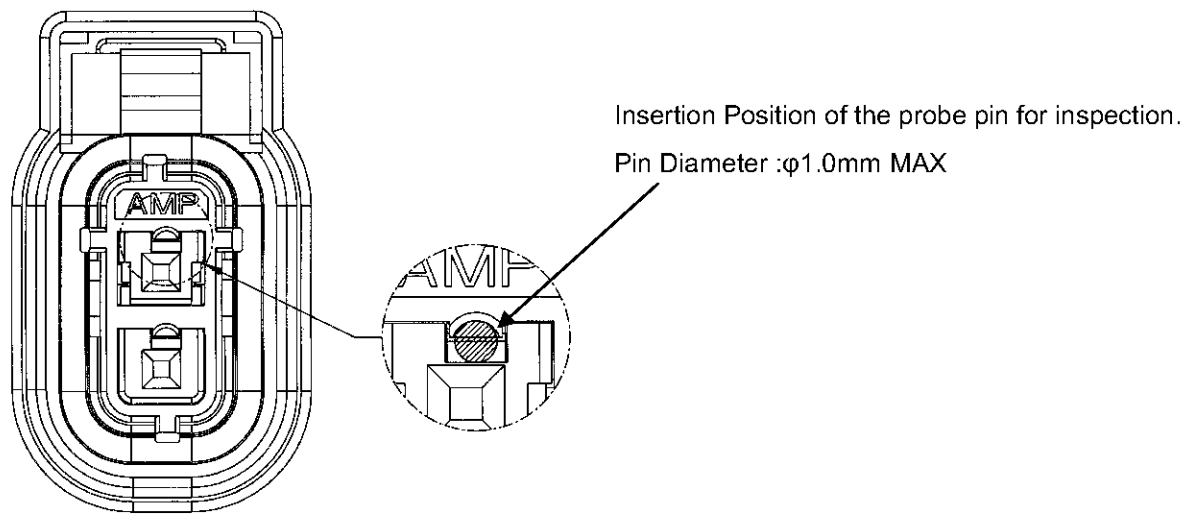

(2) Never insert the probe pin for the inspection into the female contact.

Note If the probe pin should be inserted, the female contact must be renewed.

(3) Please report to our company the treatment device for energizing inspection use.

5.5.4 Storage

Avoid storing the connector in a moist or dusty place. Stock the connector away from direct sunlight.

5.5.5 Shipping and Carrying

The connector should be used with the proper packaging to prevent the ingress of dust, moisture, etc.

6. Mating and Unmating of Connector

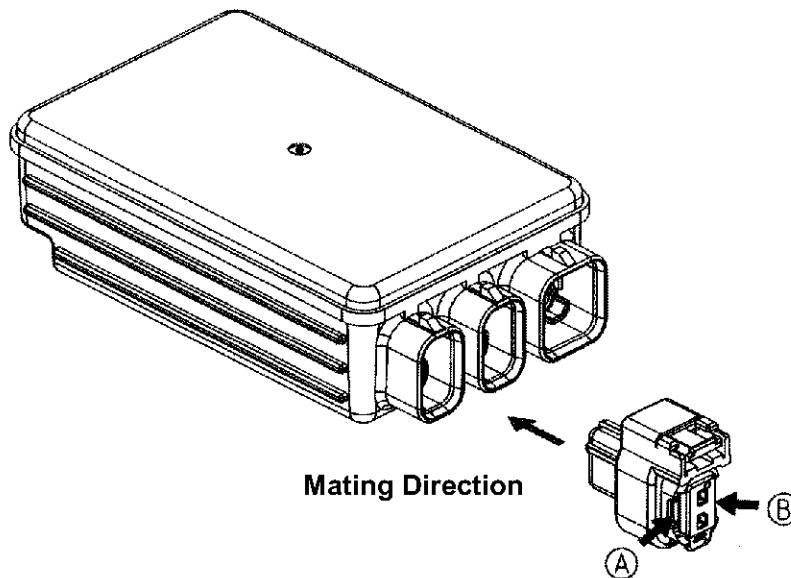

Fig.12

6.1 Mating of Connector

- (1) Check to make sure that the contact is inserted into the housing in proper condition, the wire is taped up from proper position, and the retainer is put on the female housing. If the retainer is not, it must be put on the housing. See para.5.3
- (2) And then check the contact and the housing into the male housing for defects, deformation, discoloration, damage, rust, crack, deficit, etc.

Note The connector must be renewed if any defects are found.

(3) Mate Connector

Put one's fingers to Section A and B and please push the plug housing into Mating Direction.

Note Mating 2pos Plug Assembly A, 2pos Plug Assembly B, and 6pos Plug Assembly to obtain the sealing performance.

6.2 Unmating of Connector

- (1) Insert a driver into the housing lock gap of Section C ,push down and release the lock leg.
- (2) Put one's fingers to Section D and draw out the connector from male connectors on this condition that push down the lock leg.

