

1. Parts Name and Parts Number (example)

1.1 Housing

- ① Plug (Female) Housing Assembly and Cap (Male) Housing Assembly for wire to wire Termination

Parts Name	AMP Parts Number	Parts Name	AMP Parts Number
16Pos. Plug (Female) Housing Assembly Type 1	1123371	16Pos. Cap (Male) Housing Assembly Type1	1123350
16Pos. Plug (Female) Housing Assembly Type 2	1123375	16Pos. Cap (Male) Housing Assembly Type2	1123353
16Pos. Plug (Female) Housing Assembly Type 3	1123377	16Pos. Cap (Male) Housing Assembly Type3	1123355
20Pos. Plug (Female) Housing Assembly Type 1	1123379	20Pos. Cap (Male) Housing Assembly Type1	1123357
20Pos. Plug (Female) Housing Assembly Type 2	1123383	20Pos. Cap (Male) Housing Assembly Type2	1123360
20Pos. Plug (Female) Housing Assembly Type 3	1123385	20Pos. Cap (Male) Housing Assembly Type3	1123362
24Pos. Plug (Female) Housing Assembly Type 1	1123387	24Pos. Cap (Male) Housing Assembly Type1	1123364
24Pos. Plug (Female) Housing Assembly Type 2	1123391	24Pos. Cap (Male) Housing Assembly Type2	1123367
24Pos. Plug (Female) Housing Assembly Type 3	1123393	24Pos. Cap (Male) Housing Assembly Type3	1123369

Type1,2,3 : Cording Type

② Cap (Male) Assembly for I/O (P.C.Board)

Parts Name	AMP Parts Number	Parts Name	AMP Parts Number
3Pos. Cap (Male) Assembly Type1 (※1)	1123476	16Pos. Cap (Male) Assembly Type1	1123419
3Pos. Cap (Male) Assembly Type2 (※1)	1123478	16Pos. Cap (Male) Assembly Type2	1123421
4Pos. Cap (Male) Assembly Type1 (※1)	1123395	16Pos. Cap (Male) Assembly Type3	1123423
4Pos. Cap (Male) Assembly Type2 (※1)	1123397	16Pos. Cap (Male) Assembly V-Type	1318229
6Pos. Cap (Male) Assembly Type1 (※1)	1123619	20Pos. Cap (Male) Assembly Type1	1123425
6Pos. Cap (Male) Assembly Type2 (※1)	1123621	20Pos. Cap (Male) Assembly Type2	1123427
8Pos. Cap (Male) Assembly Type1 (※1)	1123451	20Pos. Cap (Male) Assembly Type3	1123429
8Pos. Cap (Male) Assembly Type2 (※1)	1123453	20Pos. Cap (Male) Assembly V-Type	1376310
8Pos. Cap (Male) Assembly V-Type (※1)	1376464	24Pos. Cap (Male) Assembly Type1	1123431
10Pos. Cap (Male) Assembly Type1 (※1)	1123407	24Pos. Cap (Male) Assembly Type2	1123433
10Pos. Cap (Male) Assembly Type2 (※1)	1123409	24Pos. Cap (Male) Assembly Type3	1123435
10Pos. Cap (Male) Assembly Type3 (※1)	1123411	24Pos. Cap (Male) Assembly V-Type	1123983
12Pos. Cap (Male) Assembly Type1 (※1)	1123413		
12Pos. Cap (Male) Assembly Type2 (※1)	1123415		
12Pos. Cap (Male) Assembly Type3 (※1)	1123417		
12Pos. Cap (Male) Assembly V-Type (※1)	1376465		

Type1,2,3 : Cording Type

※1 : Applicable Mating Connector made by YAZAKI PARTS CO.,LTD.

1.2 Contact

① Receptacle Contact

Parts Name	AMP Parts Number	Applicable Wire(mm ²)			
		Type	0.3	0.5	0.85
040III Rec.	Sn 316836-1 Au 316837-2	CAVUS	○	○	○
		CAVS/ AVSS	○	○	×
		AVS	○	×	×
	Sn 1123653-1 (MS)	CAVUS	×	×	○
		CAVS/ AVSS	×	×	○

② Tab Contact

Parts Name	AMP Parts Number	Applicable Wire(mm ²)			
		Type	0.3	0.5	0.85
040III Tab.	Sn 353537-1 Au 353537-2	CAVUS	○	○	×
		CAVS/AVSS	○	○	×

○ : Applicable × : NOT Applicable

Application Specification.....114-5217「Crimping 040III Unsealed Contact Receptacle」

114-5228「Crimping 040III Unsealed Contact Tab」

Extraction Tool Jig...CKZ Jig (Jig feature :See fig.1)

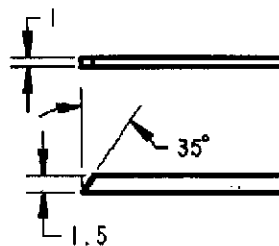

Fig. 1

2.Components View

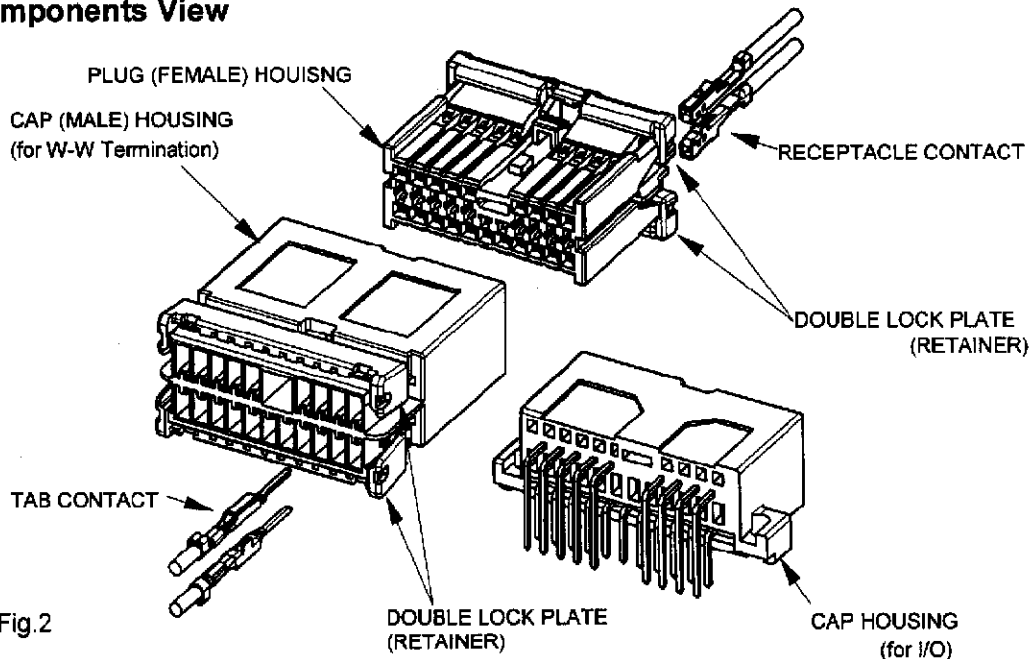
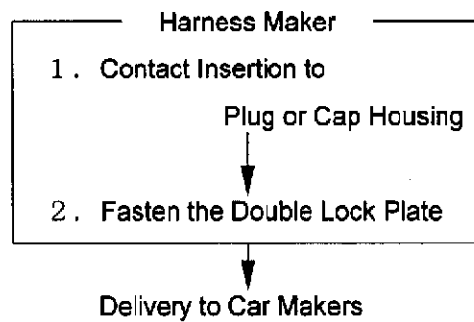

Fig. 2

3. Harness Making



3.1 Contact Insertion into Housing Assembly

The contact insertion should always be made under the pre-lock condition of the retainer.

(1) Check the direction of contact and insert the contact fully into the cavity in the direction of axis till a clicking sound can be heard. Take care not to push the contact by force.

(2) Direction of contact Insertion

Direction of contact can be checked the position of stabilizer. See fig 3,4

Contact Insert into upper side cavity and lower side cavity is upside down.

Cap housing assembly

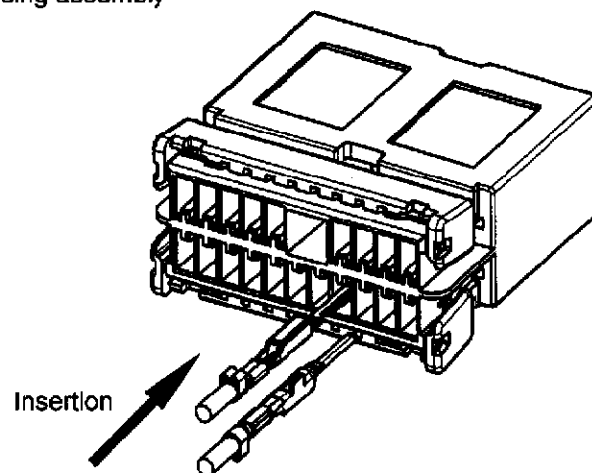

Direct the contact stabilizer toward the housing partition.

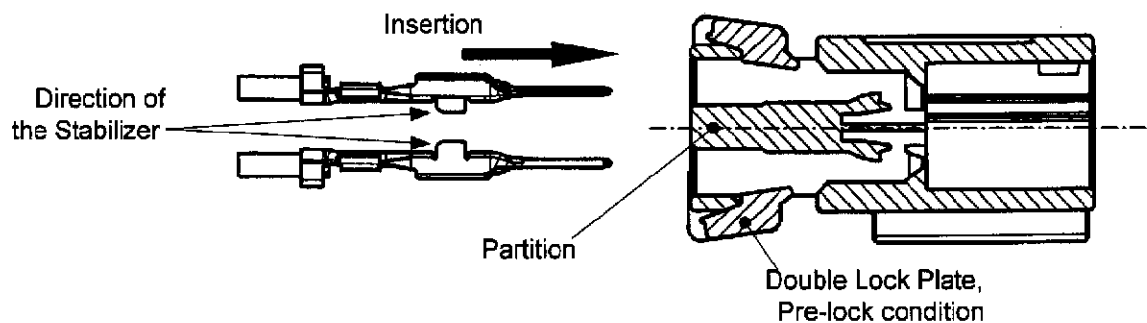
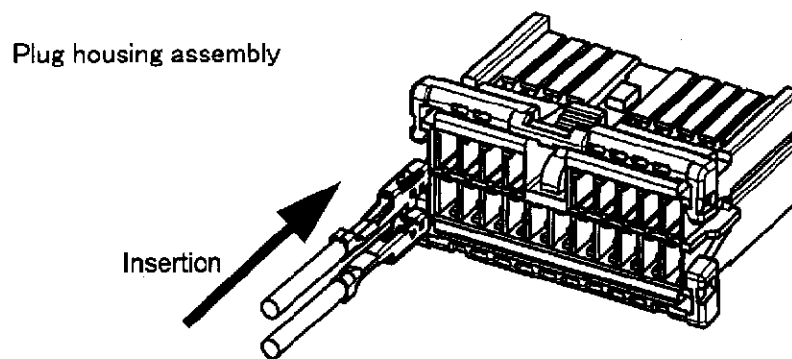

Fig. 3



Direct the contact stabilizer toward the housing partition.

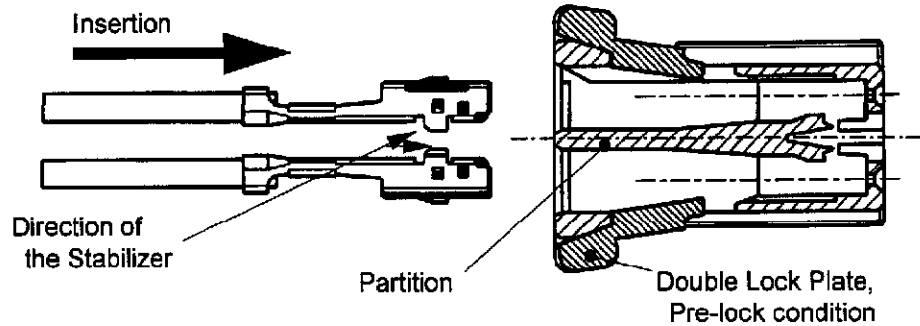

Fig.4

3.2 Double Lock Plate (Retainer) Fastening to Final locking

(1) Fully fasten the Double Lock Plate to final locking from the pre-lock condition completely, after all contacts are inserted. Fasten the Double Lock Plate like pushing contacts. See Fig.5,6.

(2) Check which the surfaces of Double Lock Plate and housing are same height.

CAUTION

If surfaces of the both are not aligned, the Double Lock Plate cannot be fastened fully. Don't push the contact into the cavity by force.

Cap Housing Assembly

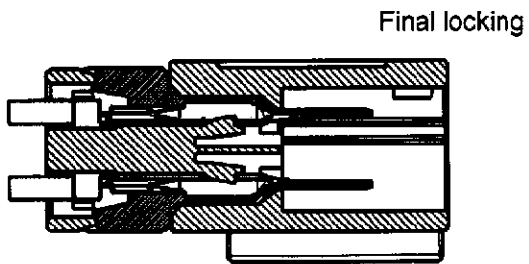
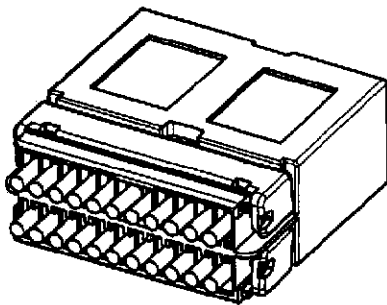
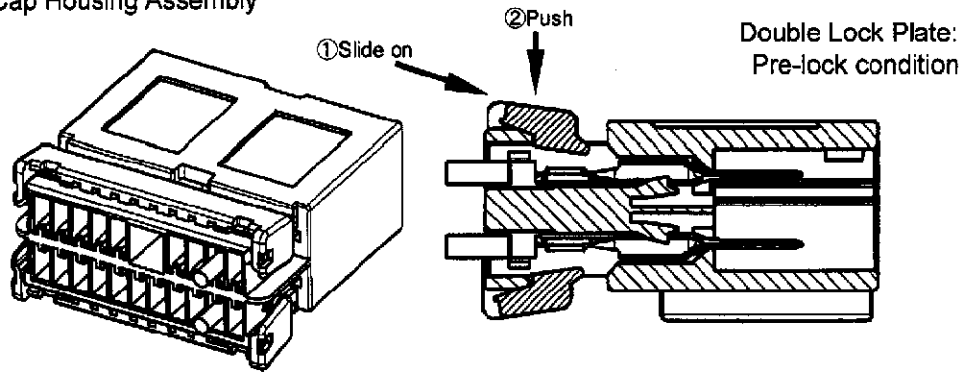

Fig. 5

Plug Housing Assembly

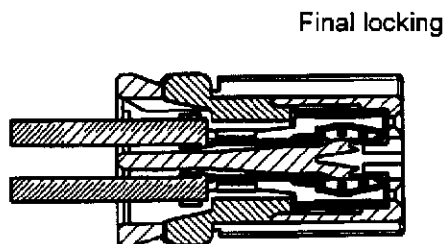
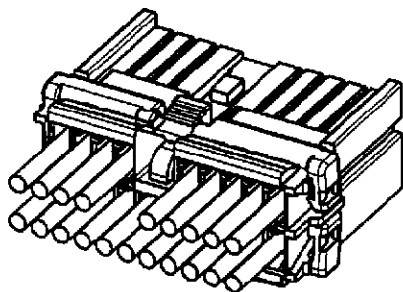
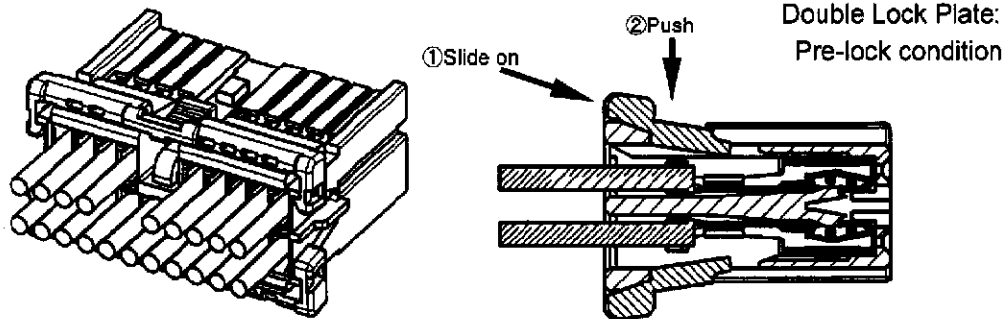
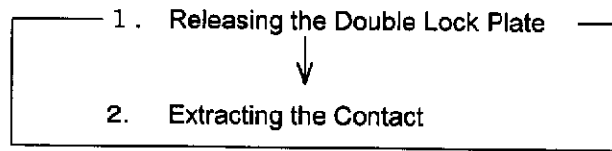

Fig. 6

4. Contact Extraction



4.1 Releasing the Double Lock Plate (Final locking → Pre-lock condition)

(1) In disengage the Double Lock Plate, use the jig "CKZ : see Fig.1" or driver, etc.. Raise the Double Lock Plate from Final locking in the direction of the arrow (see fig.7,8).

(2) Pull (slide on) the Double Lock Plate to Pre-lock condition in the direction of the arrow (see fig.7,8,9).

Cap Housing Assembly

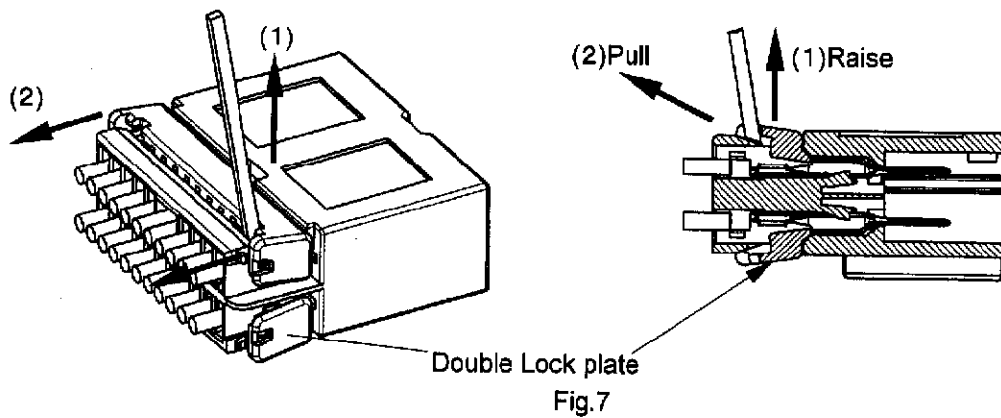

Plug Housing Assembly

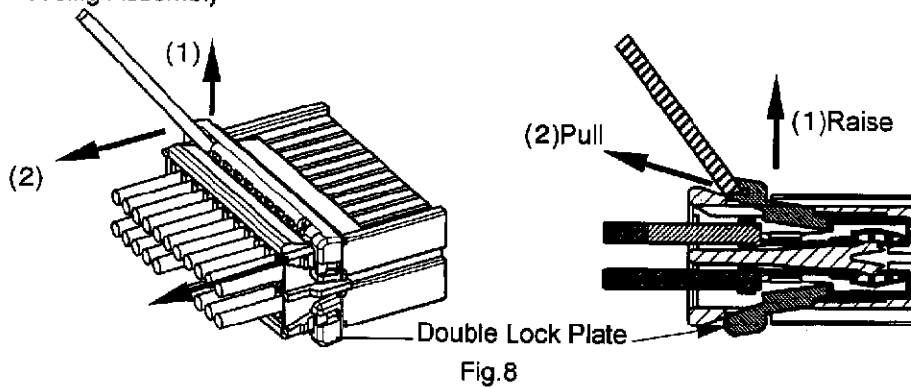

Cap Housing Assembly

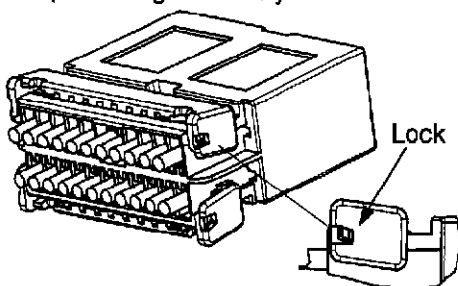

Plug Housing Assembly

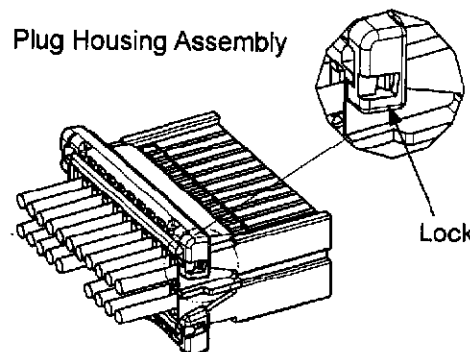

Fig.9 Pre-lock condition (Locking Position)

4.2 Extracting the Contact

After releasing the Double Lock Plate, extract the Contact, and use the jig "CKZ".

First, push the contact lightly. And insert the jig into the proper hole in the direction of axis, remove the contact from the housing. See fig.10,11.

Cap Housing Assembly

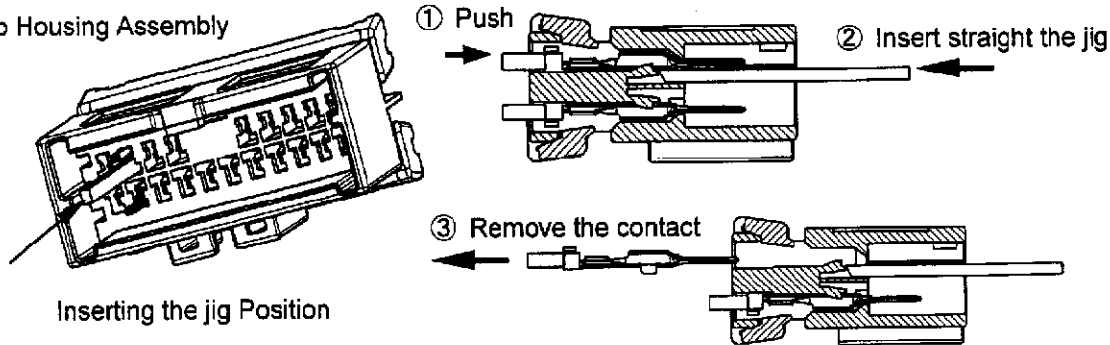

Fig.10

Plug Housing Assembly

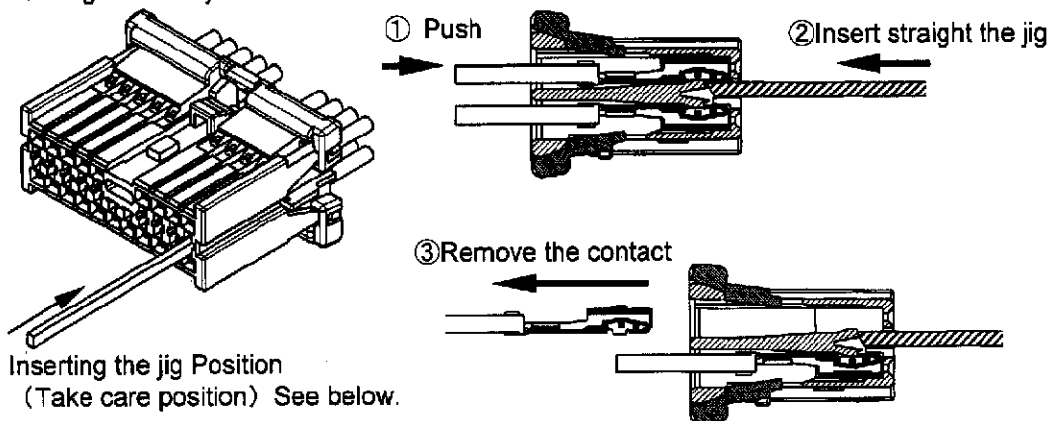
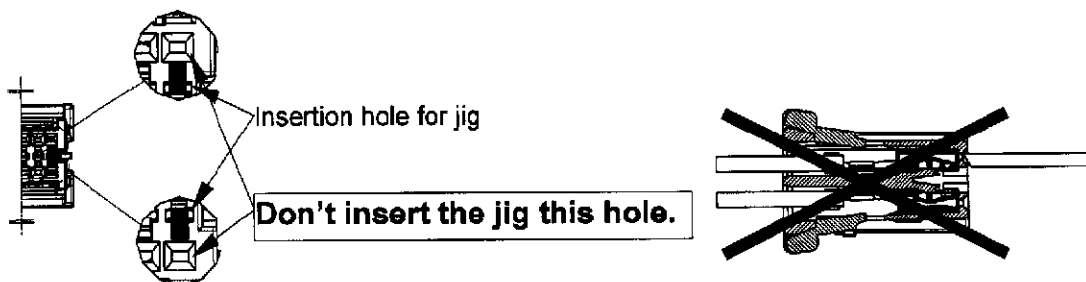

Fig. 11



CAUTION

- Don't insert the jig or the screwdriver into the receptacle contact. If those should be inserted, the receptacle contact must be renewed.
- Take care not to make the contact or housing transform, the contact or housing must be renewed. Re-using is never allowed.

4.3 Harness Control

(1) Handling

Take care not to apply unnecessary force or shock to the connector or the wire.

(2) Taping up Wires

The wires must not be taped up more than 30mm from the end of the housing to avoid applying unnecessary force to the wires. See Fig.12.

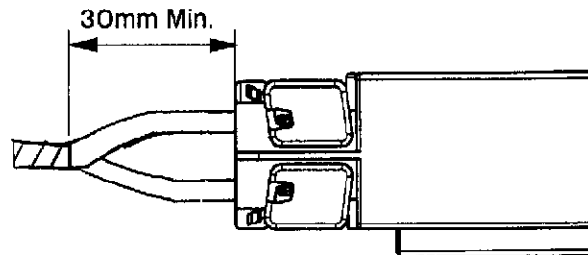

Fig.12

(3) Storage

Avoid storing the connector in a moist or dusty place. Stock the connector away from direct sunlight.

(4) Shipping and carrying

The connector should be used with the proper packaging to prevent the ingress of dust, moisture, etc.

5.Mating and Extraction of Connector

5.1Mating of Connector

(1) Check to make sure that the contact is inserted into the housing in proper condition, the wire is taped up from proper position, and the Double Lock Plate is in fully fastened position. If the Double Lock Plate is in Temporarily fastened position., it must be changed to be in fully fastened position. See para.3.

(2) And then check the contact and the housing into the housing for defects, deformation, discoloration, damage, rust, crack, deficit, etc.

CAUTION: The connector must be renewed if any defects are found.

Insert the proper plug housing into the cap housing or cap assembly straight with same direction as shown in Fig.13. The operation is finished when you hear the click sound and can not insert further. When you can not insert the housing, do not insert by force, and check the items in (1),(2).

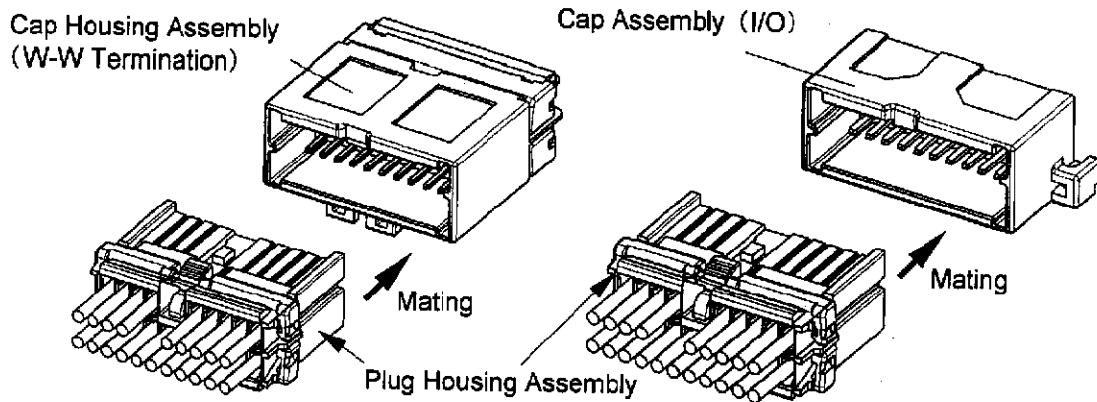

Fig.13

(4) By pulling the plug housing assembly lightly, check to make sure that the connector can not be with drawn.

5.2 Extraction of Connector

Grip the plug housing assembly, and then draw straight out while pressing down the locking lever perfectly.

When the housing can not be drawn out, do not pull it by force but check to make sure if the locking mechanism is released.

CAUTION

- Perform the connector insertion and extraction straightly without giving "KOJIRI" motions.
- Do not pull the wire only .

5.3 General Attention Matters

- (1) Do not mate and extract the connector unnecessarily.
- (2) Do not insert any objects except the proper connector.
- (3) At mating/extraction operation, or after mating operation, take cares not to apply unnecessary force or shock to the wire and the connector.