

**AMP ECONOSEAL-J MARK II +  
SENSOR CONNECTOR****INSTRUCTION SHEET**

(This instruction sheet may change without notice.)

1. General Description:

AMP-ECONOSEAL-J MARK II+ Connectors are an improved version of AMP-ECONOSEAL-J Sensor Connectors, having features based on double locking device, details of which are described as follows:

- (1) Incomplete positioning of mounting in housing can be detected manually and visually.
- (2) Conventional receptacle contacts are used for this application.
- (3) MARK II+ version connectors are enabled for interchangeable use with the conventional type connector. (MARK II+ version ones can be mated with the conventional type connectors.)
- (4) Outer featuring dimensions are typical with those of conventional ones.

Applicable Product Part Numbers:

Product Descriptions	Conventional	Double Lock	Remarks
	Type Conn. AMP P/N	Type Conn. AMP P/N	
1-Pos. Plug Connector (A) For TZS17 <sup>o</sup>	174371	—	
2-Pos. Plug Connector (B) For TZS22 <sup>o</sup>	174372	178390	
2-Pos. Plug Connector (B) For TZS22 <sup>o</sup>	176321	178448	w/Silicon Seal Ring
2-Pos. Plug Connector (C) For TZS35 <sup>o</sup>	174373	—	
2-Pos. Plug Connector (D) For Cooling Water Temperature Sensor	174374	178392	
2-Pos. Plug Connector (D) For Cooling Water Temperature Sensor	176322	178449	w/Silicon Seal Ring
4-Pos. Plug Connector (A) For Throttle Valve Sensor	174382	178399	
4-Pos. Plug Connector (B) For Throttle Valve Sensor	175723	178398	

2. Harness Assembly Operation:

2.1 Loading the Crimped Contact into Housing Cavity:

The double lock plate of this housing is in preparatory locking position as the housing is supplied to the customer. For loading contact into housing, proceed as follows:

- (a) Before loading contact, make sure that the double lock plate is in preparatory position before full engagement, and insert the contact into housing cavity with its orientation rightly applied into the cavity as far as it bottoms in the housing cavity. See Para. 2.3 for full engagement of double lock plate.

In Preparatory Position

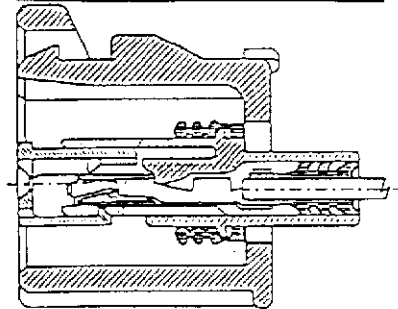

Full Engagement Position:

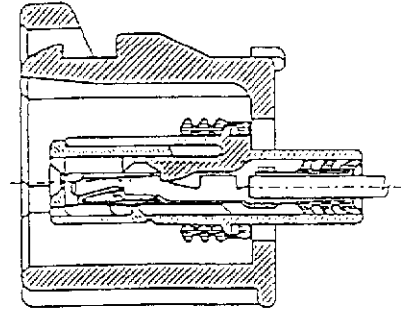

- (b) When the double lock plate is in full engagement position, the contact cannot be inserted into housing cavity. With this double lock plate position, never try to insert contact forcibly, lest it should result deformation of contact or damage of housing.
- (c) When the double lock plate is in full engagement position, refer to Para. 2.4, and unlock the double lock plate to make it in preparatory locking position, and try loading the contact according to Para. 2.1.

2.2 Insertion of Cavity Plug into Housing:

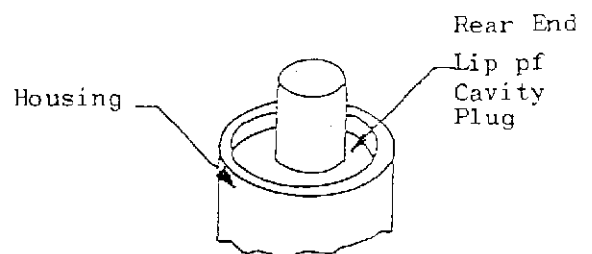
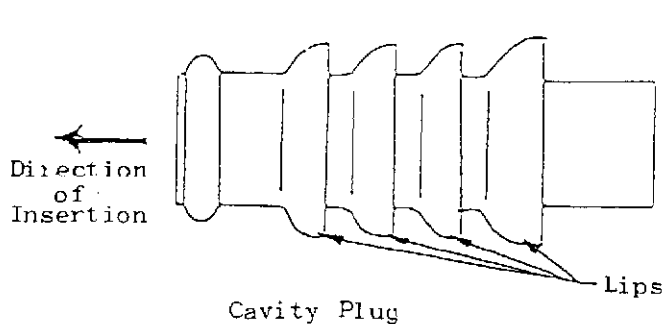

Lips of the cavity plug must be fully fitted in housing cavity bottoming in the depth.

2.3 Full Engagement of Double Lock Plate:

As all the contact positions are fully loaded with the terminated contacts, the connector is, now, ready for full engagement setting of double lock plate.

- (a) Press the double lock plate in housing uniformly by hands as shown in Fig. 2.

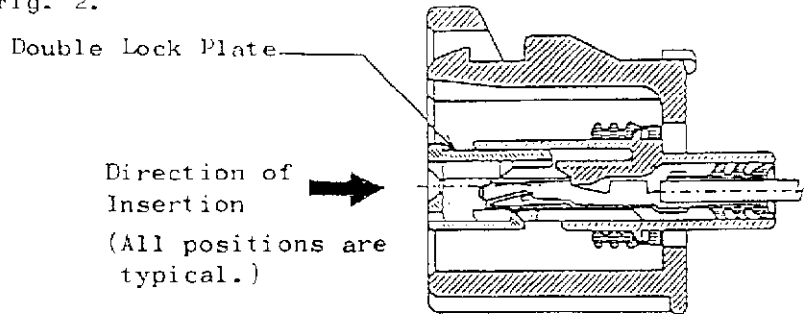

Fig. 2

- (b) When the double lock plate is fully engaged, a clicking sound is heard.
- (c) When the double lock plate does not engage fully, in spite of pressing it by 3 - 4 kg load, do not attempt to keep forcing as it is. Check to see if the contacts are loaded in contact cavities normally. After confirming the contact condition, try it again mederately.

2.4 Disengagement of Double Lock Plate:

(How to return to the condition of preparatory engagement)

When you need to disengage the double lock plate, as you find erroneous application of contact after engagement of double lock plate, or the double lock plate is already engaged before loading of contacts or as such, unlock the double lock plate, and make it returned to the condition before engagement, by the following procedure. (With the double lock plate fully engaged, contact loading cannot be performed.)

Proceed as follows:

Insert tip end of a 1.0mm wide, watchmakers precision screw driver into a slit between the  $\nabla$ -marked portion of double lock plate and housing wall, and dig up the double lock plate until it is unlocked.

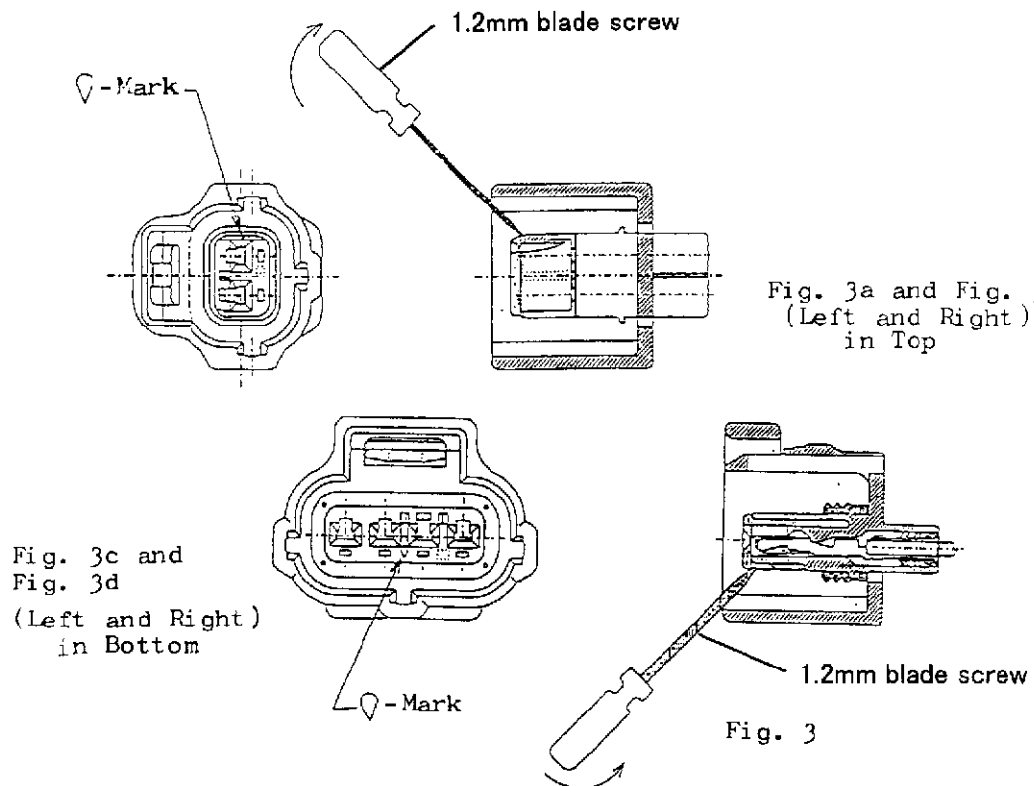

Fig. 3a and Fig. 3b  
(Left and Right)  
in Top

Fig. 3c and  
Fig. 3d  
(Left and Right)  
in Bottom

Fig. 3

2.5 Extraction (Unloading) of Contact:

- (a) Following to the procedure described in Para. 2.4, return the locking status of the double lock plate to the condition of preparatory engagement.
- (b) Hold the wire of the contact you are to remove in fingers, and press it in so as to bottom the contact in the cavity, and holding it as it is.
- (c) Insert watchmaker's screw driver between the tip end of housing lance and contact as shown in Fig. 4, and dig the lance up.
- (d) Pull back the contact wire, and the contact is pulled out.

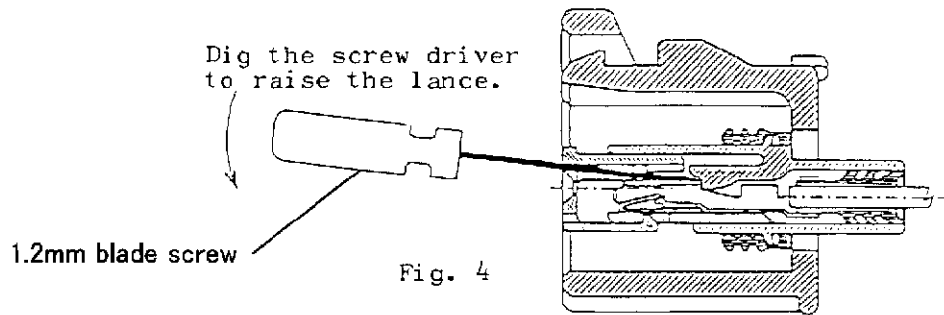

Notice:

During the contact removal operation, never insert tip end of the screw driver into the contacting area of receptacle contact. See Fig. 5.

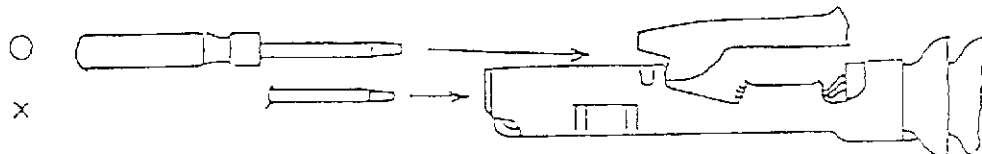

3. Contact Replacement in Harness Assembly Operation:

During harness assembly operation, replace the contact when you find it is necessary to remove defective contact, and replace it with the new one, follow the procedure as stated below:

- (1) Cut off the defective contact by the wire next to it.
- (2) Strip the wire insulation to the length of 4 - 4.5mm.
- (3) Apply a rubber plug to the wire in the direction as so designated, and slide it to the position accordingly.

Rubber plug is inserted into housing cavity, by using the appropriate insertion tool. Select the tool by Fig. 6.

	Simplified Insertion Fixture		Insertion Fixture
	For O70 Series (0.2/0.5mm <sup>2</sup> Wire) Application	For O70 Series (0.5/1.25mm <sup>2</sup> Wire) Application	For .070 Series Contact Application
Fixture Part No.	753838-1	753838-3	753812-2
Identification Sketches			

Fig. 6

(3) - (1) How to Use Simplified Insertion Fixture:

Put the fixture into the rubber plug, and push it through the rubber plug as shown below.

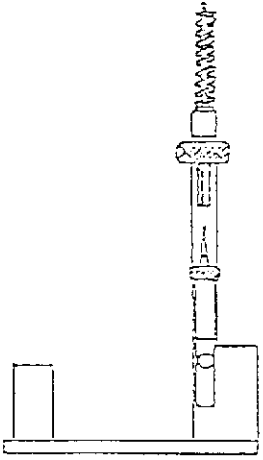
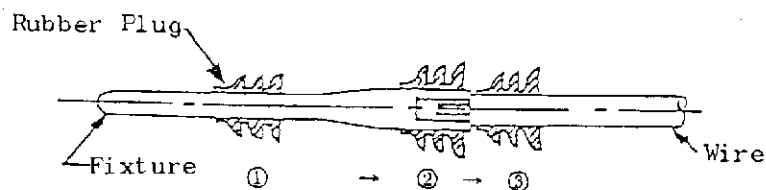
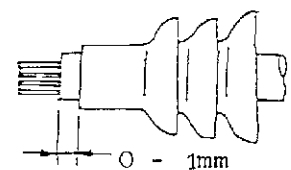

Fig. 7a

By holding the fixture, insert the rubber plug moderately into the housing cavity to bottom it fully in the depth.



Wire End Protrusion Length Fig. 7b

Do not tilt the rubber plug when fitted in housing.

(3) - (2) How to Use Insertion Fixture:

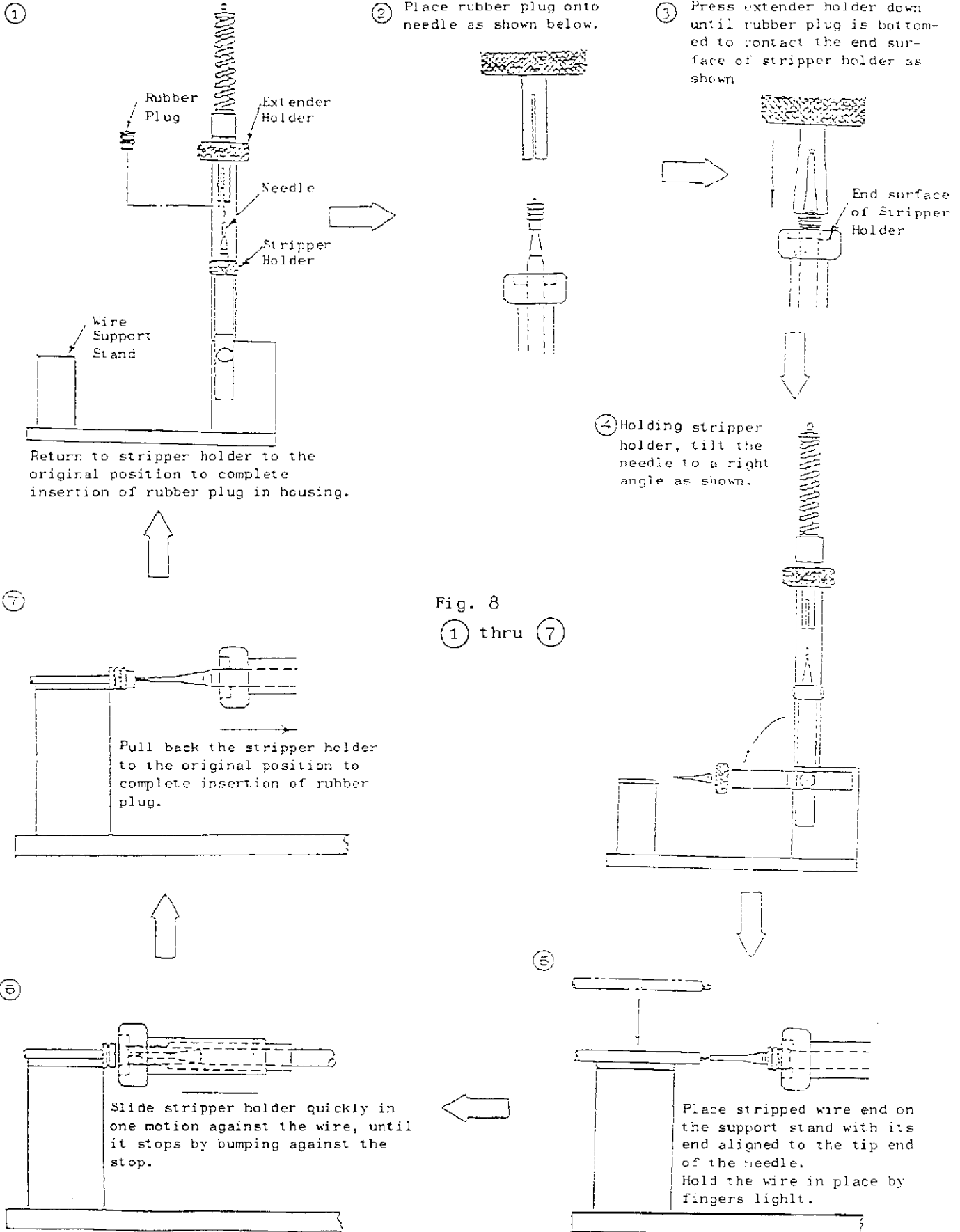

(4) Crimping:

The end of wire insulation must remain intact as it was at crimping, or must be in condition that enables visual checking by pulling up the rubber plug.

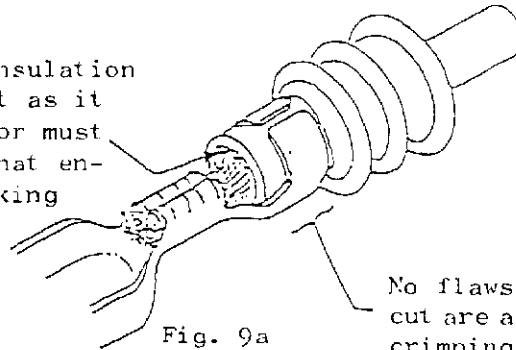

No flaws, damage and cut are allowed after crimping.

Fig. 9a

Protrusion of rubber plug must be 0.5mm minimum.

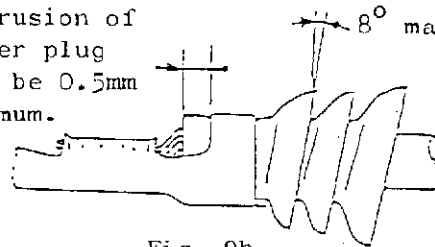

Tilt of rubber plug is permissible within 8° max.

Fig. 9b

When deformation of contact is found after crimping, check it according to applicable Application Specification, 114-5082. Rework contact when reusable by reforming accordingly. For detailed acceptance limits, refer to 114-5082.

(5) Automatic Contact Assembly Machine:

For automated assembly processing of O70 Series contact, including wire stripping, applying rubber plug onto the wire, and wire crimping, SCAT (Sealed Contact Automatic Terminator) Machine is available to facilitate operation. For detailed descriptions, refer to CM-234J.