

Rectangular Connector Variant 14 PushPull Frame IP65/67

1.Scope / Anwendungsbereich

This Instruction Sheet describes the assembly procedure of the Variant 14 PushPull Frame in combination with Receptacle for Fiber Optic.

Diese Installationsanleitung beschreibt die Montage des Rahmens für Variante 14 PushPull in Kombination mit der Buchse für Fiber Optic.

2.Description of the single parts / Beschreibung der Einzelteile

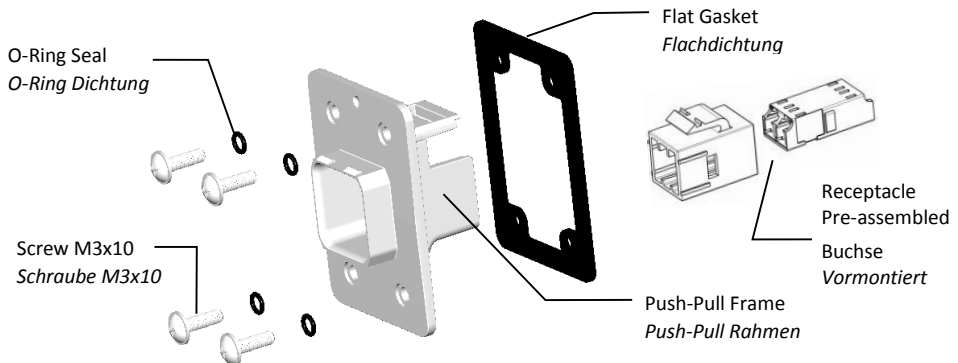

Attention: Components may vary with Images by application!

Hinweis: Komponenten können von den Abbildungen variieren!

3.Technical data / Technische Daten

Degree of protection / Schutzarten:	IP 65/67
Operating temperature / Betriebstemperatur:	-40°C ...+70°C
Dimensions (l,w,h) / Abmessung ca. (L,B,H):	64.3mm, 22.8mm, 28.9mm

All specifications subject to change. Consult TE Connectivity for latest specifications.

©2014 Tyco Electronics Corporation, a TE Connectivity Ltd.
Company
All Rights Reserved
| Indicates Change

This controlled document is subject to change. For latest revision and Regional Customer Service, visit our website at www.te.com
PRODUCT INFORMATION 1-800-522-6752

1 von 4
ECOC EGD0
LOC AI

*Trademark. TE Connectivity, TE connectivity (logo), and TE (logo) are trademarks.
Other logos, product and/or Company names may be trademarks of their respective owners.

Rectangular Connector Variant 14 PushPull Frame IP65/67

4. Suitable field installable Fiber Optic Receptacles- Pre-assembled

Passende feldkonfektionierbare Fiber Optic Buchsen- Vormontiert

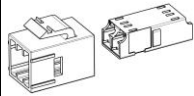
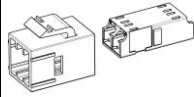
Part Number	Description / Beschreibung	
2120870-1 6693648-2	Variant 14 PushPull Fiber Optic, LC / Single Mode (blue)	
2120870-1 6693648-1	Variant 14 PushPull Fiber Optic, LC / Multi Mode (beige)	

5. Assembly Procedure / Montageanleitung

5.1. Preparing / Vorbereitung

Cut out Measurement (mm) / Ausschnitt Maße (mm)

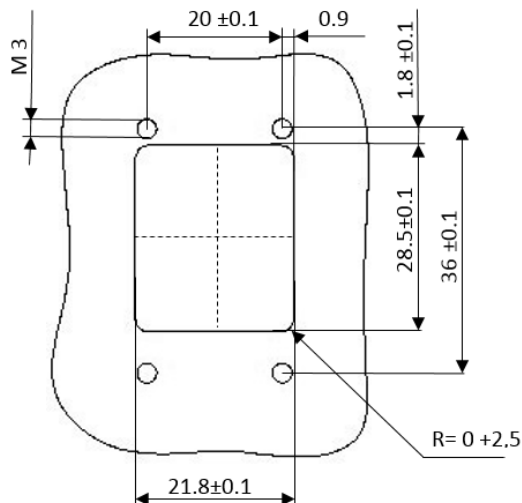

Rectangular Connector Variant 14 PushPull Frame IP65/67

5.2. Attaching the seal/ Montieren der Dichtung

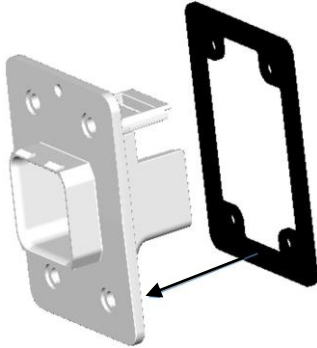

- Place the flat gasket into the corresponding with the cut out
- Legen Sie die Flachdichtung in die entsprechende Aussparung

5.3. Receptacle lock/ Buchse einrasten

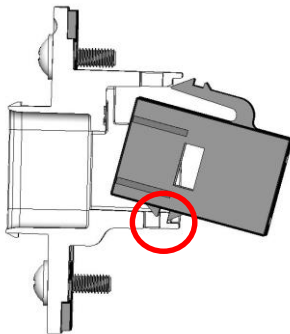

Fit the Receptacle into the tongue of frame on bottom groove

Untere Führungsnut der Buchse auf den Steg des Rahmens aufsetzen

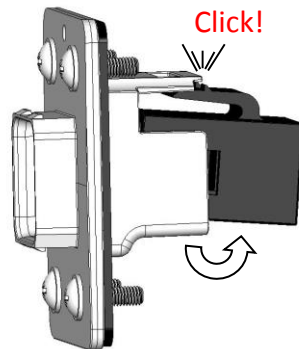

Upper groove of Receptacle should swing into the frame until it "clicks"

Obere Führungsnut der Buchse in den Rahmen einschwenken, bis er mit einem hörbaren „Klick“ eingerastet ist

Rectangular Connector Variant 14 PushPull Frame IP65/67

5.4. Attachment of PushPull frame / Befestigen des PushPull Rahmens

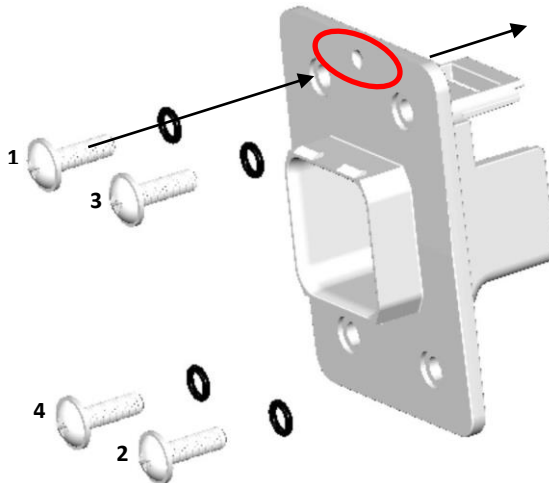

Set the frame into the cut out. Insert the screw with O-Ring seal and screw it into the frame in a cross sequence

Gehäuse in den Ausschnitt einsetzen. Schrauben mit O-Ring-Dichtung versehen und durch den Rahmen über Kreuz festschrauben



Attention: Please make sure that the mark dot is at the top!

Hinweis: Stellen Sie sicher, dass der Markierungspunkt oben ist!

Tightening torque: 0.4Nm !

Anzugsdrehmoment: 0.4Nm !