



# PRINTHEAD SETUP AND REPLACEMENT FOR T3212 & T3224 PRINTERS

THIS IS A CLASS 1 DOCUMENT WHICH IS NONCONFIDENTIAL.

*The information contained within this document is the property of TE Connectivity. It is supplied in confidence and the commercial security of the contents must be maintained. It must not be used for any purpose other than that for which it is supplied nor may any information contained in it be disclosed to unauthorised persons. It must not be reproduced in whole or in part without obtaining written permission from TE Connectivity (TE).*

While TE has made every reasonable effort to ensure the accuracy of the information in this catalog, TE does not guarantee that it is error-free, nor does TE make any other representation, warranty or guarantee that the information is accurate, correct, reliable or current. TE reserves the right to make any adjustments to the information contained herein at any time without notice. TE expressly disclaims all implied warranties regarding the information contained herein, including, but not limited to, any implied warranties of merchantability or fitness for a particular purpose. The dimensions in this catalog are for reference purposes only and are subject to change without notice. Specifications are subject to change without notice. Consult TE for the latest dimensions and design specifications.

\*Trademark. TE Connectivity, TE connectivity (logo), and TE (logo) are trademarks. Other logos, product and/or company names may be trademarks of their respective owners.

# INSTRUCTION



## Table of Contents

1. INTRODUCTION.....	3
1.1. Safety.....	3
2. PRINTHEAD TESTS.....	4
2.1. Test grid printout examples.....	5
3. PRINTHEAD SETUP.....	6
3.1. Preparing the printer for adjustment.....	6
4. PRINTHEAD ALIGNMENT.....	7
4.1. Adjusting the printhead position.....	7
5. PRINTHEAD PRESSURE.....	8
5.1. Adjusting the printhead pressure.....	8
6. TRANSFER RIBBON ADJUSTMENTS.....	9
6.1. Adjusting the transfer ribbon feed path.....	9
7. REPLACING THE PRINTHEAD.....	10
8. REPLACING THE DRIVE ROLLER.....	12
9. ORDER DETAILS AND RELATED TE DOCUMENTS.....	13
9.1. Related parts order details.....	13
9.2. Related TE documents.....	13

# INSTRUCTION



## 1. INTRODUCTION

All TE Connectivity (TE), printers are optimised for a wide range of printable TE media with different print surfaces, thickness and formats.

It is sometimes necessary to make small adjustments to the printer and software to give an acceptable print contrast.

The following print quality imperfections may indicate the necessity to adjust the print mechanism:

- Print image is too light.
- Print image is spotty.
- Print image is lighter on one side.
- Horizontal printed lines are not parallel to the horizontal label edges.
- Clear lateral drift of the transfer ribbon (ribbon crease).

### Note!

Before making any adjustments to the print mechanism, ensure that the surfaces to be printed on, are clean and free of dust and debris, and that the drive roller is in good condition.

Print image defects can also arise from wrinkling transfer ribbon.

Always check the transfer ribbon the feed path is correct before making any print mechanism adjustment. Ensure the recommended transfer ribbon combination is being used by checking TE document 411-121005, Identification Printer Product Ribbon Matrix.

### 1.1. Safety

- Whenever working on a printer for repair or maintenance, always ensure that the printer is switched off and disconnected from its power source.
- Allow a minimum of two minutes to elapse for any stored capacitive energy to discharge.
- When changing any electrostatic-sensitive devices, ensure electrostatic discharge precautions are taken.
- Always follow local safety rules.
- Always use the correct tool for each job.

TE recommend that maintenance and repair of printers, is carried out by a qualified engineer. For contact details of your regional TE Technical Support Engineer, please use the following link:

[Technical Support](#)



## 2. PRINthead TESTS

If the quality of printing is bellow standard, it is recommended to carry out printer tests before commencing with any adjustments. For all printer tests, load a roll of labels or continuous paper 106mm wide, together with the appropriate ribbon. With the printer powered up showing the "Ready" screen, select the "Setup" Icon.

In the "Setup" screen, select "Test".

Within the "Test" menu there are two printer tests, that can help diagnosing the print quality and the state of the Printhead.

In the "Test" menu select "Status Print" this is particularly useful when conveying information to TE Technical support.

To check printhead health and Horizontal alignment, select "Test Grid" and initiate the print.

Print outs are stopped by selecting cancel.

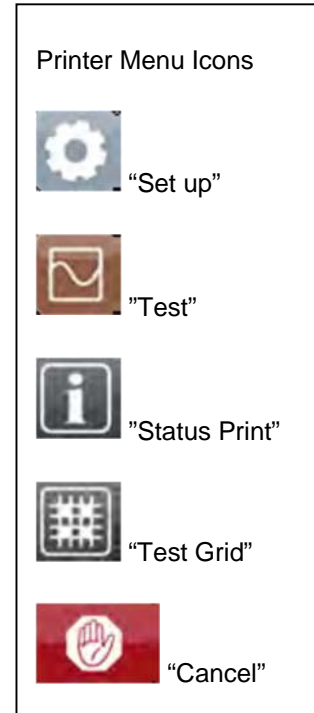



## 2.1. Test grid printout examples

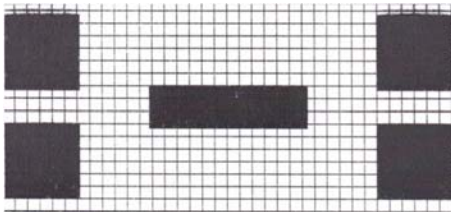

Figure 1, healthy printhead.

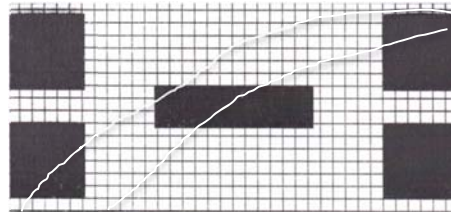

Figure 2, ribbon crease.

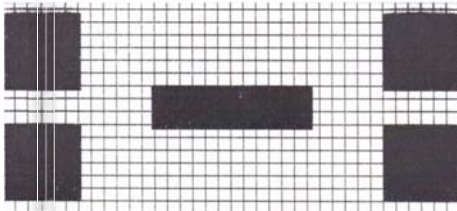

Figure 3, damaged printhead.

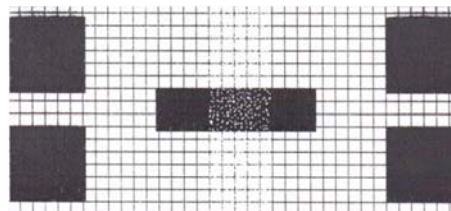

Figure 4, worn roller.

Figure 1, is an example of a healthy printhead, with no need for any printhead adjustment, please check product and ribbon.

Figure 2, shows evidence of ribbon crease please go to section 6.

Figure 3, exhibits evidence of printhead damage. Clean print head rigorously and retest. ("Thermal Transfer Printhead cleaning instructions" 411-121037).

If printhead cleaning does not improve after the retest, the printhead may need replacing, please go to section 7, or seek advice from TE technical support. [Technical Support](#)

Figure 4, the example in figure 4, shows a faded print. This can point to a worn drive roller. Clean the printhead and drive roller, retest. If there is no improvement after the retest, please replace the drive roller. Drive roller replacement instructions can be found in section 8.



### 3. PRINTHEAD SETUP

#### 3.1. Preparing the printer for adjustment

1. Move the transfer ribbon deflection bar to the central position (1) with screw (2).
2. Position the toggles (4) so the adjustment screws are accessible through the holes (3) of the retaining square bar.
3. Loosen screw (5) half a turn, ready for printhead alignment, with an Allen key (1.5mm), turning counterclockwise for one half turn.
4. Load the transfer ribbon and printable media as described in the printer operator's manual, TE document 412-121035, section 4.

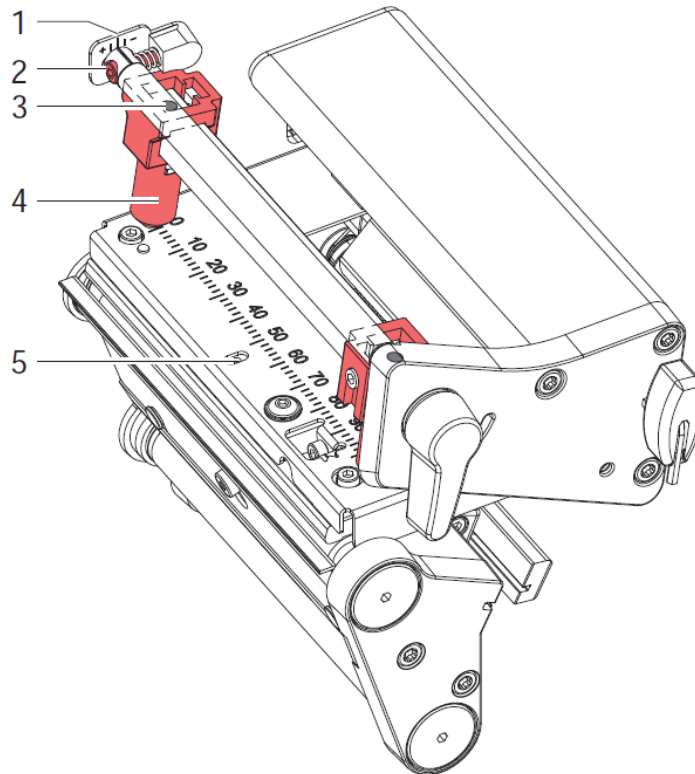

Figure 5, Preparing the printer for adjustment



## 4. PRINthead ALIGNMENT

### 4.1. Adjusting the printhead position

To achieve the best possible print image, the following printhead settings may be necessary:

- Set the horizontal printed lines with the edge of the label.
- Align the heating line of the printhead with the apex (highest point) of the drive roller. Density of the print image is greatest at this point.

#### Note!

Attempting to adjust the printhead when the fixing screw (1) is tight can lead to damage the printhead assembly.

Always loosen screw (1) before adjusting the printhead.

#### Horizontal alignment

1. Loosen screw (1), one half turn.
2. Align mark (3) on the carrier plate to the pointer (4) on the printhead carriage by turning screw (2).
3. Check printhead alignment by printing a suitable label.
4. If horizontal lines are not parallel to the label edges, adjust screw (2).

#### Alignment of printhead heating line to the drive roller apex

1. Set the best possible image quality by turning the cam screw (5).
2. When the highest image quality is achieved, tighten screw (1).

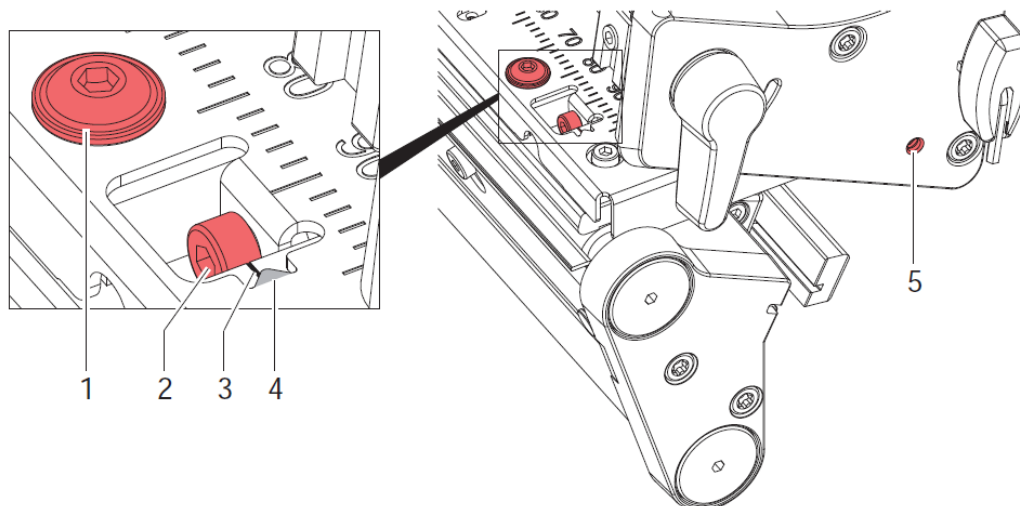

Figure 6, Adjusting the printhead position



## 5. PRINthead PRESSURE

### 5.1. Adjusting the printhead pressure

The printhead pressure can be changed with screws (1a) and (1b) at the inside and outside of the printhead.

Increasing the printhead pressure leads to an improvement of the print image density on the corresponding side and to a shifting of the ribbon feed path to the other side.

#### Caution!

Increasing printhead pressure, can reduce the life of the printhead and drive roller. Always ensure printhead alignment and all other steps are carried out first.

1. Turn the adjustment screws (1a, 1b) counterclockwise until turning becomes perceptibly easy.
2. Check print quality by printing a suitable label.
3. Adjust screws (1a or 1b) clockwise in small increments on the side with the weaker print image, until the print image is even across the entire width.

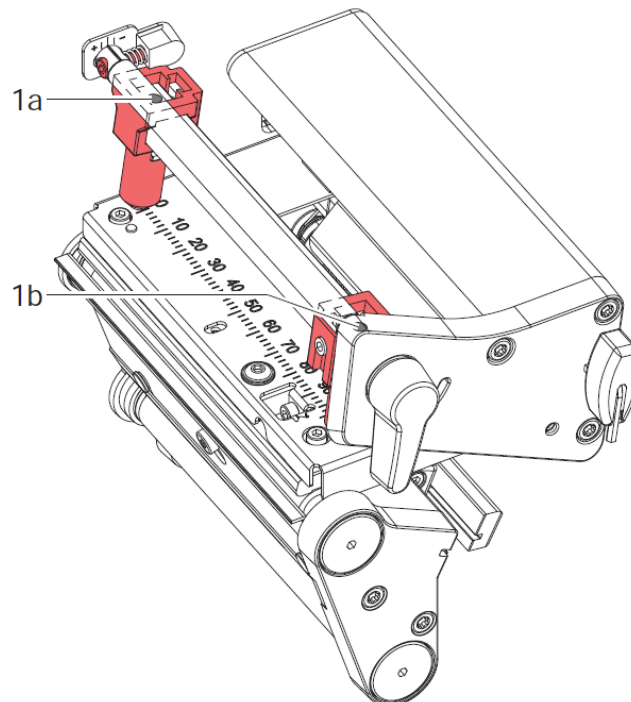

Figure 7, adjusting the printhead pressure





## 6. TRANSFER RIBBON ADJUSTMENTS

### 6.1. Adjusting the transfer ribbon feed path

Adjustment of the transfer ribbon feed path can be achieved by the following methods, changing the printhead contact pressure and adjusting the transfer ribbon deflection bar (3).

Wrinkles, which cannot be remedied with the transfer ribbon deflection bar, can be removed by adjusting the printhead pressure on one side.

1. Check the transfer ribbon feed path. The new ribbon and spent ribbon should be in the same central position on both ribbon spindles, and routed correctly.
2. If the ribbon runs outward, turn screw (2a), or if the ribbon runs inward, turn screw (2b) clockwise, in small increments. Wait until the ribbon feed path has stabilized after each step of the adjustment.
3. Check the ribbon feed path for wrinkles.
4. If wrinkles arise on the inside, turn the screw (1) counterclockwise. If wrinkles arise on the outside, turn the screw (1) clockwise.
5. If the wrinkles cannot be remedied (e.g. wrinkles in the center), turn the adjustment screw (4) clockwise with extreme care, using an Allen key (1.5 mm) and observe the ribbon feed path. When the adjustment screw (4) is tightened, the printhead is bowed downward slightly in the center. It is possible that a slight lightening at the edge areas of the print image could occur here.
6. If bowing of the printhead is not necessary, turn the screw (4) clockwise until the screw is just barely clamping.
7. When the transfer ribbon feed path is set, continue with a final print test.

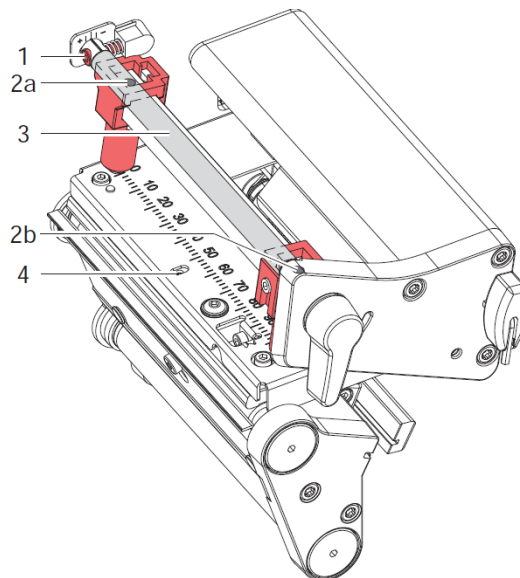

Figure 8, Transfer ribbon adjustment



## 7. REPLACING THE PRINTHEAD

The printhead must be replaced if worn or damaged, and if changing to a printhead with higher or lower resolution.

### Attention!

The Printhead can be damaged by static electrostatic discharges and impacts.

- Set up the printer on a grounded, conductive surface.
- Ground yourself, e.g. by wearing a grounded wristband.
- Do not touch contacts on the plug connections (1, 2).
- Do not touch heating line (5) with hard objects or your hands.

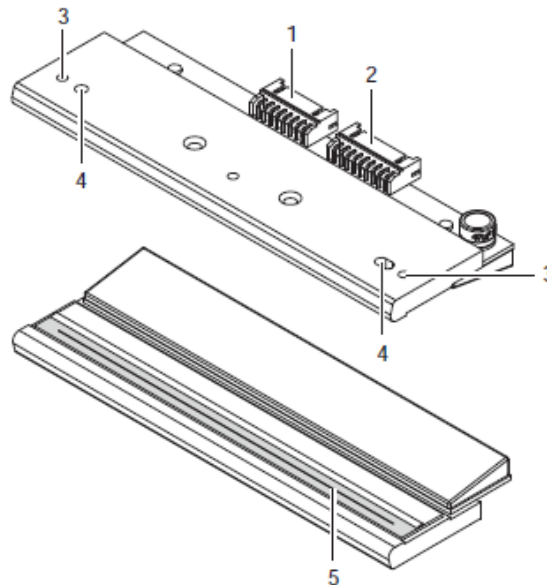

Figure 9, printhead structure.

## INSTRUCTION



### Dismounting the printhead

1. Remove all the media and transfer ribbon from the printer.
2. Close and lock the printhead.
3. Loosen two screws (6).
4. Open the printhead locking and if necessary remove the printhead from the pins (9).
5. First unplug the power cable (8), following the data cable (7).

### Mounting the Printhead

1. First connect the data cable (7), following the power cable (8).
2. Place the printhead into the printhead assembly and insert the pins (9) into the holes (4).
3. Press down the printhead carriage and fix the printhead with the screws (6) at the carriage using the threaded holes (3).
4. Clean the heating line with the cleaning cloth and IPA. (Please consult TE document 411-121037, Thermal Transfer printhead cleaning instructions)
5. Reload media and transfer ribbon.

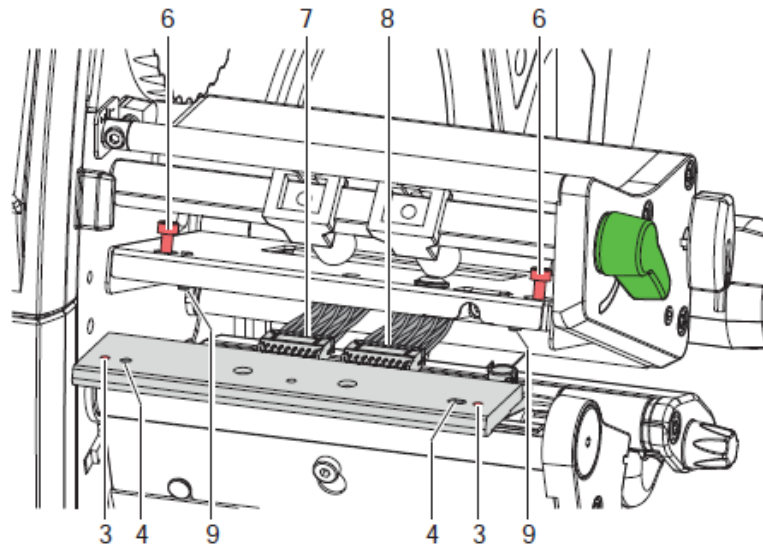

Figure 10, Removing and replacing the printhead.

TE recommend to change the drive roller, if changing the printhead for wear or damage.



## 8. REPLACING THE DRIVE ROLLER

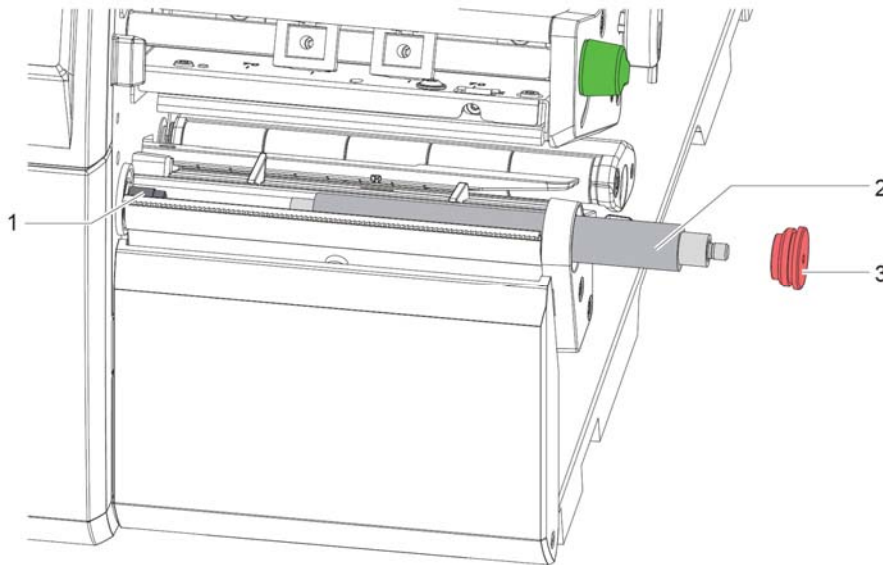

Figure 11, Replacing the drive roller.

### Mounting the Printhead

1. First open the printhead.
2. Remove labels and transfer ribbon from the printer.
3. Unscrew the retention screw (3) with a 1.5mm Allen key.
4. Pull the drive roller (2) through the side plate.
5. Insert a replacement drive roller (2) through the side plate engaging the hexagonal drive (1).
6. Replace the retention screw (3) with the 1.5mm Allen key.

# INSTRUCTION



## 9. ORDER DETAILS AND RELATED TE DOCUMENTS

### 9.1. Related parts order details

ITEM	DESCRIPTION	PART NUMBER
PRINTER	T3212-PRINTER	1-2186500-1
PRINTER	T3224-PRINTER	1-2186502-1
300dpi PRINthead	T3212-PRINTER-PRINthead-300DPI	1-2186504-1
600dpi PRINthead	T3224-PRINTER-PRINthead-600DPI	1-2186506-1
Drive roller	T3200-PRINTER-DRIVE-ROLLER	1-2186505-1

### 9.2. Related TE documents

411-121005	Identification Printer Product Ribbon Matrix
TTDS-257	PRINTING RIBBONS AND INKS TECHNICAL DATASHEET
411-121002	Print Contrast Reference Scale
412-121035	Operators Manual T3212 T3224 PRINTER
TTDS-272	T3212 PRINTER
TTDS-274	T3224 PRINTER
411-121037	Thermal Transfer Printhead cleaning instructions
404-121026	T3212 T3224 PRINTER ILLUSTRATED PARTS LIST
411-121057	IDENTIFICATION SOLUTIONS FIELD SUPPORT CONTACT INFORMATION