



Doc. No: 411-121018

Issue: 1

Date: Oct 2012

## Printhead setup instructions for the TE3124, TE3112 & T6112DS

---

### 1. Introduction

The aim of this document is to provide instruction for setting up the Printhead of the TE Connectivity (TE) thermal transfer (TT) printers TE3124 (CC9352-000), TE3112 (CR2120-000) and T6112DS (CP8122-000) to give an optimum print performance.

The range of products printed on the TE thermal transfer printers TE3124, TE3112 and T6112DS vary in width and thickness. There is **NO** universal adjustment to cover every TE product. It may be necessary to adjust the toggles and printhead for each product printed.

**Note:** Thermal transfer Printheads can be damaged by electrostatic discharge or over current. When ever electrically disconnecting the printhead, the power supply must be disconnected and allowed to dissipate for at least 1 minute.

The printhead surface can be physically damaged and so must be treated with care. Tools must not be used on the printhead surface and only the recommended cleaners (TE – Thermal Transfer [TT] Printer cleaning Kit CP5431-000) are to be used to clean printheads.

*The information contained within this document is the property of TE Connectivity. It is supplied in confidence and the commercial security of the contents must be maintained. It must not be used for any purpose other than that for which it is supplied nor may any information contained in it be disclosed to unauthorised persons. It must not be reproduced in whole or in part without obtaining written permission from TE Connectivity.*

Author: I Ridgeway  
Print date: 24-Oct-12  
Issue date: : Oct 2012  
Page: 1 of 8

While TE Connectivity has made every reasonable effort to ensure the accuracy of the information in this document, TE does not guarantee that it is error-free, nor does TE make any other representation, warranty or guarantee that the information is accurate, correct, reliable or current. TE reserves the right to make any adjustments to the information contained herein at any time without notice. TE expressly disclaims all implied warranties regarding the information contained herein, including, but not limited to, any implied warranties of merchantability or fitness for a particular purpose. The dimensions in this document are for reference purposes only and are subject to change without notice. Specifications are subject to change without notice. Consult TE for the latest dimensions and design specifications.  
If this document is printed it becomes uncontrolled

### 2. Printhead set up

**2.1. Toggle Position** - place the pressure toggles (Figure 1) on the edges of the printable area.

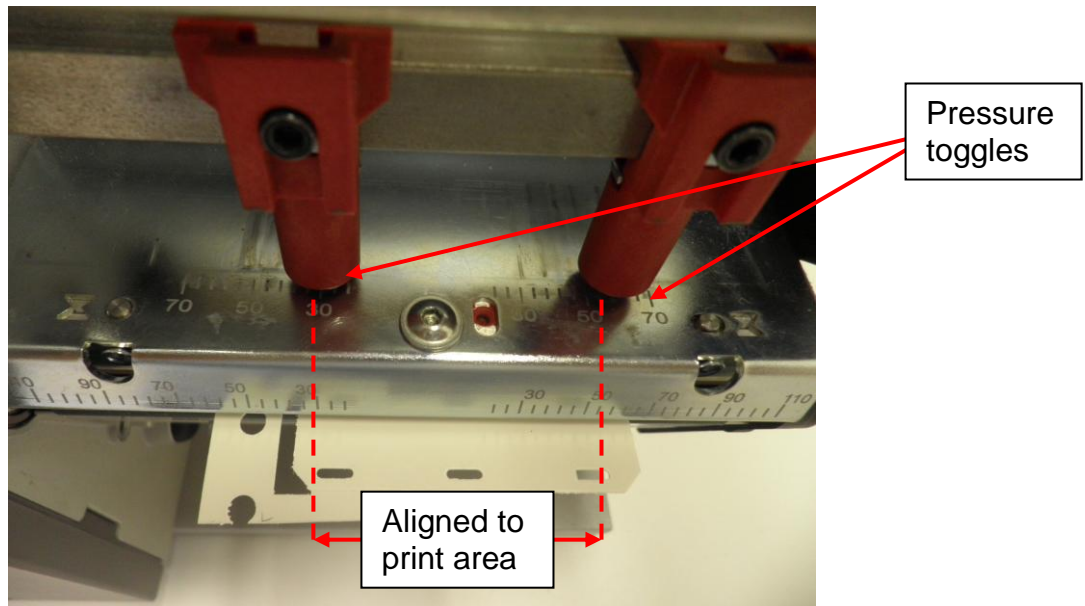
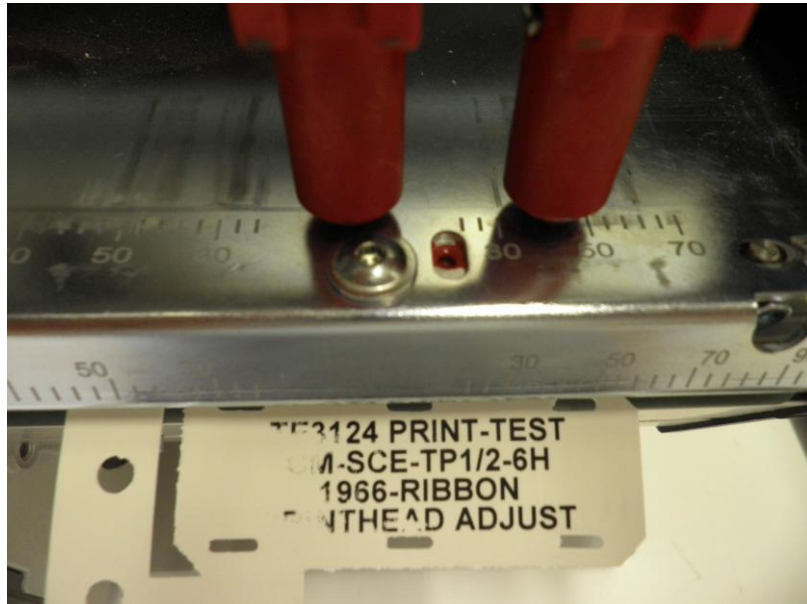

**Figure 1 - Pressure toggles setup for print area of product to be printed.**

Incorrect alignment of pressure toggles can give poor print quality, see Figure 2. Position of pressure toggles should be optimised for the material printed and is dependant on width on material printed.

The pressure toggles may be tightly clamped to the printhead locking bar so movement may be restricted. In this instance loosening the grub screws a quarter turn (see Figure 3) will aid movement. If grub screws loosened, re-tighten when pressure toggles positioned in correct location.

## Printhead setup instructions for the TE3124, TE3112 & T6112DS



**Figure 2 - Pressure toggles incorrectly positioned,  
showing resultant poor print quality**

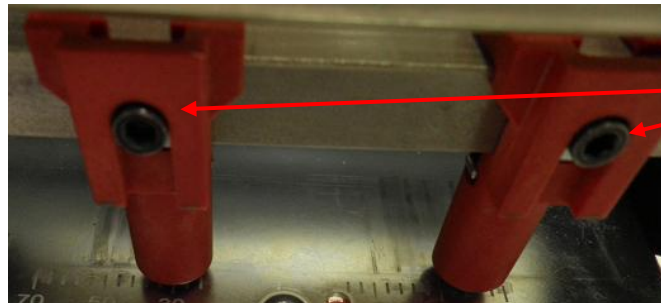

Pressure toggles  
grub screws

**Figure 3 - Pressure toggle grub screws**

## Printhead setup instructions for the TE3124, TE3112 & T6112DS

**3. Printhead alignment.** When the pressure toggles have been correctly positioned, select and load the recommended thermal transfer ribbon and product combination, see “Identification printer product ribbon matrix” TE document number 411-121005.

**3.1.** Close the Printhead and carry out a test print to the printer. Examine the print quality; if the print quality is not acceptable an adjustment to the printhead position may be required.

**3.2.** Figure 4 shows a misalignment of the printhead resulting in poor print quality, (imbalance – as shown by the alignment witness marks **NOT** being similarly located)

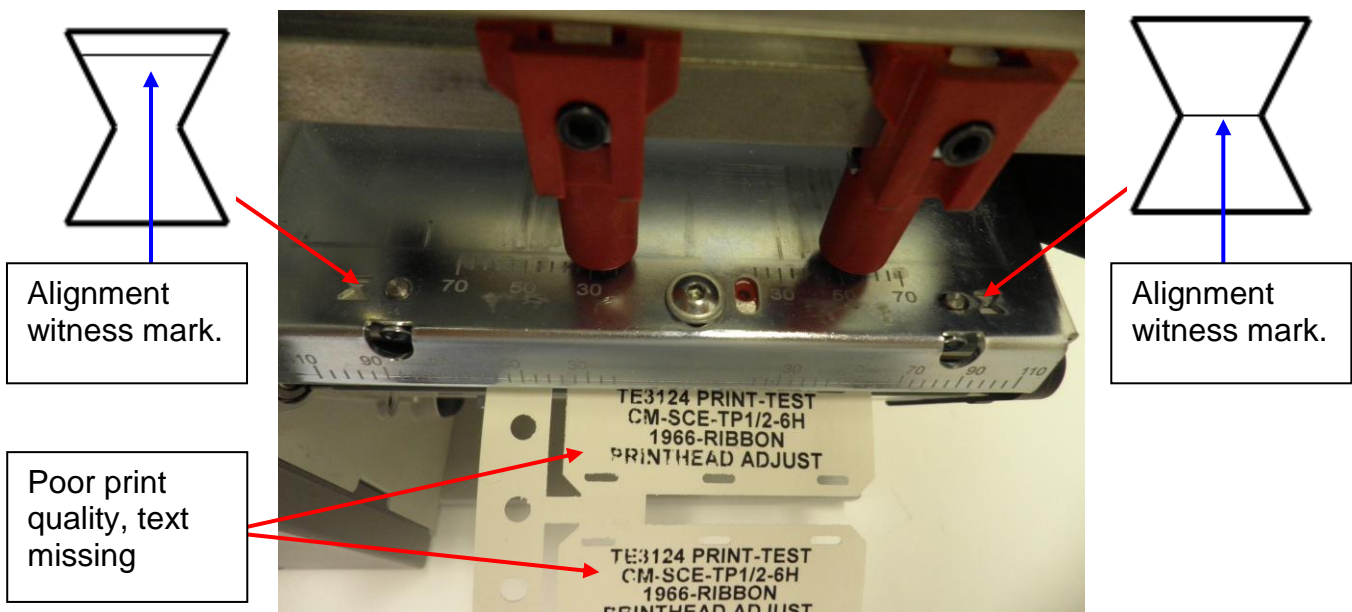

**Figure 4 - Example of print that requires printer printhead alignment.**

## Printhead setup instructions for the TE3124, TE3112 & T6112DS

- 3.3. When aligning the printhead ensure **both** sides of the printhead start from the factory default position with the alignment witness mark in the centre of the inspection window as shown in Figure 5.

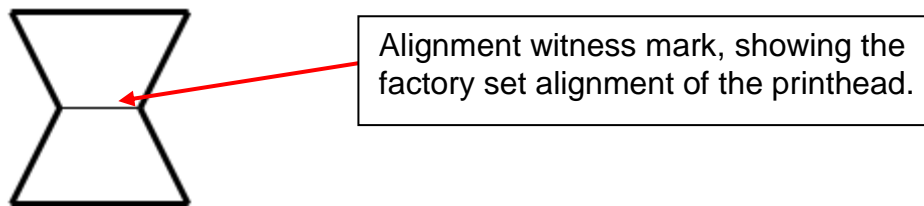

Figure 5 – Factory Default

- 3.4. To align the printhead, remove the ribbon from the printer and loosen the printhead retaining screw marked “A” shown in Figure 6 with the tool provided with the printer shown in Figure 6.

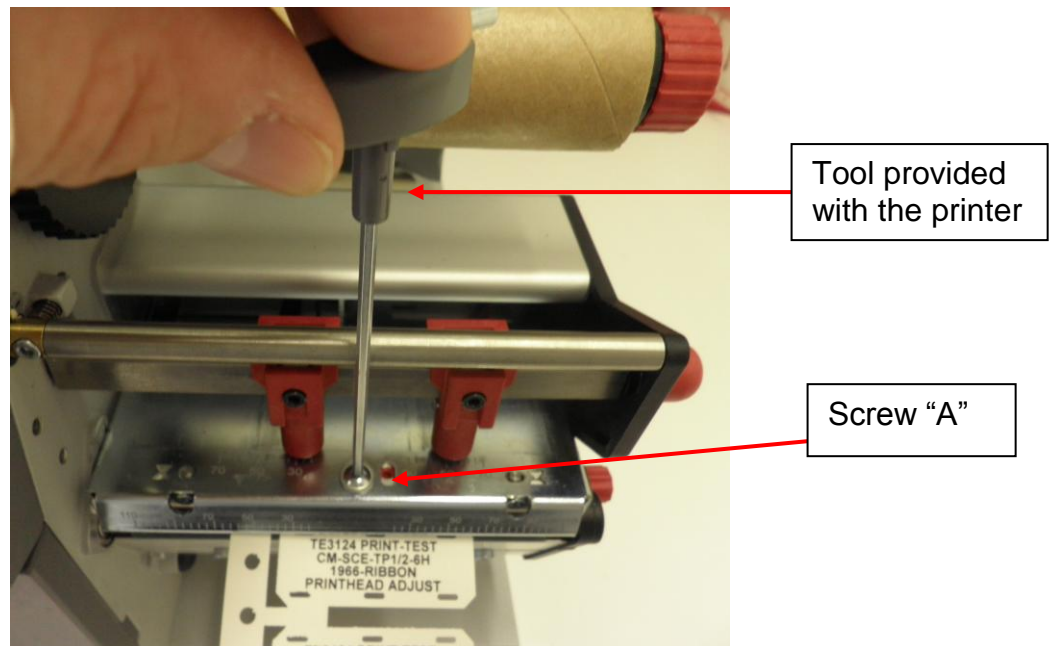

Figure 6- Printhead loosening

## Printhead setup instructions for the TE3124, TE3112 & T6112DS

- 3.5.** With screw “A” loose, ensure printhead starting position is with alignment marks in factory set position. If the print head is not in the factory default position then adjustment has been previously carried out and this may be the cause of the print quality issue. In this instance it is advisable to adjust the print alignment screws B and C (see Figure 7) back to Factory Default, retighten screw A and repeat the print test (step 3 & 3.1).
- 3.6.** If the printhead is in the Factory Default then printhead adjustment may be required. Turn screw B and C one full turn clockwise, see Figure 7) , retighten screw A and repeat the print test (paragraph 3 – 3.1).
- 3.6.1. If the print test result shows an improvement in print quality loosen screw A and repeat step 3.5.
- 3.7.** If the print test result shows a deterioration in print quality loosen screw A and Turn screw B and C two full turns counter-clockwise, see Figure 7) , retighten screw A and repeat the print test (paragraph 3 – 3.1).
- 3.7.1. If the print test result shows an improvement in print quality loosen screw A and Turn screw B and C one full turns counter-clockwise, see Figure 7) , retighten screw A and repeat the print test (paragraph 3 – 3.1).
- 3.7.2. Optimisation of print quality will occur when print quality starts to fall again, in which instance loosen screw A and turn one full turn in the opposite direction, retighten screw A and repeat the print test (paragraph 3 – 3.1).
- 3.8.** If print quality does not improve when adjusting the printhead then this may be a printhead pressure issue, see step 4.

## Printhead setup instructions for the TE3124, TE3112 & T6112DS

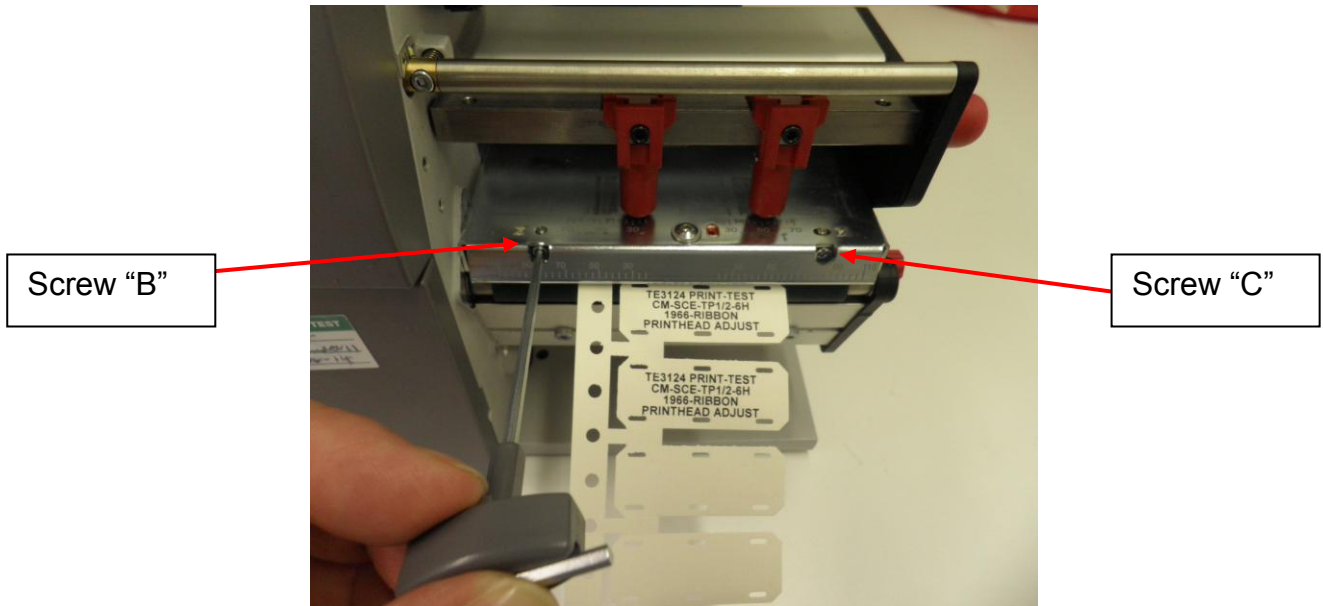

Figure 7 - Printhead alignment screws B and C

**4. Printhead Pressure** - If changing the location of the pressure toggles, and printhead alignment does not improve quality then there may be insufficient head pressure.

**4.1.** To configure the print head pressure, loosen the grub crews holding the pressure toggles, (see Figure 3) and slide both pressure toggles to their receptive left and right limits, see figure 8. This will align the printhead pressure adjustment holes through the printhead locking bar.

## Printhead setup instructions for the TE3124, TE3112 & T6112DS

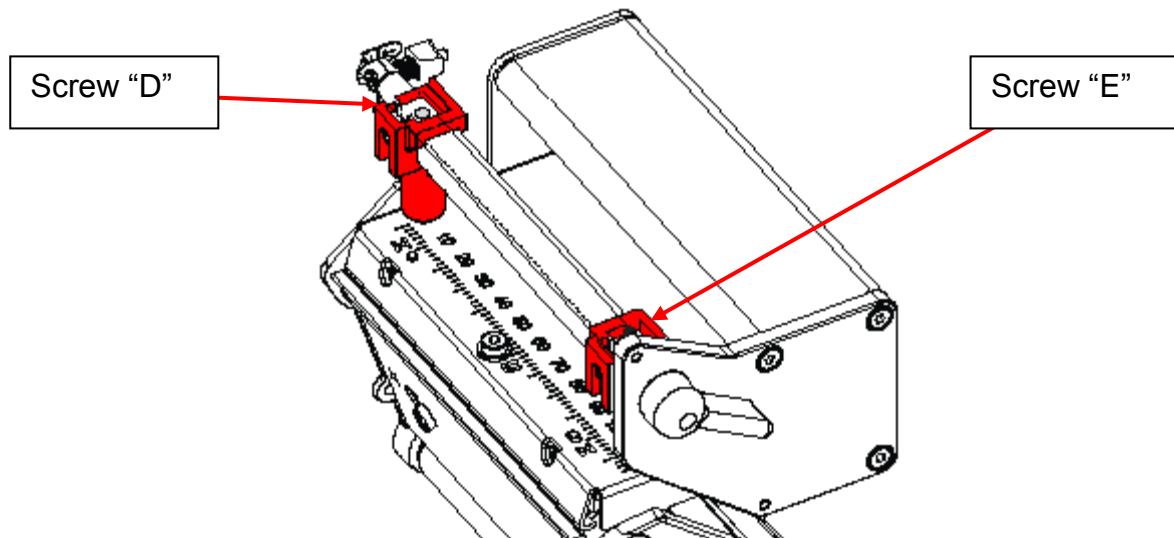

Figure 8 - Printhead pressure adjust

- 4.2. Turn the adjustment screws D and E counter-clockwise until turning become perceptibly easy.
- 4.3. Turn the adjustment screws D and E clockwise in half turn increments. After each turn carry out a test print. **Note:** with pressure toggles positioned at the left and right extremes the print quality will be less than when placed at their optimum position.
- 4.4. Repeat step 4.3 increasing the adjustment on screws D and E in a clockwise direction until print quality has reached a satisfactory quality.
- 4.5. When print quality is at an optimum return the pressure toggles to their optimum position with regards to product and carry out a test print. When adjustment complete retighten up pressure toggle grub screws (see Figure 3)
- 4.6. **DO NOT** adjust screws D and E to the maximum clockwise position as this will shorten printhead life. If maximum clockwise position is reached then the user **must** turn screws D and E one half turn counter-clockwise.
- 4.7. If print quality does not reach a satisfactory level then contact a TE representative.