

AMP

of Great Britain Ltd.

APPLICATION AND MAINTENANCE
INSTRUCTION FOR STRAIGHT
ACTION HANDTOOLS
LISTED

INSTRUCTION SHEET

IS 1140 GB

RELEASED	3-'85
REVISED	-

SECTION 1 of this instruction sheet provides application procedures for AMP hand crimping tools

SECTION 2 provides maintenance and inspection procedures for AMP hand crimping tools

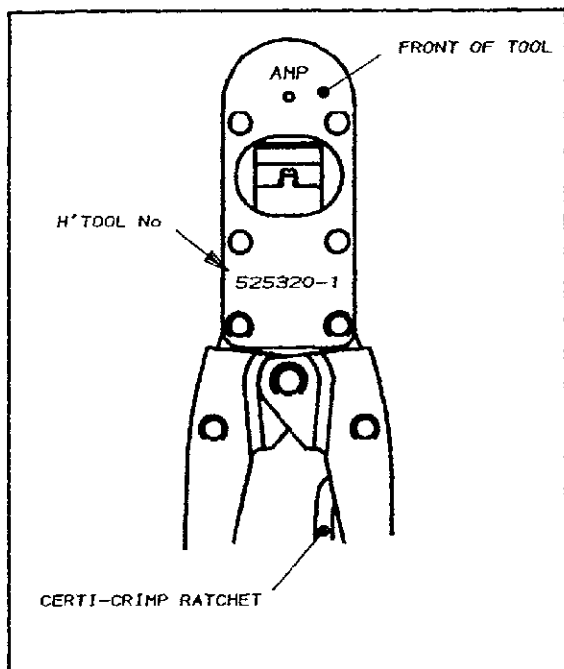

Fig.1-1

TOOL No (ALL dash Nos)	APP SPEC No
525320	114-3112

Fig.1-2

SECTION 1

APPLICATION

1-1 INTRODUCTION

This instruction sheet is to be used for general information on use and maintenance of tools listed fig.1-2. Read these instructions thoroughly before crimping any terminals.

1-2 DESCRIPTION

This tool comprises of fixed crimpers and moveable anvils, a terminal support, a locator/wire stop and a CERTI-CRIMP ratchet. The terminal support prevents the terminal from bending during the crimping procedure

The locator/wire stop has two functions. It is used to position the wire within the terminal and the terminal within the tool.

The CERTI-CRIMP ratchet assures that a full crimp is applied to the terminal. Once engaged, the ratchet will not release until the tool handles have been fully closed.

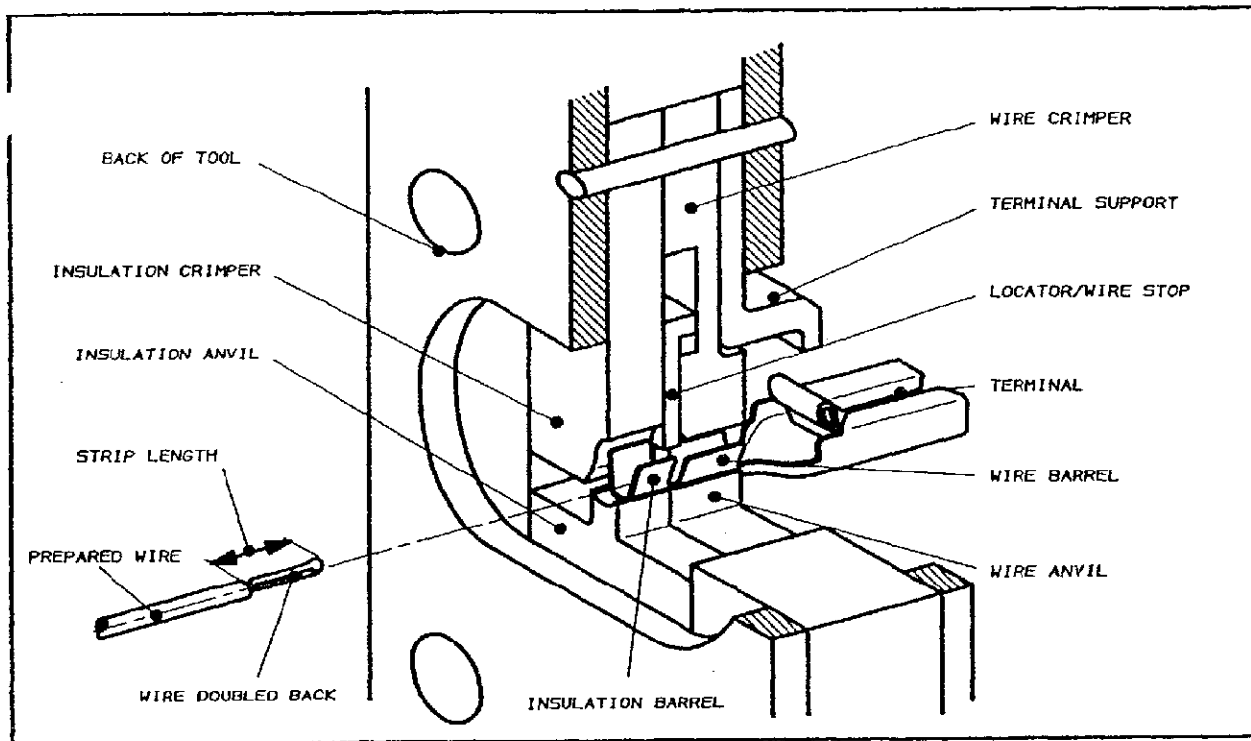

Fig. 1-3

1-3 CRIMPING PROCEDURE

Using the appropriate APPLICATION SPEC (see Fig. 1-2) Select a wire within the specified wire range and strip to length shown, taking care not to cut or nick the strands.

Notice that each crimp station of the tool has the applicable wire size marked above it. Use these markings and the wire size used to determine the proper crimp station to use. Select a terminal and proceed as follows:

1. Hold the tool so that its BACK is facing you.
2. Make certain that the ratchet is released by squeezing the tool handles and allowing them to open fully.

Looking straight into the crimping dies from the BACK of the tool, insert a terminal (insulation barrel first) into the FRONT of the tool

4. Position the terminal in the crimper so that the locator enters the locator slot of the terminal.
5. While holding the terminal in this position, squeeze the tool handles until the dies close just enough to hold the terminal in position. Do NOT deform the wire barrel.
6. Insert a properly stripped wire into the terminal until it butts against the locator/wire stop.
7. Hold the wire in place and squeeze the tool until the ratchet releases.
8. Allow the tool handles to open fully and remove the crimped terminal.

SECTION 1 of this instruction sheet provides application procedures for AMP hand crimping tools. **SECTION 2** provides maintenance and inspection procedures for AMP hand crimping tools.

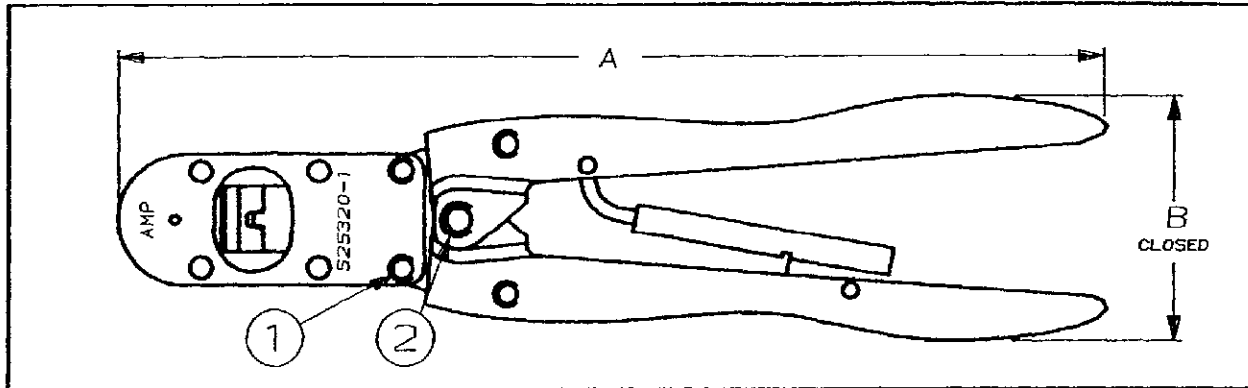

TOOL SPECIFICATION		ITEM	PART NUMBER	DESCRIPTION	QTY
DIMENSION	WEIGHT	1	21045-3	RING RETAINING	8
A 295mm	0.6Kg	2	21045-6	RING RETAINING	2
B 76mm		CAUTION: DO NOT REMOVE THE RETAINING PINS, OR PERMANENT DAMAGE TO THE TOOL MAY RESULT (See para 2-3)			
MAX DEPTH 25mm					

Fig.2-1

SECTION 2 MAINTENANCE/INSPECTION

2-1 TOOL INSPECTION

These instructions have been approved by AMP Design, Production, and Quality Control Engineers to provide documented maintenance and inspection procedures. The procedures described herein have been established to ensure quality and reliability of AMP hand crimping tools.

Customer replaceable parts are listed in Figure 2-1. A complete inventory should be stocked and controlled to prevent lost time when replacement of parts is necessary. When kit items are needed, order replacement kit part no.

2-2 INSPECTION PROCEDURE

A. DAILY MAINTENANCE

It is recommended that each operator of the tool be made aware of and responsible for the following four steps of daily maintenance:

1. Remove dust, moisture, and other contaminants with a clean brush, or soft lint-free cloth. Do NOT use objects that could damage the tool.

2. Make sure that the retaining pins are in place and secured with the proper retaining rings.
3. Make certain all pins, pivot points and bearing surfaces are protected with a THIN coat of any good SAE No.20 motor oil. Do NOT oil excessively.
4. When the tool is not in use, keep the handles closed to prevent objects from becoming lodged in the crimping dies and store the tool in a clean, dry area.

B. PERIODIC INSPECTION

Regular inspections should be performed by quality control personnel. A record of scheduled inspections should remain with the tool and/or be supplied to supervisory personnel responsible for the tool. Though recommendations call for at least one inspection a month, the inspection frequency should be based on the amount of use, ambient working conditions, operator training and skill, and established company standards. These inspections should be performed in the following sequence.

B-1 VISUAL INSPECTION

1. Remove all lubrication and accumulated film by immersing the tool (handles partially closed) in a suitable commercial degreaser that will not affect paint or plastic material.
2. Make certain all retaining pins are in place and secured with retaining rings. If replacements are necessary, refer to parts listed in Fig 2-1.
3. Close the tool handles until the ratchet releases, then allow handles to open freely. If they do not open quickly and freely, the spring is defective and must be replaced [see Paragraph 2-3 REPAIR]

Inspect the head assembly with special emphasis on checking for worn, cracked, or broken dies. If damage to any part of the head assembly is evident, return to AMP for evaluation and repair [see Paragraph 2-3, REPAIR]

B-2 CRIMP HEIGHT INSPECTION

This inspection requires the use of a micrometer with a modified anvil as shown in Figure.2-2. We recommend the modified micrometer [Crimp height comparator 2-576692-0] from:
AMP [Gt. Britain] Ltd.
Lennion Ave., Stanmore, Middlesex.

Proceed as follows:

1. Refer to the appropriate APPLICATION SPEC See Fig 1-1, for the required terminal/wire combination.
2. Refer to paragraph 1-3, CRIMPING PROCEDURE and crimp the terminals accordingly.
3. Using a crimp height comparator measure wire barrel crimp height as shown in Figure 2-2. If the crimp height conforms to that shown in the APPLICATION SPEC, the tool is considered dimensionally correct. If not return the tool to AMP for evaluation and repair (see para 2-3 REPAIR)

For additional information concerning the use of the crimp height comparator refer to AMP Instruction Sheet IS 7424

B-3 CERTI-CRIMP RATCHET INSPECTION

Obtain a 0.025mm shim that is suitable for checking the clearance between the bottoming surfaces of the crimping dies.

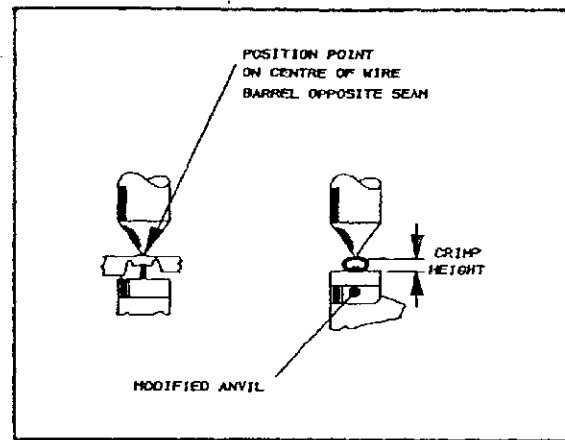

Fig.2-2

Proceed as follows:

1. Select the MAXIMUM terminal/wire combination, see APPLICATION SPEC.
2. Position the terminal and wire between the crimping dies, according to Paragraph 1-3, CRIMPING PROCEDURE [Steps 1 through 6]. Holding the wire in place, squeeze the tool handles together until the CERTI-CRIMP ratchet releases. Hold the tool handles in this position, maintaining just enough pressure to keep the dies closed.
3. Check the clearance between the bottoming surfaces of the crimping dies. If the clearance is 0.025mm. or less, the ratchet is satisfactory. If clearance exceeds 0.025mm., the ratchet is out of adjustment and must be repaired [see Paragraph 2-3, REPAIR].

If the tool conforms to these inspection procedures, lubricate it with a THIN coat of any good SAE No.20 motor oil and return it to service.

2-3 REPAIR

Parts other than those specified in Figure 2-1 must be replaced by AMP to ensure quality and reliability of the tool. When repair is necessary, return the tool with a written description of the problem to:

AMP [Great Britain] Ltd
Tool Repair Section
Industrial Estate
Port Glasgow
Renfrewshire

or a wholly owned subsidiary of AMP Incorporated