

customer manual

ORIGINAL INSTRUCTIONS

SAFETY PRECAUTIONS	READ THIS FIRST !	2
1. INTRODUCTION		5
2. RECEIVING/INSPECTION		5
3. INSTALLATION/REMOVAL OF SDE CRIMP DIES		5
3.1. Installation of SDE Crimp Dies		5
3.2. Removal of Shouldered and Pinned Dies		8
4. OPERATION		8
4.1. Battery Installation and Removal		8
4.2. Crimping		8
5. PREVENTIVE MAINTENANCE		9
5.1. Daily Maintenance		9
5.2. Yearly Maintenance		9
6. SPARE PARTS		9
7. TROUBLESHOOTING		9
8. RETURN		9
9. REVISION SUMMARY		9

Safeguards are designed into this application equipment to protect operators and maintenance personnel from most hazards during equipment operation. However, certain safety precautions must be taken by the operator and repair personnel to avoid personal injury, as well as damage to the equipment. For best results, application equipment must be operated in a dry, dust-free environment. Do not operate equipment in a gaseous or hazardous environment.

Carefully observe the following safety precautions before and during operation of the equipment:

- ALWAYS wear appropriate ear protection.
- ALWAYS wear appropriate eye protection.
- ALWAYS wear approved eye protection when operating powered equipment.
- ALWAYS keep guard(s) in place during normal operation.
- NEVER wear loose clothing or jewelry that may catch in moving parts of the application equipment.
- NEVER insert hands into installed application equipment.
- NEVER alter, modify, or misuse the application equipment.

SAFETY PRECAUTIONS -- IMPORTANT SAFETY INFORMATION

	DANGER
	<p>Electric shock hazard: This tool is not insulated. When using this unit near energized electrical lines, use proper personal protective equipment. Failure to observe this warning could result in severe injury or death.</p>

	DANGER
	<p>Skin injection hazard: Do not use hands to check for oil leaks. High pressure oil easily punctures skin causing serious injury, gangrene, or death. If injured, seek medical help immediately to remove oil.</p>

	DANGER
	<p>Do not use solvents or flammable liquids to clean the crimping tool. Solvents or flammable liquids could ignite and cause serious injury or property damage.</p>

DANGER
<p>Do not dispose of batteries in a fire. They will vent fumes and may explode. Failure to observe this warning could result in severe injury from harmful fumes or burns from flying debris.</p>

DANGER
<p>Inspect tool and dies before use. Replace any worn or damaged parts. A damaged or improperly assembled tool can break and strike nearby personnel. Failure to observe this warning could result in severe injury or death.</p>

DANGER	<p><i>This unit should only be used by trained competent personnel.</i></p>

	<p><i>Read and understand the entire manual before using the equipment.</i></p>
--	---

	<p><i>Always wear approved eye protection when using the equipment.</i></p>
--	---

CAUTION
<ul style="list-style-type: none"> Do not place the tool in a vise. The crimping tool is designed for hand-held operation. Protect the crimping tool from rain and moisture. Water will damage the crimping tool and battery. Use this tool for the manufacturer's intended purpose only. <p>Failure to observe these precautions may result in injury or property damage.</p>

CAUTION
<p>Do not allow anything to contact the battery terminals.</p> <ul style="list-style-type: none"> Do not immerse the batteries in liquid. Liquid may create a short circuit and damage the battery. If batteries are immersed, contact your service center for proper handling. Do not place the battery into a pocket, tool pouch, or tool box with conductive objects. Conductive objects may create a short circuit and damage the battery. Do not place a battery on moist ground or grass. Moisture may create a short circuit and damage the battery. <p>Failure to observe these precautions may result in injury or property damage.</p>

CAUTION
<ul style="list-style-type: none"> Do not store the battery at more than 60 °C (140 °F). Damage to the battery can result. Do not use another manufacturer's charger. Other manufacturers' chargers may overcharge and damage the battery. Do not attempt to open the battery. It contains no user-serviceable parts. <p>Failure to observe these precautions may result in injury or property damage.</p>

CAUTION
<p>Do not perform any service or maintenance other than as described in this manual. Injury or damage to the tool may result. Failure to observe this precaution may result in injury and property damage.</p>

NOTE: Keep all decals clean and legible, and replace when necessary.

TOOLING ASSISTANCE CENTER

CALL TOLL FREE 1-800-722-1111 (CONTINENTAL UNITED STATES AND PUERTO RICO ONLY)

The **Tooling Assistance Center** offers a means of providing technical assistance when required.

In addition, Field Service Specialists are available to provide assistance in the adjustment or repair of the application equipment when problems arise which your maintenance personnel are unable to correct.

INFORMATION REQUIRED WHEN CONTACTING THE TOOLING ASSISTANCE CENTER

When calling the Tooling Assistance Center regarding service to equipment, it is suggested that a person familiar with the device be present with a copy of the manual (and drawings) to receive instructions. Many difficulties can be avoided in this manner.

When calling the Tooling Assistance Center, be ready with the following information:

1. Customer name
2. Customer address
3. Person to contact (name, title, telephone number, and extension)
4. Person calling
5. Equipment number (and serial number if applicable)
6. Product part number (and serial number if applicable)
7. Urgency of request
8. Nature of problem
9. Description of inoperative component(s)
10. Additional information/comments that may be helpful

BATTERY TOOL KIT	REGION OF USE	BATTERY CHARGER	BATTERY CHARGER VOLTAGE	RAM RETRACT SWITCH
1213890-1	North America	1725840-1	110 V	Yes
1213890-2	Europe	1725840-2	220 V	Yes
1213890-3	North America	1725840-1	110 V	No
1213890-4	Europe	1725840-2	220 V	No
1213890-5	United Kingdom	1725840-3	220 V	Yes

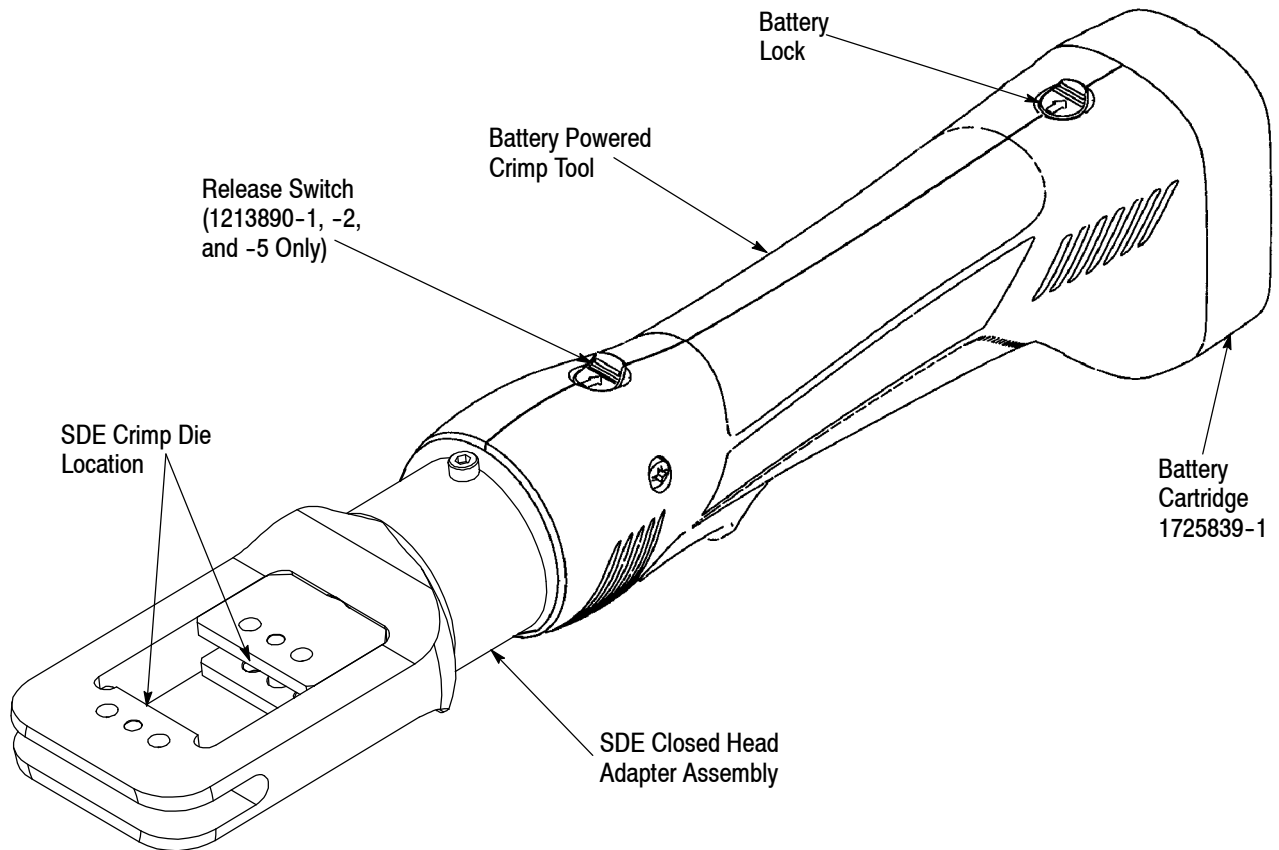

CRIMPING TOOL (with Battery Installed)

Length	349 mm [13 3/4 In.]
Width	60 mm [2 3/8 In.]
Depth	80 mm [3 1/8 In.]
Mass/Weight (w/Battery)	1.5 kg [3.4 lb.]
Sound Level	75 dBA at 1 Meter
Vibration	< 2.5 m/s ²
Hydraulic Oil	Shell Tellus® T 15

CRIMPING CAPACITIES

Maximum Crimping Force	15.6 kN [1.75 Tons]
Average Crimping Time	2 Seconds
Average Crimps Per Charge	Approximately 150

BATTERY

Charging Voltage	9.6 V
Charging Time	40 Min

Figure 1

1. INTRODUCTION

SDE Closed Head Battery Powered Crimp Tool Kit 1213890-[] consists of the SDE Battery Powered Crimp Tool (with the SDE Closed Head Assembly installed), as well as two rechargeable battery cartridges (1725839-1) to power the tool. See Figure 1. Each kit has a battery charger. The battery charger part number, its voltage, and the kit's region of use are listed in the table below. A battery tool may have a release switch to retract the ram as listed in the table on Page 3. The SDE Closed Head Battery Powered Crimp Tool is designed to accept interchangeable die assemblies used in PRO-CRIMPER* III hand crimping tools for crimping various types of connectors.

2. RECEIVING/INSPECTION

SDE Closed Head Battery Powered Crimp Tool Kit 1213890-[] is thoroughly inspected during and after assembly. Prior to packaging and shipping, a final series of tests and inspections is made to ensure proper function of the tool. The following inspection should be performed as a safeguard against potential problems generated in transit.

1. In a well-lighted area, carefully uncrate the tool and inspect each component as it is removed from the crate.
2. Thoroughly inspect each component for evidence of damage that may have occurred in transit. If any of the components are damaged, file a claim against the carrier and notify TE Connectivity immediately.
3. Keep this manual and all drawings and product samples with the tool for the benefit of operation and maintenance personnel.

The crimp tool should be inspected at regularly scheduled intervals, depending on care, degree of operator skill, the type and size of product being crimped, and environmental conditions. At a minimum, the tool should be inspected after every 40 hours of use.

3. INSTALLATION/REMOVAL OF SDE CRIMP DIES

CAUTION *Do not operate the tool without the SDE Crimp Head Installed. Damage to the ram or seals can result.*



CAUTION *Do not operate the tool without the SDE dies. Damage to the crimp head can result.*



SDE Closed Head Battery Powered Crimp Tool 1213890-[] comes with the crimp head already installed on the battery-powered hand tool. The only installation required is the installation of the SDE dies.

DANGER *To avoid personal injury, be sure to exercise extreme caution when handling the crimp tool. Remove the battery before installing or removing crimp dies.*



3.1. Installation of SDE Crimp Dies

CAUTION *These instructions are specific to the use of TE SDE Crimp Dies. Be sure to use ONLY TE Crimp Dies.*



NOTE *The SDE Battery Operated Crimp Tool cannot be used to crimp parallel splices.*



A. Installation of Shouldered Dies (Figure 2)

1. Remove the battery from the tool.
2. Remove the two die retaining screws from the crimp head.
3. Remove the ram plate from the moving jaw.
4. Place the upper die in the upper portion of the tool head so that the largest indenter is on the right.
5. Insert the die retaining screw through the upper jaw and through the die. Tighten the screw *just enough* to hold the die in place. Do *NOT* tighten the screw completely at this time. See Figure 2.
6. Place the lower die in the moving jaw of the crimp head so that the largest anvil is on the right.
7. Place the ram plate on the moving jaw. The chamfers on the corners of the ram plate should be located adjacent to the die set.
8. Insert the die retaining screw through the ram plate; die set, and the moving jaw. Tighten the screw *just enough* to hold the die in place. Do *NOT* tighten the screw completely at this time.
9. Replace the battery and pulse the trigger to slowly close the crimp head, making sure the anvils and indenters are properly aligned.
10. When the anvils and indenters are aligned, tighten the retaining screws.

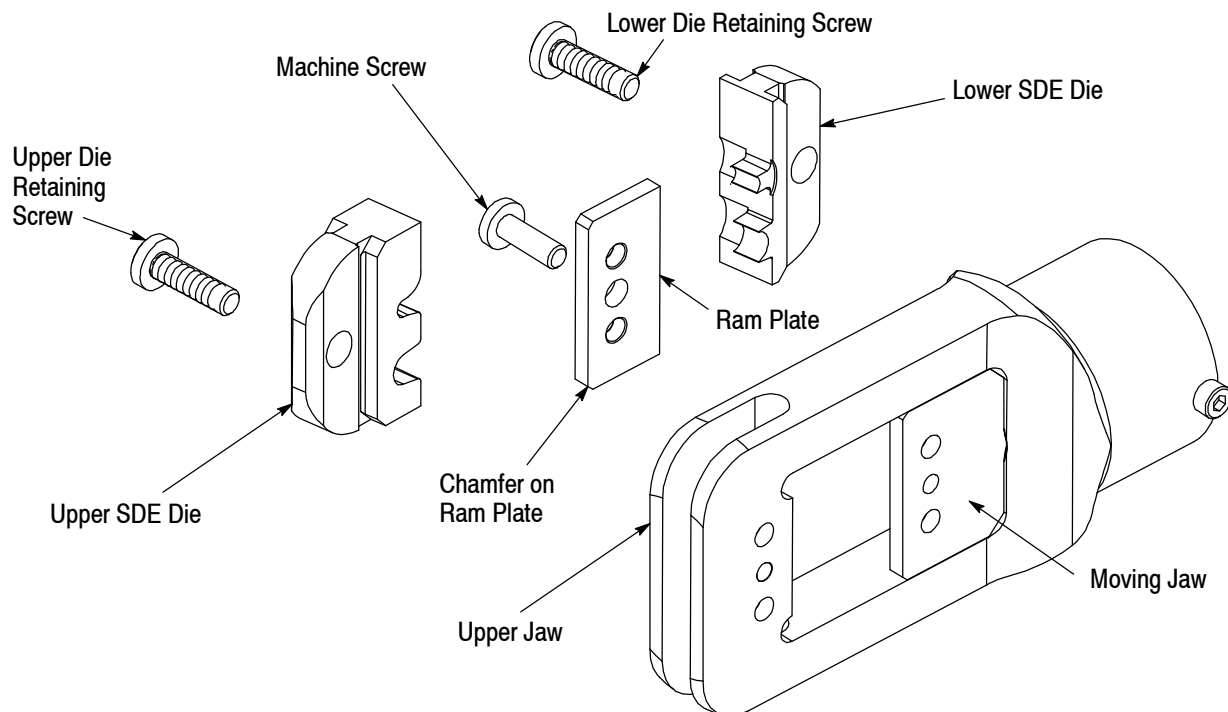

Figure 2

B. Installation of Pinned Dies (Figure 3)

1. Remove the battery from the tool.
2. Remove the two die retaining screws from the crimp head.



Be sure to keep the die retaining screws. Although they will not be required to install pinned dies, you may need them for future use.

3. Remove the ram plate from the moving jaw.
4. Install the anvil die into the moving jaw of the crimp head. The die assembly should be oriented so that the chamfers are positioned to the left of the head assembly, and the die markings are facing outward.
5. Place the ram plate on the moving jaw. The chamfers on the corner of the ram plate should be located adjacent to the die set.
6. Insert two die retaining pins and the short die retaining screw into the ram plate, through the anvil die and moving jaw. Tighten the screw just enough to hold the die in place. Do **NOT** completely tighten the screw at this time.
7. Install the crimper die into the upper jaw of the crimp head. The die should be oriented so that the chamfers are positioned to the left of the head assembly and the die markings are facing outward.
8. Insert two die retaining pins and the long die retaining screw into the upper jaw and through the crimper die. Tighten the screw just enough to hold the die in place.
9. Replace the battery and check the die alignment by pulsing the trigger to slowly close the head, making sure the anvil and indenter are properly aligned.

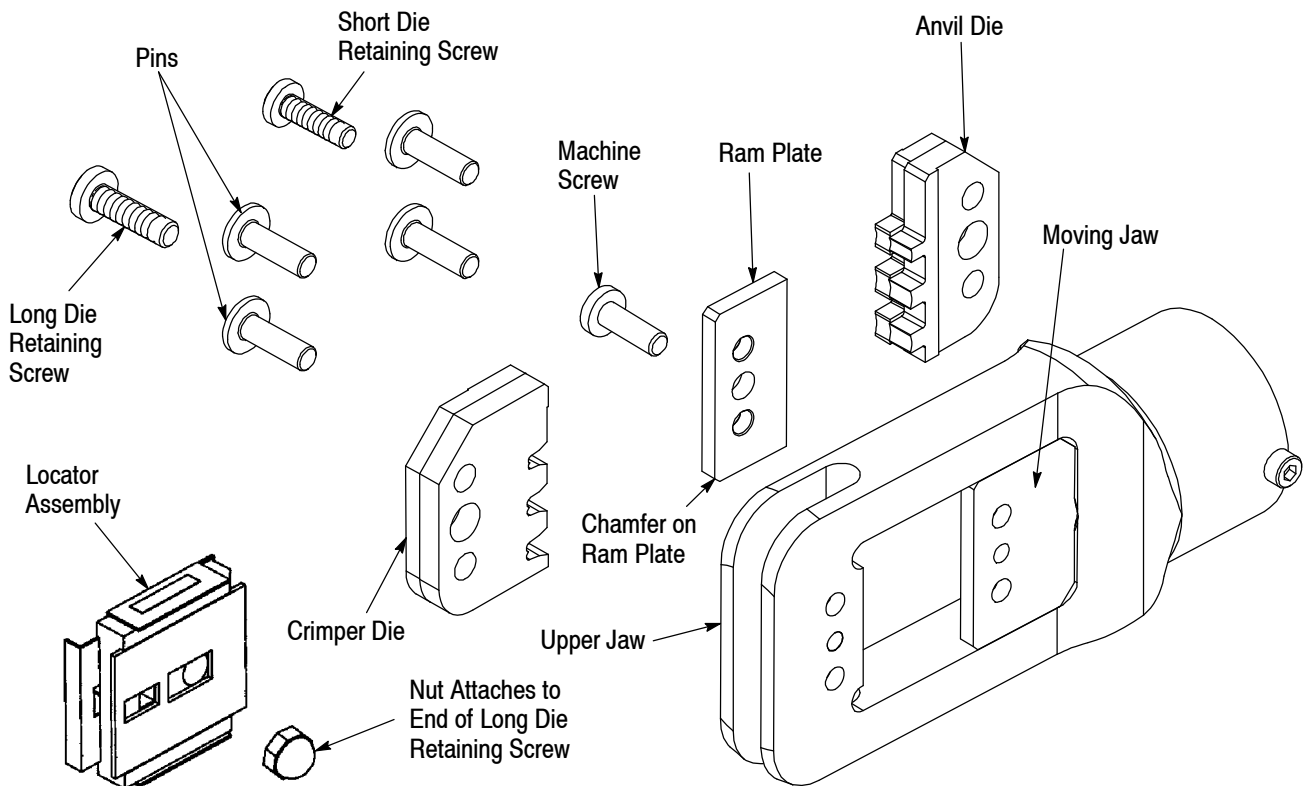

Figure 3

10. When the dies are aligned, fully tighten the die retaining screws.
11. Install the locator assembly onto the long retaining screw and secure it with the appropriate hex nut.

3.2. Removal of Shouldered and Pinned Dies

DANGER

To avoid personal injury, remove the battery before removing dies.



To remove dies from the crimp head, remove the die retaining screws, die retaining pins, ram plate, and slide the dies out of the crimp head.

4. OPERATION

4.1. Battery Installation and Removal (Refer to Figure 1)

NOTE

The Batteries Directive 2006/66/EC introduces new requirements from September 2008 on removability of batteries from waste equipment in EU Member States. To comply with this Directive, this device is designed to allow the rechargeable battery pack to be easily removed by the end-user when it needs to be replaced.

To install the battery, slide the battery into the bottom of the crimp tool until it can go no further. There will be an audible “click” of the battery lock to indicate that the battery has been properly installed.

To remove the battery, disengage the battery lock by applying pressure on the lock toward the bottom of the tool and slide the battery away from the tool.

DANGER

Always dispose of the old battery pack in an environmentally-responsible way, in accordance with local waste regulations. Where possible, please recycle the battery cartridge. Contact your local authority for details of battery recycling locations in your area.

4.2. Crimping

The following procedure provides only general information concerning crimping. Refer to the instructions packaged with the dies for detailed information, including wire stripping dimensions and instructions for positioning terminals and splices in the dies.

To operate the SDE Battery Powered Crimp Tool 1213890-[]:

DANGER

To avoid personal injury, keep fingers clear of the crimping area.



1. Insert the terminal into the dies.
2. Depress the trigger to advance the moving jaw in order to hold the terminal in place. Do NOT deform the terminal body.
3. Place a pre-stripped wire in the barrel of the terminal.
4. Depress and hold the trigger to complete the crimp. The crimp tool returns automatically to the first position of its cycle when the crimp is complete.

NOTE

If it is necessary to retract the ram before a crimping cycle is completed, push the release switch. Pushing the release switch will result in the complete retraction of the ram. Only kits 1213890-1, -2, and -5 have a release switch.

CAUTION

This tool is not designed for continuous operation. After 100 cycles, allow the crimp tool to cool for 15 minutes.

5. PREVENTIVE MAINTENANCE

5.1. Daily Maintenance

Perform the following maintenance on a daily basis:

1. Inspect the dies for wear or damage such as cracks, gouges, or chips.
2. Inspect the tool for damage or leaks. If damage is detected, return the tool to TE for repair.
3. Clean the tool, removing accumulations of dirt and grease on the head, particularly in areas where dies are installed and terminals are crimped. Wipe the entire tool frequently with a clean, lint-free cloth.

5.2. Yearly Maintenance

Once a year, or every 10,000 cycles (whichever comes first), the SDE Closed Head Battery Powered Crimp Tool should be returned to TE for inspection.

6. SPARE PARTS

- Battery: 1725839-1
- Charger: 1725840-1 (120 V, US), 1725840-2 (220 V, EU), 1725840-3 (220 V, UK)

7. TROUBLESHOOTING (Figure 4)

Prior to beginning troubleshooting procedures, be sure the battery is operational.

1. Be sure that the battery is charged. Recheck the battery after several minutes to ensure that the battery is holding its charge.
2. Use a nonflammable contact cleaner or pencil eraser to clean the the electrical contacts on the battery and crimp tool.
3. Reinstall the battery and check the crimp tool again.

PROBLEM	PROBABLE CAUSE	REMEDY
Tool is inoperative.	Dirt, contaminants, etc, in ram area of tool.	Return tool to TE.
	Crimp tool battery contacts damaged.	Reform the contacts.
	Tool components are worn or damaged.	Return tool to TE.
Dies stop during operation.	Oil level is low.	Return tool to TE.
	Air in the hydraulic system.	Pull the trigger and hold the retract button simultaneously. Hold for approximately 10 seconds.
Crimp tool loses oil.	Damaged internal seal.	Return tool to TE.

Figure 4

8. RETURN

Order replacement parts through your TE Representative, or call 1.800.526.5142; or send a facsimile of your purchase order to 1.717.986.7605; or write to:

CUSTOMER SERVICE (38-35)
 TYCO ELECTRONICS CORPORATION
 PO BOX 3608
 HARRISBURG PA 17105-3608

9. REVISION SUMMARY

Revisions to this customer manual include:

- Updated document to corporate requirements
- Added text to Section 4, OPERATION