

PROPER USE GUIDELINES

Cumulative Trauma Disorders can result from the prolonged use of manually powered hand tools. Hand tools are intended for occasional use and low volume applications. A wide selection of powered application equipment for extended-use, production operations is available.

Connector-Specific Kit 768347-1

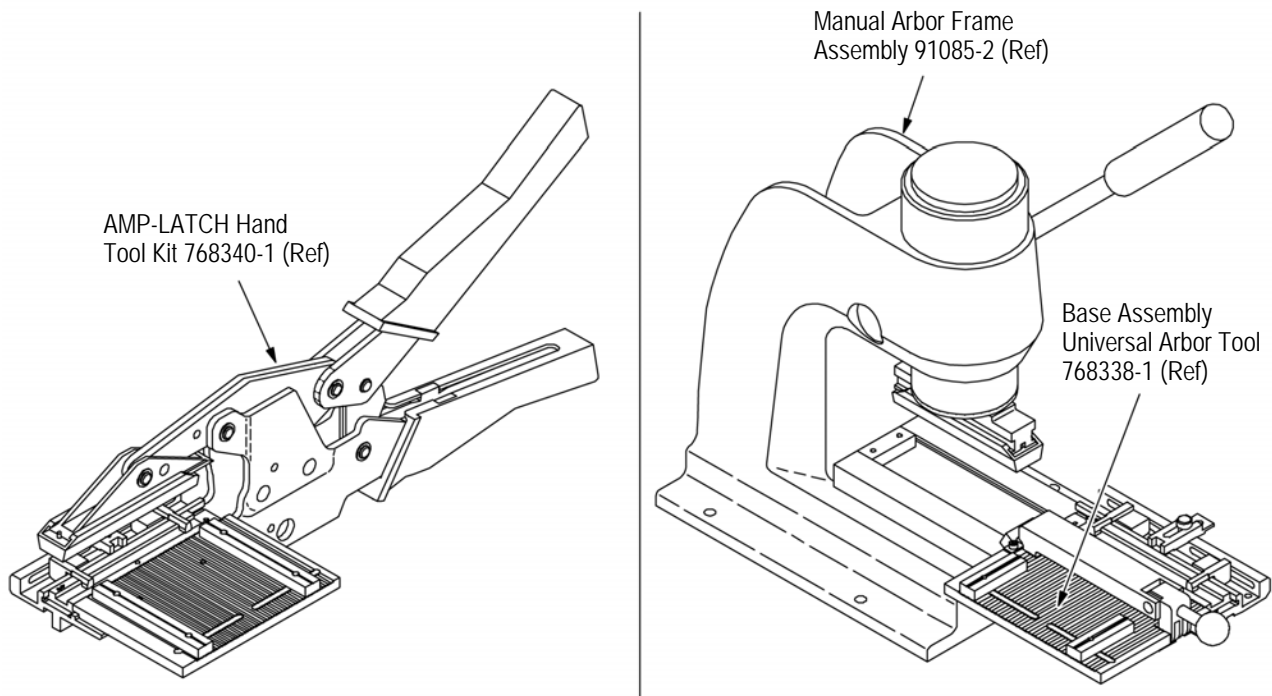
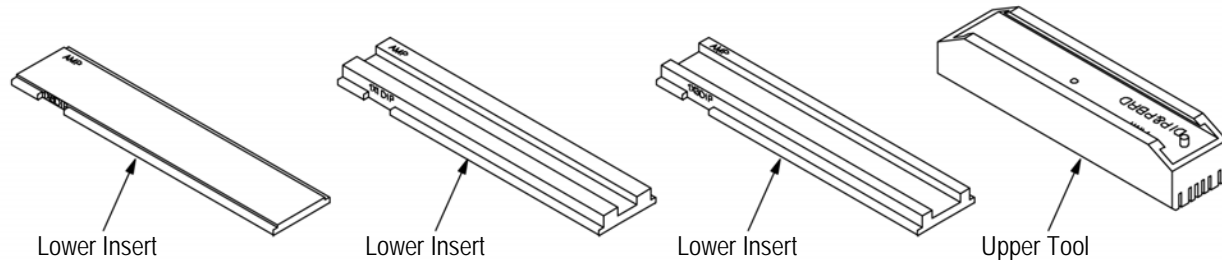

Figure 1

1. INTRODUCTION

This instruction sheet describes Connector-Specific Kit 768347-1, lists cable requirements, and describes installation of the connector-specific kit. (See Figure 1.)

The connector-specific kit is used with Base Assembly Universal Arbor Tool 768338-1 or AMP-LATCH Hand Tool Kit 768340-1 (Figure 1) to terminate AMP-LATCH

DIP Connectors to ribbon cable with 1.27 mm [.050-in.] centerline spacing. See Figure 2.

The Base Assembly Universal Arbor Tool is powered by either Manual Arbor Frame Assembly 91085-2 or Pneumatic Frame Assembly 91112-3.

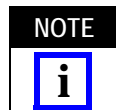

For information concerning AMP-LATCH DIP Connectors, refer to Catalog 82012. For detailed information on other tooling components used with Connector-Specific Kit 768347-1, refer to the

following specifications:
 408-6732 -- Pneumatic Auto Cycle Unit 91112-3
 408-7777 -- Manual Arbor Frame Assembly
 91085-2
 408--9827 -- Base Universal Arbor Tool 768338-1
 408-9828 -- AMP-LATCH Hand Tool Kit 768340-1

Carpenter Manufacturing Co. Inc.
 Fairgrounds Drive
 Manlius, N.Y. 13207

2. DESCRIPTION (Figure 1)

The connector-specific kit features an upper tool and three lower inserts. The upper tool applies an even force over the length of the connector during termination. Each lower insert positions the connector on the tooling assembly. Each component is marked "DIP."

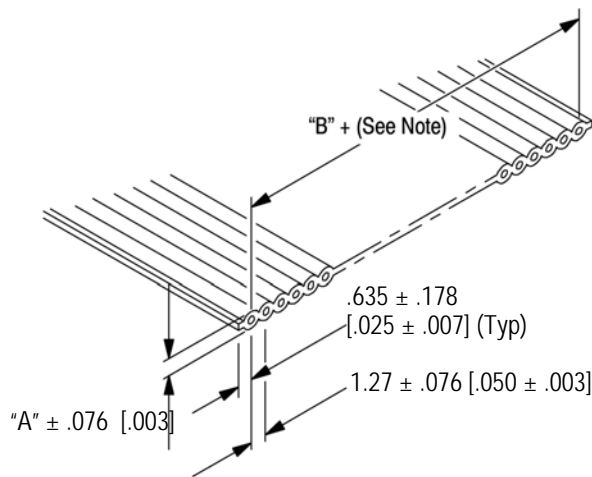

NOTE
 ACCUMULATIVE TOLERANCE FOR CABLE CONDUCTORS 1 THROUGH 34 IS + .254 [.010] AND THROUGH 60 IS + .38 [.015].

CONDUCTOR		DIMENSION	
SIZE (AWG)	TYPE	"A"	"B"
26	Stranded or Solid	0.889 mm [.035 In.]	1.27 mm [.050 In.] X (Total No. of Conductors Minus One)
28	Stranded or Solid		
30	Solid		

Figure 2

3. CABLE REQUIREMENTS

The connector-specific kit will terminate AMP-LATCH DIP Connectors with 1.27 mm [.050-in.] centerline spacing to ribbon cable with No. 26 AWG solid or stranded conductors, No. 28 AWG solid or stranded conductors, or No. 30 AWG solid conductors. Refer to Figure 2 for the recommended cable dimensions.



The cable must be cut 90° to the edge of the cable; otherwise an improper termination will result. We suggest you use a guillotine-type cable cutter, such as the Carpenter Model 95, which can be purchased from;

4. CONNECTOR-SPECIFIC KIT INSTALLATION
 (Figure 3 and Figure 4)

1. Slide the upper tool onto the upper tool mount.
2. Select the lower insert, according to the style connector being terminated, and slide the insert into the slot of the fluted plate.

This completes the installation procedure.

AMP-LATCH Hand Tool Kit 768340-1 (Ref)
 Includes AMP-LATCH Hand Tool Subassembly 76942-1 and Base Assembly Universal Hand Tool 768339-1. Refer to 408-9846 and 408-9826.)

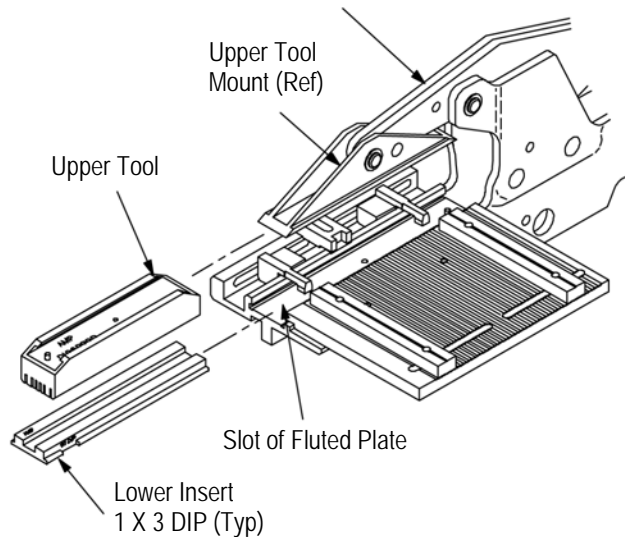

Figure 3

Base Assembly Universal Arbor Tool 768338-1 (Ref)

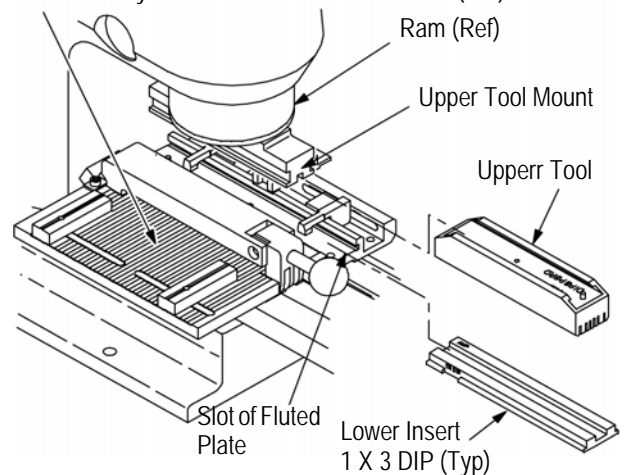

Figure 4

5. CONNECTOR-SPECIFIC KIT INSPECTION

Connector-Specific Kit 768347-1 has been inspected and should be verified with the information provided in Figure 5. It is recommended that the connector-specific kit be inspected immediately upon its arrival at your facility (and at regularly scheduled intervals) to ensure that the kit components have not been damaged during handling.

For additional information concerning connector-specific kits, contact your local TE representative or:

CUSTOMER SERVICE (038-035)
 TYCO ELECTRONICS CORPORATION
 PO BOX 3608
 HARRISBURG PA 17105-3608

6. REVISION SUMMARY

Since the previous release of this instruction sheet, the new company logo has been applied.

Connector-Specific Kit 768347-1

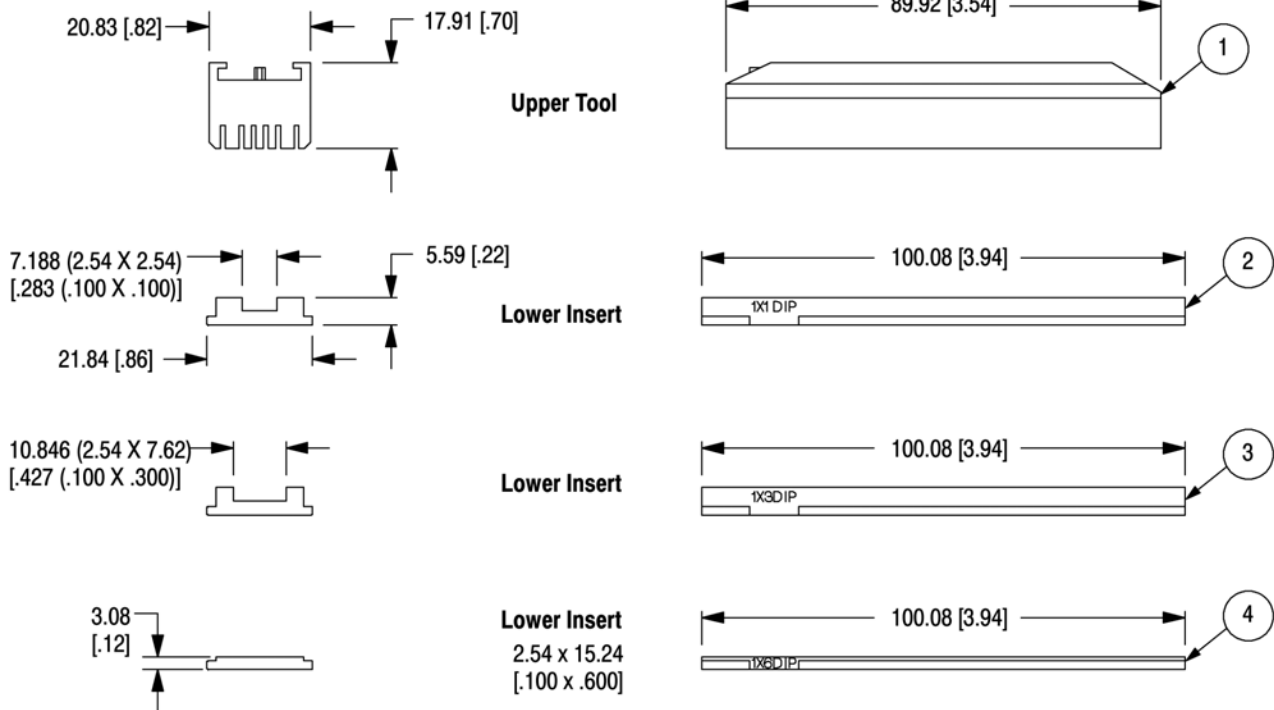

COMPONENT LIST

ITEM NO	PART NUMBER	DESCRIPTION	QTY
1	543274-5	Upper Tool	1
2	543275-5	Lower Insert	1
3	543275-6	Lower Insert	1
4	543275-7	Lower Insert	1

Figure 5