

AMPAMP INCORPORATED
HARRISBURG, PA 17105CUSTOMER HOTLINE
1 800 722-1111INSERTION TOOL 314919-1
FOR AMP* ULTRA-POD FLAG FULLY
INSULATED FASTON* RECEPTACLES

REDUCED FOR PACKAGING

IS 9727RELEASED
7-23-91

Fig. 1

cad

1. INTRODUCTION

AMP Insertion Tool 314919-1 is used to insert FASTON .250 Series Flag Receptacles into Ultra-Pod Flag Fully Insulated Housings. Read these instructions thoroughly before inserting any contacts. See Figure 1.

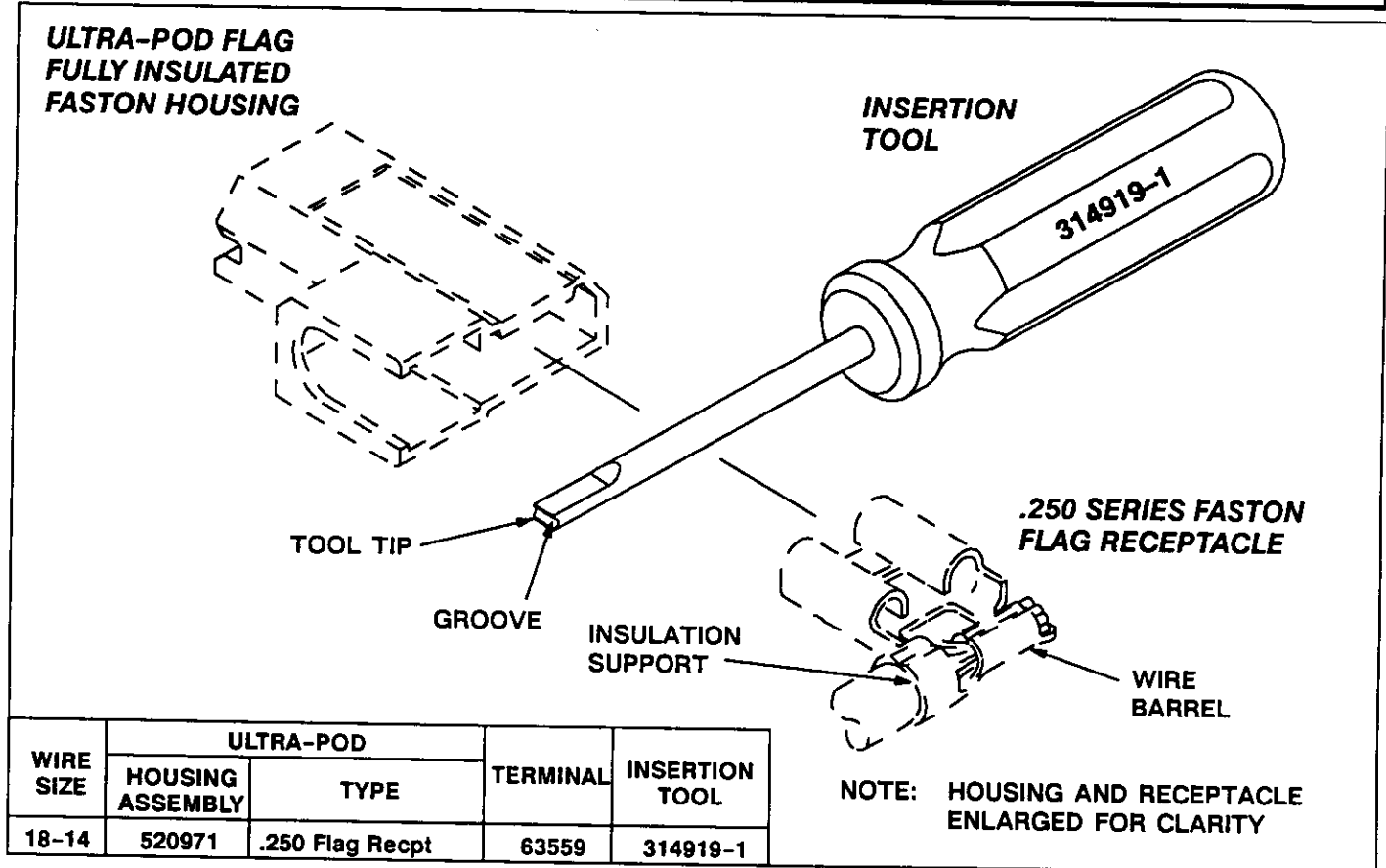
NOTE

All dimensions on this sheet are in inches.

2. DESCRIPTION

The tool tip features a groove to fit against the back of the contact; the tool handle assists in applying even pressure during the entire procedure.

3. INSERTION PROCEDURE (See Figure 2)

Insert the contact as follows:

1. Start the contact and its attached wire into the selected housing cavity using your fingers.
2. With one hand holding the housing, and the other hand holding the tool, place the tip of the tool against the back of the contact (wire barrel).
3. Slowly and steadily push the partially inserted contact into the cavity.
4. Push the contact into the cavity until it meets the plastic retention feature inside the pod; with an additional push, the contact will go under the retention feature and bottom in the cavity. Withdraw the tool.
5. Ensure the insertion is correct by pulling lightly on the contact wire to make certain that the contact is locked in place.

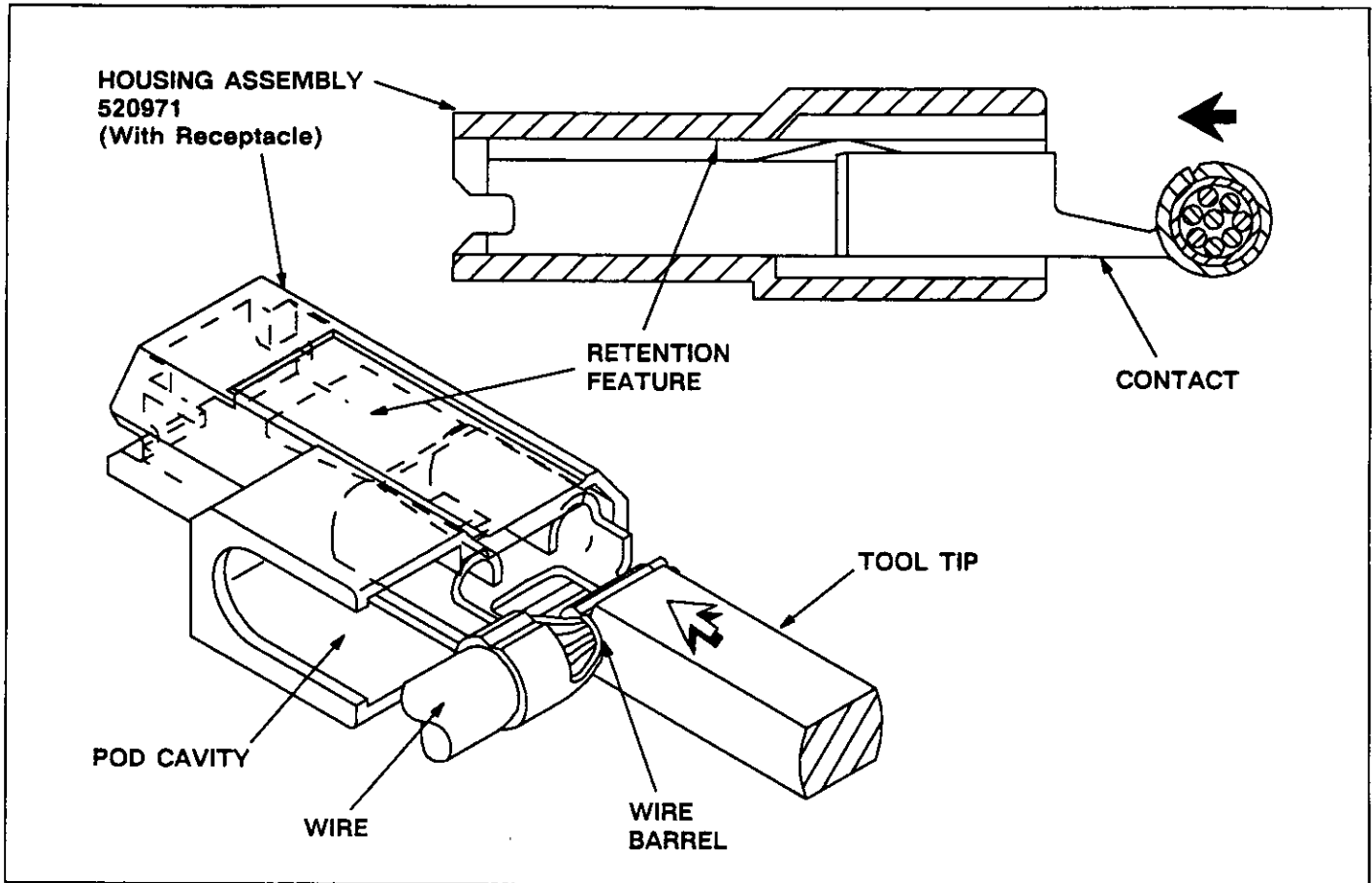

Fig. 2

cad

4. MAINTENANCE AND INSPECTION

To ensure proper operation, the tool should conform to the dimensions provided in Figure 3. It is recommended that the tool be inspected immediately on its arrival and at regularly scheduled intervals. The tool is not repairable and should be replaced when worn or damaged. It is recommended that the tool be stored in

a clean, dry place and cleaned with a soft, lint-free cloth.

Additional tools can be purchased from:

CUSTOMER SERVICE (38-35)
 AMP INCORPORATED
 P. O. BOX 3608
 HARRISBURG, PA 17105-3608

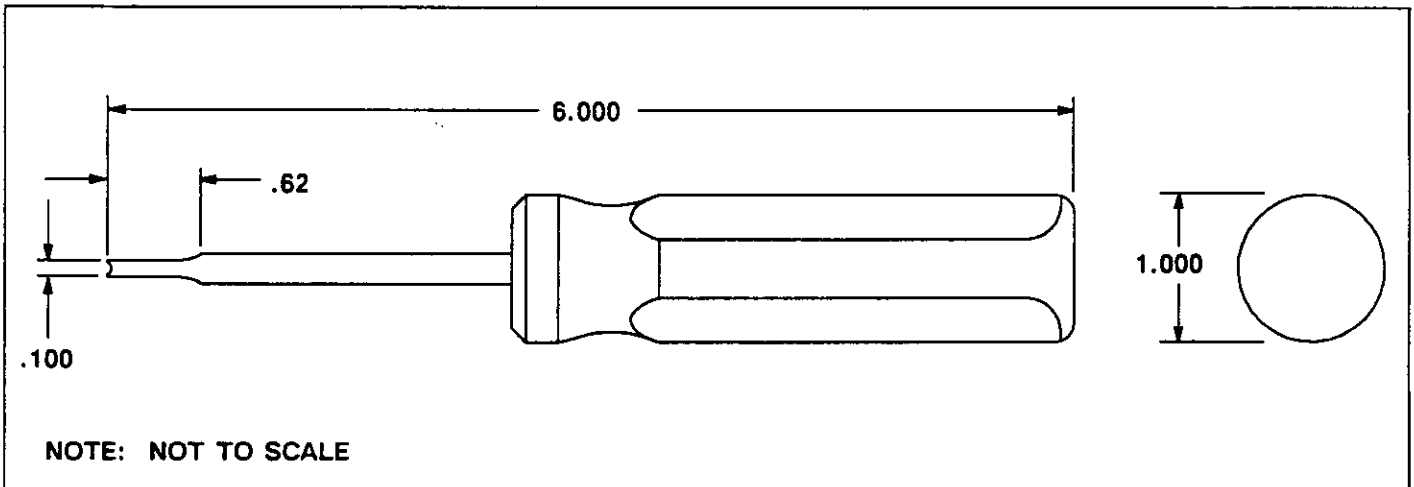

Fig. 3

cad