

Figure 1

### 1. INTRODUCTION

This instruction sheet covers assembly of the AMP\* Coaxial Series F Plug Connectors shown in Figure 1. Read these instructions carefully before assembling the connectors.

**NOTE**

All dimensions are in millimeters [with inches in brackets].

Reasons for reissue are provided in Section 4, REVISION SUMMARY.

### 2. DESCRIPTION (Figure 1)

Series F plug connectors are available in three different types: Connector 414766 features a long attached outer ferrule; Connector 221539 features a short attached outer ferrule; and Connector 221540 features a threaded assembly.

### 3. ASSEMBLY PROCEDURE

Refer to the stripping dimensions shown in Figure 2 for the three types of connectors. Strip the cable as required, and proceed as follows:

#### 3.1. Connector 414766 (Figure 3)

1. Fold braid back over cable jacket.
2. Slide connector onto stripped cable, making sure that the cable dielectric passes inside the plug body while the cable jacket and braid slide over the inner ferrule.

#### Cable Stripping Dimensions

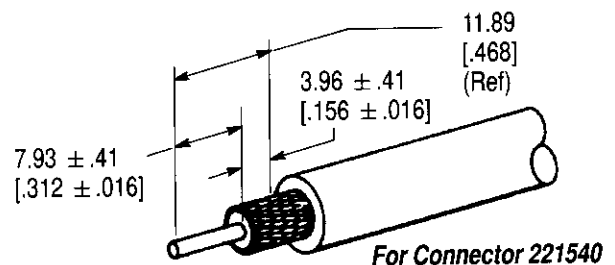
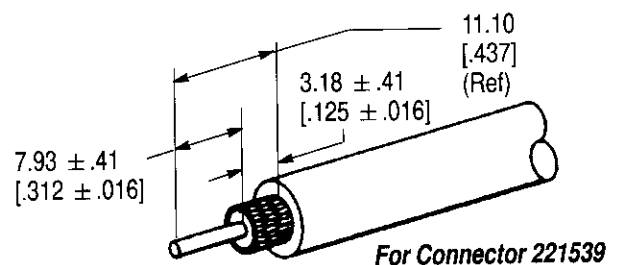
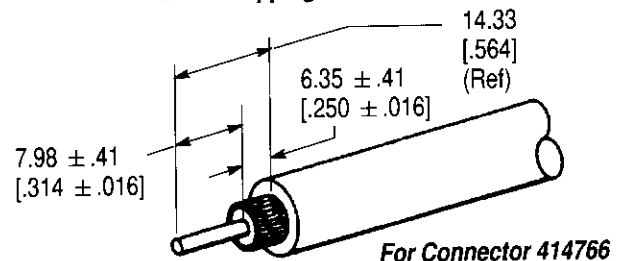

Figure 2

**Connector 414766**

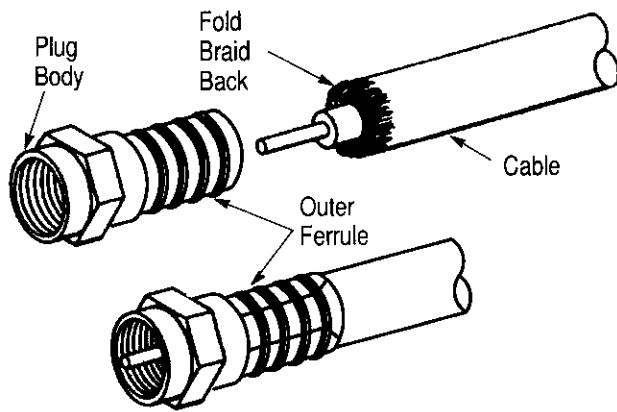

Figure 3

**Connector 221539**

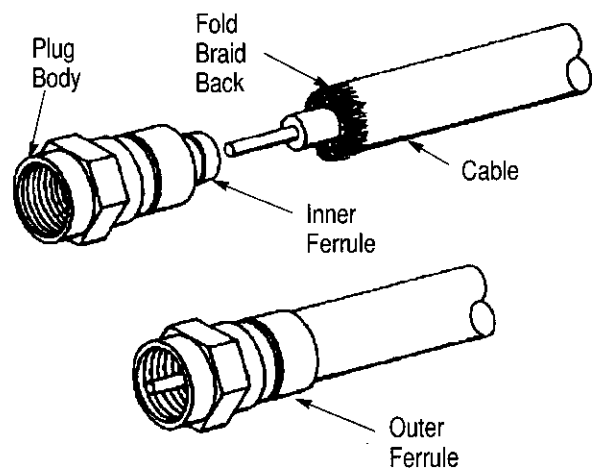

Figure 4

3. Bottom the cable jacket against shoulder of plug body.

4. Crimp the outer ferrule using AMP PRO-CRIMPER<sup>®</sup> II hand tool (58621-1) which includes a .324 hex die set (58621-2).

**3.2. Connector 221539** (Figure 4)

1. Fold braid back over cable jacket.
2. Slide connector onto stripped cable, making sure the cable dielectric passes inside plug body while the cable jacket and braid slide over the inner ferrule or ribbed portion of plug body.
3. Bottom the cable jacket against shoulder of plug body.
4. Crimp the outer ferrule using AMP PRO-CRIMPER II hand tool (58621-1) which includes a .324 hex die set (58621-2).

**3.3. Connector 221540** (Figure 5)

1. Fold braid back over cable jacket.
2. Push the stripped cable into the opening in the rear of connector which contains internal threads.
3. Press and turn the connector in a **CLOCKWISE** direction while holding the cable stationary.

**NOTE**

*While pressing and turning the connector, keep it properly aligned with respect to the cable.*

4. Keep turning the connector until the center conductor of the cable protrudes past the end of the connector coupling nut approximately 3.18 mm [.125 in.].

**Connector 221540**

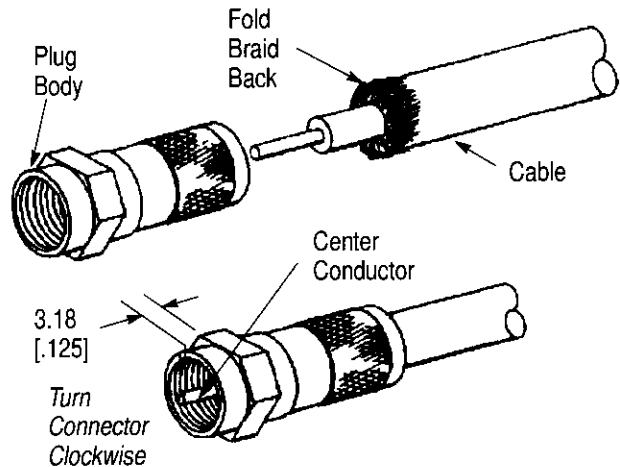

Figure 5

**4. REVISION SUMMARY**

Since the previous release, the following changes were made to this document:

Per EC 0990-0193-96:

- Deleted information for obsolete connector 221536 and added information for new connector 414766 in Figures 1, 2, and 3.