

TYPE	POSITIONS	CONNECTOR PART NO.	POST LENGTH	
Without Card Scoops	15, 30, 33, 50	119485	.180	
	32	645114		
	50	119530		
	Without Card Scoops, Open End/Closed End	15 thru 61	119215	.475
		15 thru 61	119216	
		30, 50	119384	
		50	119535	
		15, 18, 20, 22, 25, 28, 30, 31, 35, 36, 37, 40, 43, 50, 55, 60	119738	
		30	119800	
		50	119881	
		15 thru 61	119163	
		15 thru 61	119214	
		55	119493	
	Without Card Scoops, Open End/Closed End	40, 50	119497	.702
		40	119574	
		40	119621	
		30, 40, 60	119677	
		35	119783	
		43	119812	
		60	645110	
35		119478		
35		119922		
5, 30 thru 61		119379		
With Card Scoops	30 thru 60	119469	.475	
	35	119553		
	30, 32, 35, 55, 60	119830		
	30 thru 60	119467		
	30 thru 60	119468		
	33, 40, 41	119560		
	35	119676		
	50	119837		
	15, 18, 22, 25, 28, 30, 35, 36, 37, 40, 43, 50, 55, 60	119725		
	15, 18, 22, 25, 28, 30, 35, 36, 37, 40, 43, 50, 55, 60	119791		
With Card Scoops, Open End/Closed End	15, 18, 22, 25, 28, 30, 35, 36, 40, 43, 50, 55, 60	119726	.702	
	30, 35, 60	119827	.475	
		119828	.475	
		119829	.702	

TYPE CONNECTOR	TOOLING				
	APPLICATION		CONTACT REPLACEMENT		
	MANUAL	MACHINE	REMOVAL	INSERTION	COMBINED
Without Card Scoops	59942	59952	1-265871-7	266220-1	266227-1
	58140	58144		266220-1	266227-1
With Card Scoops	58150	59180		--	--

Fig. 1

Copyright 1985 by AMP Incorporated, Harrisburg, PA. All International Rights Reserved. AMP Incorporated products covered by U.S. and Foreign patents and/or patents pending.

1. INTRODUCTION

This instruction sheet (IS) provides assembly information for AMP PACE connectors on .100- x .200-in. centerlines, and describes their accessories and application, insertion, and repair tooling (see Figure 1).

NOTE All dimensions presented are in inches, unless otherwise indicated.

2. DESCRIPTION

Each AMP PACE connector includes: AMP★ ACTION PIN contacts (current-rated at 3A) with .025-in.-square posts for mass insertion into .093-in.-thk (nom) double-sided or multilayered boards; a housing; and a pre-inserted clear plastic alignment strip that helps to align the contact posts with the board holes prior to insertion. During board insertion, the plastic strip moves up over the posts and finally nests between housing and board surface. It is not removed after assembly.

Each blue or black housing is made of glass-filled thermoplastic polyester, and is UL-rated at 94V-O. The chamfered edges of the housing permit entry of a .054- to .071-in.-thk board without damage to contacts or board pads. Typical card slot depth is .415 in.

NOTE Housings do not need to be removed for contact replacement.

One end of a connector may be "open" to pair with the "open" end of another connector, allowing for insertion of longer-than-usual daughterboards. Some connector ends are dovetailed to accept card guides (see Figure 2) that mount to the pc board. Along with

card guides, connectors with full or partial card scoops are available; both types of locational devices facilitate insertion of the daughterboard into the connector.

3. ACCESSORIES (Figure 2)

Accessories for AMP PACE connectors include card guides, power distribution modules, ground modules, contact repair combs, and keying plugs.

NOTE Connectors with heights of more than .545 in. do not accept power modules.

Card Guides are available in several lengths. Refer to Figure 2.

Power Distribution Module, Part No. 119337, is a card edge connector that is inserted into a bus bar and is also plugged onto the end of an AMP PACE connector, transferring power from bus bar to daughtercard. The power distribution module has a current rating of 20A per contact, and it can be used for either power or ground.

Ground Module, Part No. 119341, is a free-standing card edge connector plugged into a bus bar. The ground module has a current rating of 20A per contact and can be used for either power or ground.

Contact Repair Comb, Part No. 119715, (not shown in Figure 2) is a strip of replacement contacts used to replace faulty contacts in pc board-inserted AMP PACE connectors.

Keying Plugs, Part No. 118982-1 (plastic) and Part No. 119129-2 (metal), are used on connectors to aid in orientation and to prevent mismatching. (See Figure 1.)

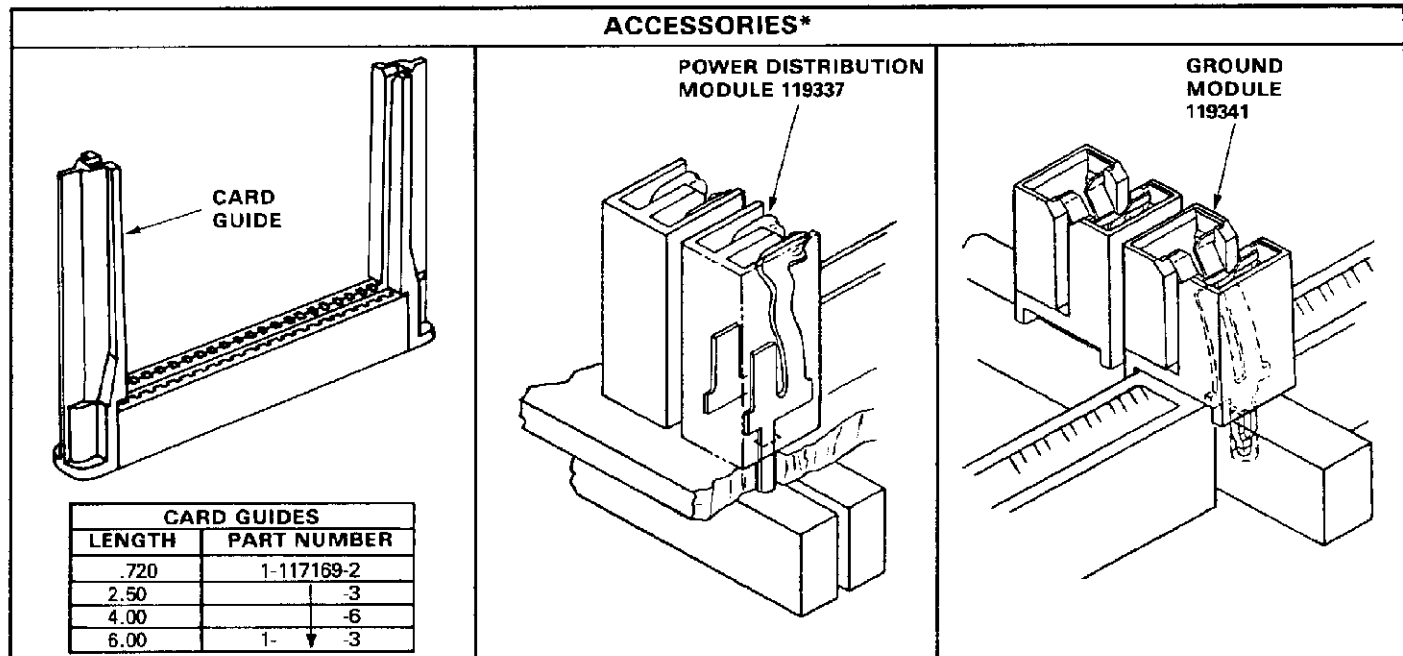

* CONTACT REPAIR COMBS AND KEYING PLUGS NOT SHOWN.

Fig. 2

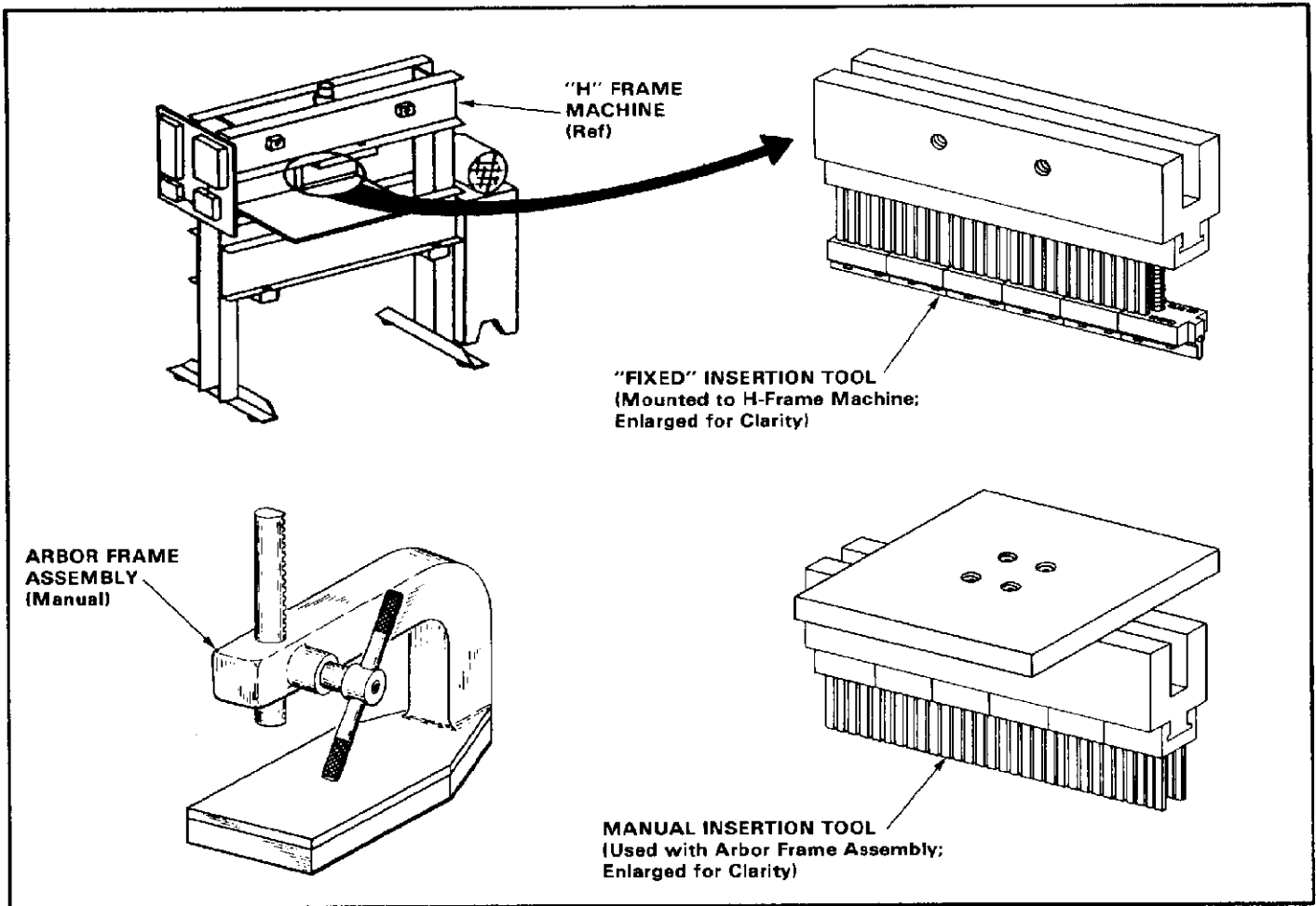

Fig. 3

4. APPLICATION TOOLING (Figures 1 and 3)

AMP PACE connectors can be inserted into pc boards by using insertion tooling and a hand-operated press; eg, an arbor frame unit; or by using insertion tooling mounted to an automatic unit; eg, a hydraulic H-frame machine that is part of a fixed insertion system. Either type of unit must be capable of applying an insertion force of 50 lb per contact post (max) at a pre-determined shut-height.

Refer to Figure 1 for tooling numbers, and to Figure 3 for illustrations.

A. Fixed Insertion System

Besides the AMP H-Frame Machine, the fixed insertion system also includes: a pc board fixture assembly, made up of a pc board template; a straight-edge bar and detent subassembly; and an indexing rack. See Application Specification 114-26002 for details on the fixed insertion system for automatic insertion of AMP PACE connectors, or consult AMP Engineering, Wiring Products Division.

B. Shut-Height

Ram shut-height — the distance between the bottom surface of the ram and the top surface of the pc board when the ram is fully bottomed — must be adjusted, if necessary, to the dimension specified on the instruction sheet packaged with the insertion tool.

Refer to the instructions packaged with the insertion tooling for information on tooling installation, insertion procedure, and tooling maintenance.

5. HOLE SPECIFICATIONS

Refer to Figure 4 for recommended pc board hole specifications.

ACTION PIN CONTACT HOLE SIZE SPECIFICATIONS	
Required Drill Size:	.0453
Copper (Cu) Plating Thickness:	.001 to .003
Cu Plating Hardness:	150 Knoop (Max)
Tin/Lead Thickness:	.0003 (Min)
Finished Hole Size:	.037 to .043
Board Thickness (Min, Max):	.084, .125
Pad Hole Dia (Min):	.062

Fig. 4

6. DAUGHTERCARD LAYOUT

Refer to Figure 5 for recommended dimensions for finger patterns and spacing on daughtercard.

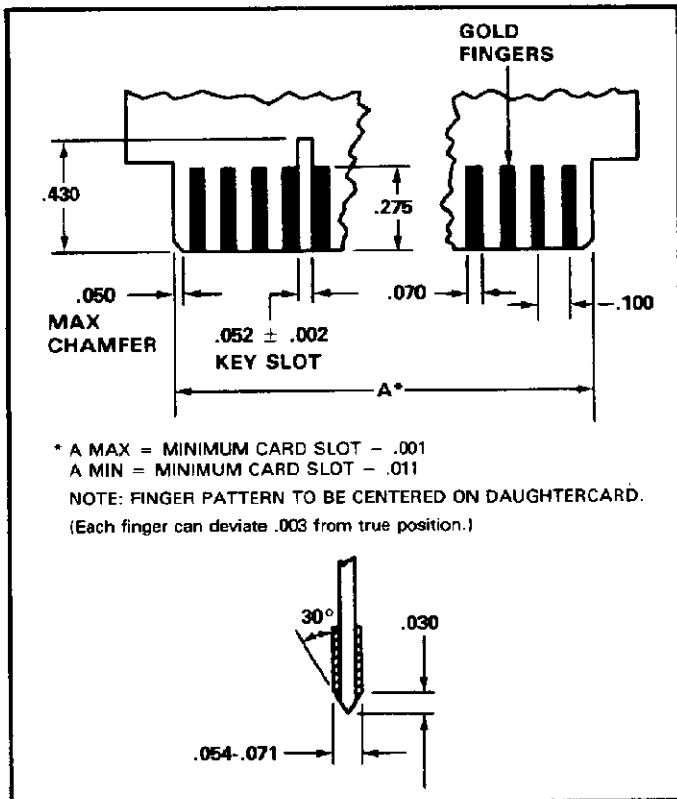

Fig. 5

7. QUALITY CHECK (Figure 6)

Inspect the AMP PACE connector after it has been inserted into the pc board according to the following criteria:

1. Preloaded tabs of contacts are against preload barrier.

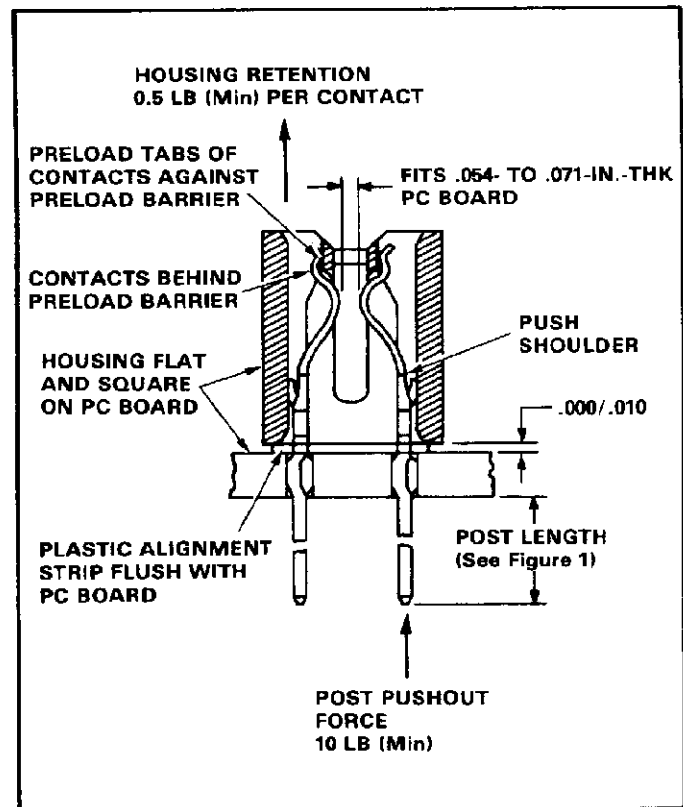

Fig. 6

2. Contacts are behind preload barrier.
3. Housing is flat and square on pc board.
4. Plastic alignment strip is flush with pc board.
5. Post height is dimension referenced in Figure 1.
6. Refer to Product Specification 108-14019 for more details on inspecting AMP PACE connectors.