

CONNECTOR	RG/U CABLE	DIES ASSEMBLY (DOCUMENT)	HAND TOOL (DOCUMENT)
221199-1 5221199-1	BELDEN 9248	58086-1 (408-6877)	1213745-1 (N/A)
			1490076-2 (409-10052)
			1583034-1, -2 (N/A)
		58536-1 (408-4028)	354940-1 (408-9930)
			1213745-1 (N/A)
			9-1478240-0 (408-8851)
			1583034-1, -2 (N/A)
			1725837-1 (409-10053)
221199-5	RG 179	318451-2 (408-4217)	354940-1 (408-9930)
			1213745-1 (N/A)
			1213855-1 (N/A)
			1213890-1, -2 (409-10065)
			9-1478240-0 (408-8851)
			1490076-2 (409-10052)
			1583034-1, -2 (N/A)
413760-3	BELDEN 8218	58174-1 (408-6877)	58248-3 (408-9261)
		---	58531-2 (N/A)
		58425-2 (408-9657)	354940-1 (408-9930)
			1213745-1 (N/A)
			1213855-1 (N/A)
			9-1478240-0 (408-8851)
			1490076-2 (409-10052)
			1583034-1, -2 (N/A)
1725837-1 (409-10053)			
5221199-2	59, 59A, 59B	58085-1 (408-6877)	58248-2 (408-9261)

Figure 1

## 1. INTRODUCTION

This instruction sheet covers the selection and assembly of the 75-Ohm RF Series BNC Coaxial Jack Connectors listed in Figure 1. Read these instructions thoroughly before starting assembly.

### NOTE



All dimensions on this document are in metric units [with U.S. customary units in brackets]. Figures and illustrations are for reference only and are not drawn to scale.

Reasons for reissue of this document are provided in Section 6, REVISION SUMMARY.

**2. DESCRIPTION**

Each connector features a center contact, a jack body, and a ferrule. Refer to the table in Figure 1 for cable type, connector part numbers, and tooling used to crimp connectors onto cable. Refer to Figure 2 for cable stripping dimensions.

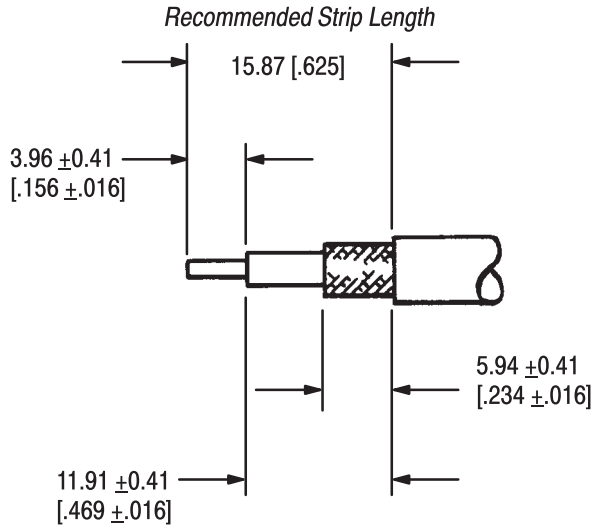

**NOTE:** Do NOT Scale from Drawing

Figure 2

**3. ASSEMBLY** (Figure 3)

Determine cable requirement and then refer to table in Figure 1 to select appropriate connector for application. Proceed as follows:

1. Slide ferrule onto cable and then strip cable according to dimensions provided in Figure 2.
2. Crimp center contact onto cable using tooling referenced in Figure 1.



*Jack Connector 221199-5 comes with a plastic bushing and a brass tube. The bushing and tube must be slipped over the cable dielectric (flared end first) before the center contact is crimped onto the cable.*

3. Insert the crimped center contact into the jack body, with the braid over the support sleeve of the jack body, until the contact snaps into place. Pull back gently on cable to ensure that contact is held in place by its internal latch.
4. Slide ferrule forward over braid and support sleeve of connector.
5. Crimp ferrule onto connector and cable using appropriate tooling referenced in Figure 1.

**4. REVISION SUMMARY**

- Updated document to corporate requirements
- New format
- Deleted obsolete part numbers in table in Figure 1
- Added new tooling to table in Figure 1

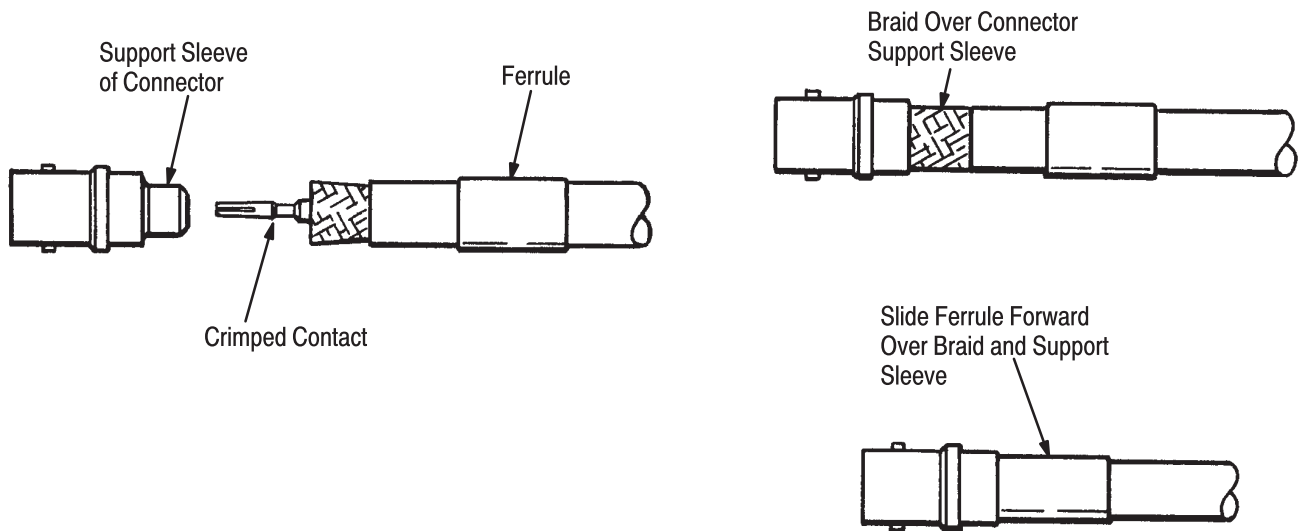

Figure 3