

Figure 1

1. INTRODUCTION

CPC Series 45 Shielded Receptacle Kit 1546908-1 is designed for use in harsh environments. The receptacle engages with CPC shielded or unshielded plugs.

This receptacle kit is designed for front or rear panel-mount applications.

NOTE



Instruction Sheet 408-8951 provides assembly and engagement instructions for the plug.

NOTE



Dimensions in this instruction sheet are in metric units [with U.S. customary units in brackets]. Figures are not drawn to scale.

Reasons for reissue of this instruction sheet are provided in Section 5, REVISION SUMMARY.

2. DESCRIPTION

The receptacle kit consists of the components shown in Figure 1.

3. ASSEMBLY

1. Terminate the SL 110 jack, and assemble the shield onto the SL 110 jack according to Instruction Sheet 408-8602.
2. Align the locking tab of the SL 110 jack (mating face first) with the wide slot at the back (large

diameter end) of the receptacle assembly. Depress the locking tab, and insert the SL 110 jack into the receptacle assembly until there is an audible "click." Gently pull the cable to ensure that the SL 110 jack is fully seated. See Figure 2, Detail A.

CAUTION



To avoid damage to the connection, the cable must be pulled GENTLY when seating the jack.

3. Fit the flange seal over the mating face (small diameter end) of the receptacle assembly (for back panel mount) or the back of the receptacle assembly (for front panel mount) until it is flat against the flange. Make sure that the mounting holes align. See Figure 2, Detail B.

Assembling Receptacle Kit

Detail A

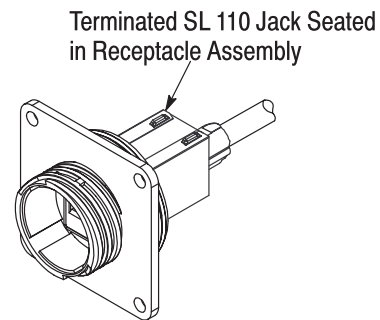

Detail B

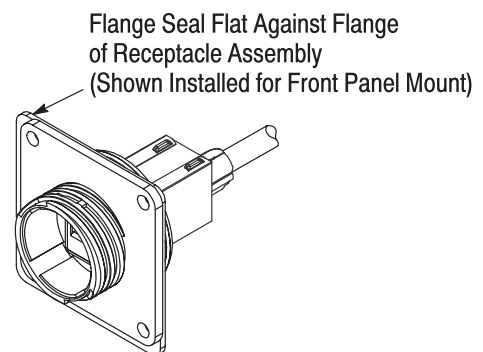

Figure 2

4. Cut the panel using the dimensions provided in Figure 3.
5. Insert the receptacle assembly into the panel until the flange seal is flat against the panel. See Figure 4.
6. Thread four No. 4 screws into the mounting holes, and tighten until secure.

Recommended Panel Cutout

Maximum Panel Thickness: 3.18 mm [.125 in.]

Note: Not to Scale

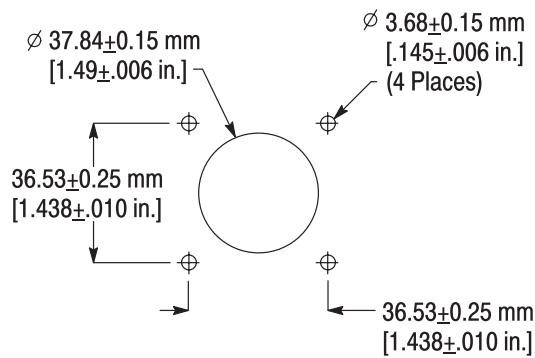

Figure 3

Panel Mounting

Note: Front Panel Mount Shown

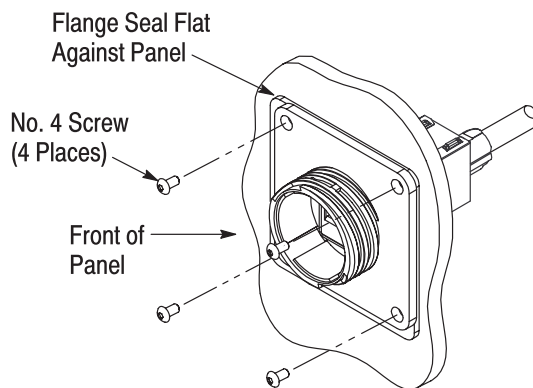

Figure 4

4. REPLACEMENT AND REPAIR

Components of the receptacle kit are not repairable. DO NOT use defective or damaged components.

DO NOT re-use the SL 110 jack assembly by removing the cable.

5. REVISION SUMMARY

Revisions to this instruction sheet include:

- Updated document to corporate requirements