

Figure 1

1. INTRODUCTION

The Industrial Circular Ethernet panel-mount connector system consists of a plug connector and a receptacle connector. Each connector is supplied as a kit (part numbers are given in Figure 1).

A protective cover assembly is available for each connector to prevent contamination when the connectors are not engaged.

The connector system is designed for front or rear panel-mount applications.

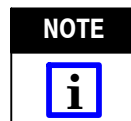

All numerical values in this instruction sheet are in metric units [with U.S. customary units in brackets]. Figures are not drawn to scale.

Reasons for reissue of this instruction sheet are provided in Section 6, REVISION SUMMARY.

2. DESCRIPTION

Each plug kit and receptacle kit consist of the components shown in Figure 1.

3. ASSEMBLY

3.1. Plug Kit

1. Install the plug assembly (strain relief end first) onto the cable. Then, using Industrial Ethernet Strip Tool 1981944-1, strip the cable jacket to the dimension given in Figure 2.

For IDC contacts only, strip the cable braid to the dimension given in Figure 2.

DO NOT cut or remove the insulation of individual conductors; otherwise, shorted or open terminations could result.

NOTE *Application Specification 114-13136 contains detailed cable selection requirements.*

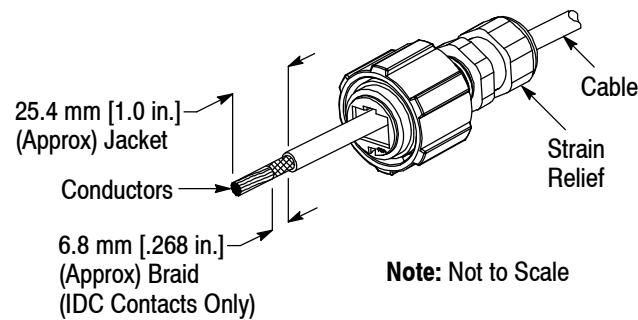

Figure 2

2. Arrange the conductors as follows:

a. Orient the conductor pairs side-by-side in the order shown in Figure 3, Detail A. Flatten the end of the cable jacket so that the conductor pairs lay side-by-side.

b. Make sure that the properly sequenced conductor pairs extend into the cable jacket to the dimension given in Figure 3, Detail B, creating an oblong shape.

c. Trim the conductor tips evenly to the dimension given in Figure 3, Detail C, making sure that proper orientation and twist of the conductors is maintained.

d. For crimp-type contacts only, untwist and arrange the conductor pairs according to EIA/TIA T568A or T568B (defined in Figure 3, Detail D). IT IS CRITICAL that the the pairs are NOT untwisted inside the cable jacket. When arranging conductor pairs, IT IS IMPORTANT that Conductor 6 be crossed over Conductors 4 and 5 as shown in Figure 3, Detail C.

Conductor Arrangement

Note: Cable Braid (Used with IDC Contacts) Not Shown

Detail A

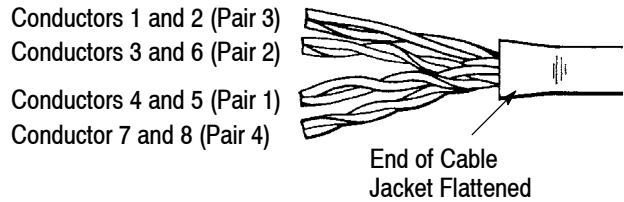

Detail B

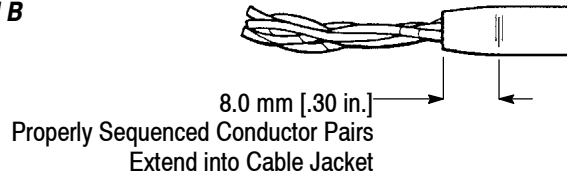

Detail C

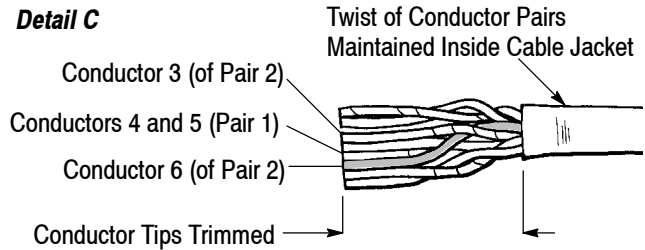

Crimp-Type Contacts (Modular Plug)	IDC Contacts (Common Core Assembly)
19 mm [.75 in.] Approx	21.8 mm [.86 in.] Approx

Detail D

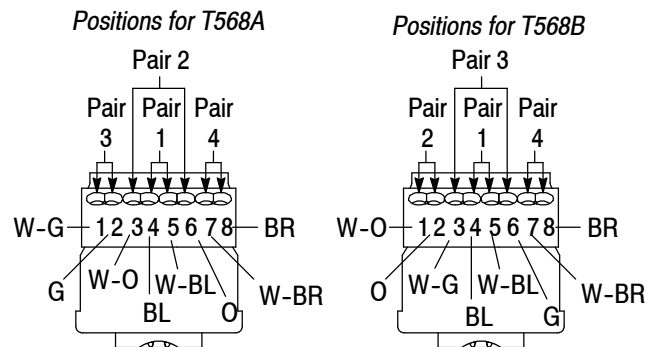

Figure 3 (Cont'd)

NOTE *The modular plug (crimp-type contacts) only has embossed numbers for contact identification.*

3. Terminate the modular plug (crimp-type contacts) or common core assembly (IDC contacts) to the cable end.

CONDUCTOR PAIR	CONDUCTOR PAIR For Electrical Schematic		CONDUCTOR COLOR CODE (Abbreviation)	
	T568A	T568B	OPTION 1	OPTION 2
1	4	4	Blue (BL)▪	Red (R)
	5	5	White-Blue (W-BL)	Green (G)
2	3	1	White-Orange (W-O)	Black (BK)
	6	2	Orange (O)	Yellow (Y)
3	1	3	White-Green (W-G)	Blue (BL)
	2	6	Green (G)▪	Orange (O)
4	7	7	White-Brown (W-BR)	Brown (BR)
	8	8	Brown (BR)▪	Slate (S)

▪ A white marking is acceptable.

Figure 3 (End)

For the modular plug, proceed as follows:

- a. Maintaining conductor arrangement, insert the conductors into the load bar (oriented so that the cable notch of the load bar will align with the contacts) until the cable jacket rests against the cable notch. Make sure that the conductor twist does not enter the front of the load bar. Trim the conductors evenly and square with the front edge of the load bar to the dimension given in Figure 4, Detail A.
- b. Retract the conductors from the load bar so that the conductors protrude from the end of the load bar to the dimension given in Figure 4, Detail B. Make sure that the top of the load bar is not deformed.

NOTE



If the load bar is deformed, the conductor twist entered the front of the load bar.

- c. Orient the load bar with the opening of the modular plug so that the cable notch is aligned with the contacts. See Figure 4, Detail C.
- d. Insert the load bar into the modular plug until it butts against the mating feature of the modular plug and the conductors are bottomed on the wire circuits. Make sure that the cable jacket is against the cable notch after the load bar is fully seated. Make sure that the conductors are not exposed between the cable jacket and cable notch and the ends of the conductors are clearly visible through the front of the modular plug. See Figure 4, Detail D.

Terminating Modular Plug

Detail A

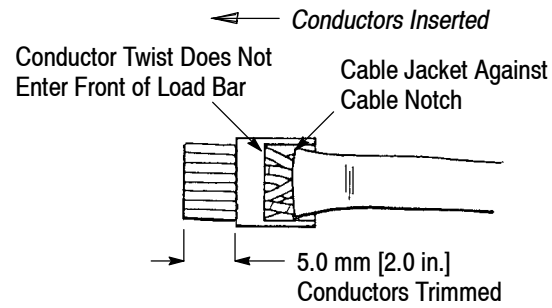

Detail B

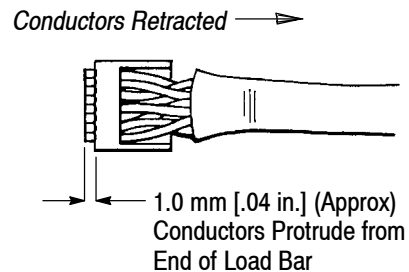

Detail C

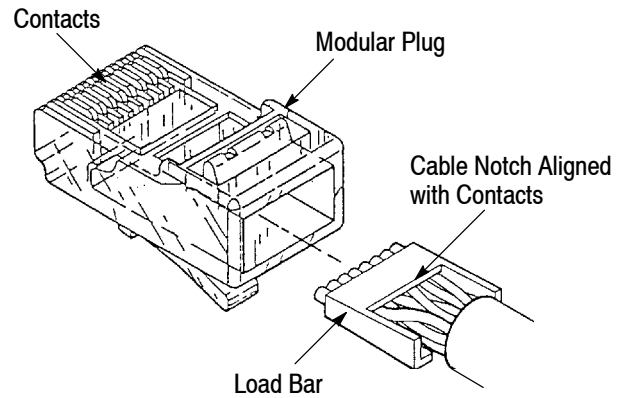

Detail D

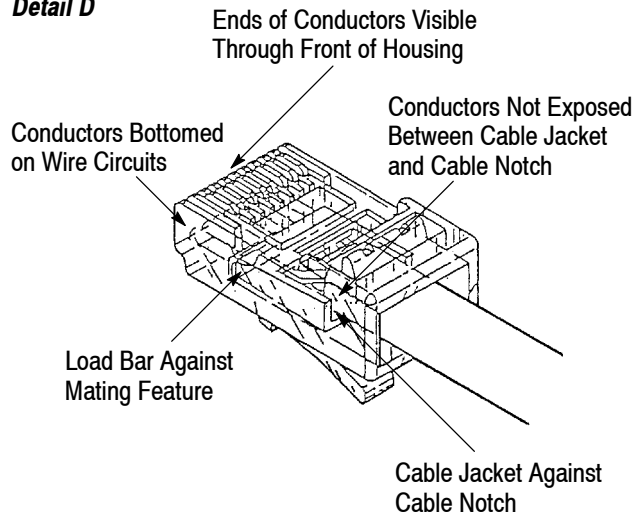

Figure 4



If the conductors do not bottom on the wire circuits, re-trim them (after removing the load bar with the cable from the modular plug), and re-insert the load bar into the modular plug. If the conductors are too short, re-strip the cable.

e. Using one of the following tools, terminate the modular plug according to the instructions included with the tool.

- Modular Plug Hand Tool 2-231652-0 and Die Set 1-853400-0
- Modular Plug Dual Terminator 1320840-1
- Terminating Module 1-856196-1
- Modular Plug Single Terminator 354711-8 and Tooling Kit 354714-7
- Modular Plug Cat6 Tool/Die 790163-9

For the common core assembly, proceed as follows:

- a. Open the top shield of the common core assembly. Make sure that the colors of the cable conductors match the colors on the color-coded label. Refer to Figure 5, Detail A.
- b. Insert the conductors (maintaining arrangement) into the conductor guide until the end of the conductors butt against the end of the housing. Make sure that the conductors are NOT twisted in the conductor guide. See Figure 5, Detail B.
- c. Close the top shield until there is no gap in the seam between top shield and the bottom shield. There will be an audible “click.” Make sure that the cable braid is located in the strain relief. See Figure 5, Detail B.

4. Align the locking tab (modular plug) or the latch (common core assembly, located at the end of the bottom shield) with the wide slot at the front (end opposite the strain relief) of the plug assembly. See Figure 6, Detail A.

5. Insert the modular plug (holding the locking tab down) or common core assembly into the plug assembly. Gently pull the cable until the modular plug or common core assembly is fully seated. There should be approximately 12.7 mm [.50 in.] of the modular plug or common core assembly protruding from the front of the plug assembly. See Figure 6, Detail B.



To avoid damage to the connection, the cable must be pulled GENTLY when seating the modular plug or common core assembly.

6. While holding the modular plug or common core assembly in position and using a torque tool, rotate the strain relief as shown in Figure 6, Detail B, until tightened within the torque given in Figure 6.

Terminating Common Core Assembly

Detail A

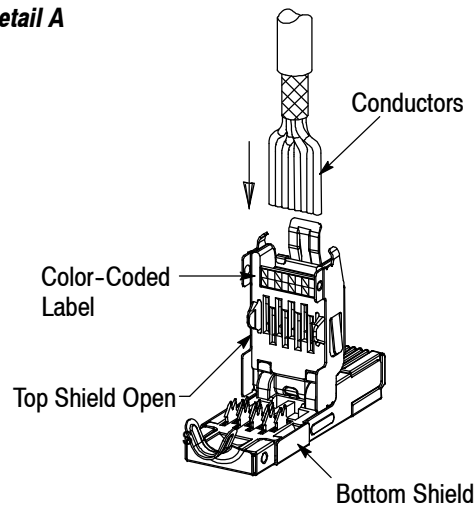

Detail B

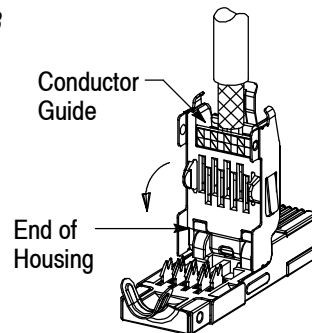

Detail C

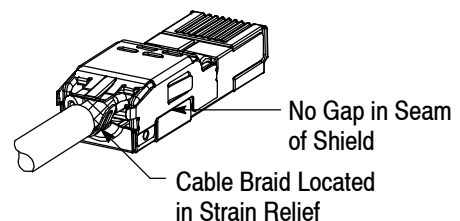
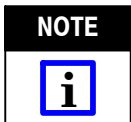

Figure 5



The stated torque must be met in order for the strain relief to seal the plug assembly at the cable end.

3.2. Receptacle Kit

1. Cut the panel using the dimensions provided in Figure 7.

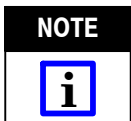

Make sure that the flat edge is located in the desired rotational orientation.

Assembling Plug Kit

Detail A

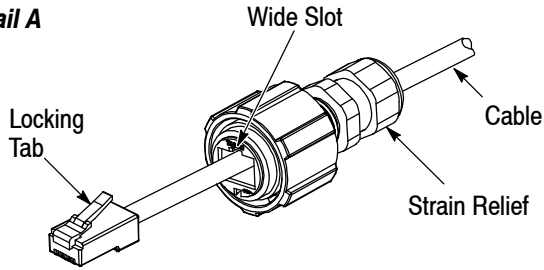

Detail B

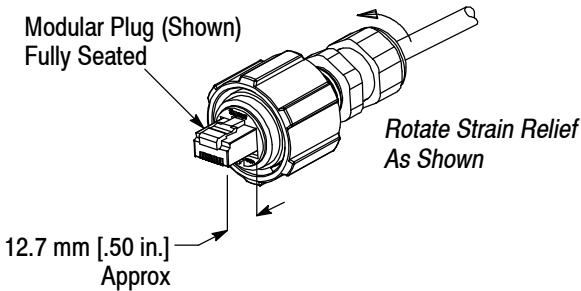

STRAIN RELIEF TORQUE RANGE

PLASTIC SHELL	METAL SHELL
1.7-2.8 N-m [15-25 lbf-in.]	0.9-1.4 N-m [8-12 lbf-in.]

Figure 6

2. Slide the panel gasket over the front (end with bayonet lock) of the receptacle assembly for rear panel mount or over the back of the receptacle assembly for front panel mount until it is flat against the flange. See Figure 8.

3. Align the flat of the receptacle assembly with the flat edge of the panel cutout, and insert the receptacle assembly into the panel until the *panel gasket* is flat against the panel.

4. Thread the panel nut onto the front of the receptacle assembly (for rear panel mount) or onto the back (for front panel mount) and using a torque tool, tighten to a torque of 2.26 N-m [20 lbf-in.]. Make sure that the panel nut is flat against the panel.

NOTE



The given torque must be met in order for the panel gasket to seal the receptacle at the panel.

3.3. Protective Cover Assembly (Refer to Figure 9)

If using the protective cover, proceed as follows:

1. For the plug assembly, slide the loop of the tether over the back (end with the cable fitting) of

Recommended Panel Cutout

Maximum Panel Thickness: 3.18 mm [.125 in.]

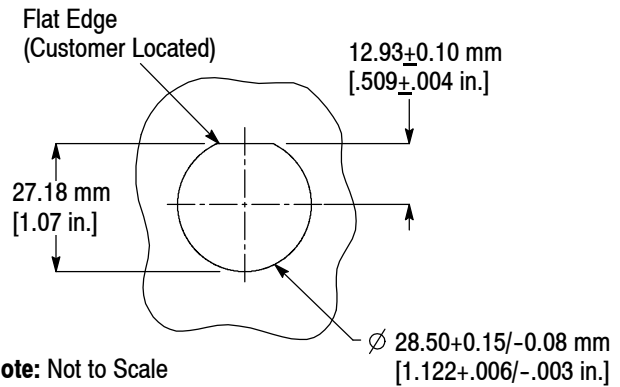

Note: Not to Scale

Figure 7

Assembling Receptacle Kit

Note: Rear Panel Mount Shown

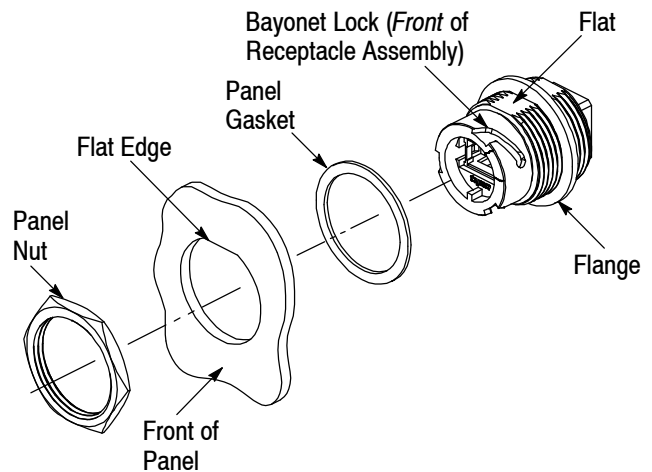

Figure 8

the plug assembly until it is in the groove at the back of the plug assembly. For the receptacle assembly, slide the loop of the tether over the front (end with bayonet lock) of receptacle assembly until it is in the groove at the front of the receptacle assembly.

2. If not engaging connectors immediately, install the protective cover. For the plug assembly, align the slots of the bayonet lock with the protrusions (located inside) of the plug assembly; for the receptacle assembly, align the protrusions (located inside) of the cover with the slots of the bayonet lock of the receptacle assembly. Then rotate the cover until the protrusions “click” onto the bayonet lock.

Installing Protective Cover Assembly

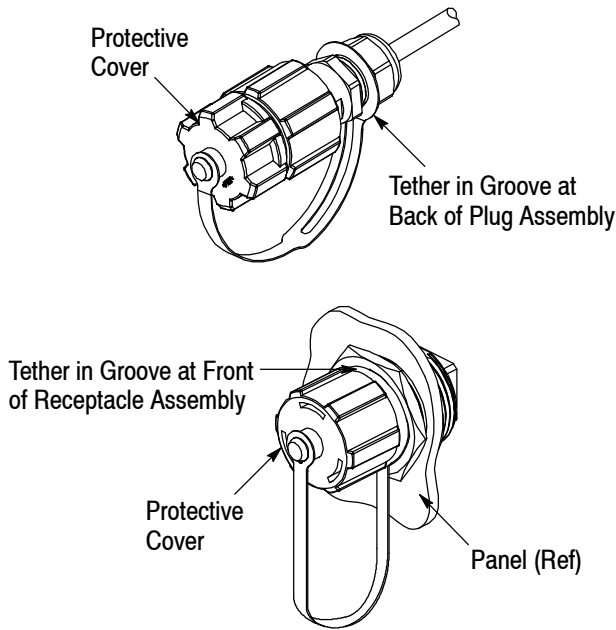
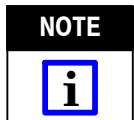

Figure 9

4. ENGAGEMENT (Refer to Figure 10)

1. Align the locking tab (modular plug) or the latch (common core assembly, located at the end of the bottom shield) with the small slot of the modular jack.
2. Rotate the coupling ring of the plug assembly until the protrusions (located inside the coupling ring) align with the slots of the bayonet lock of the receptacle assembly.
3. Engage the plug assembly to the receptacle assembly, then rotate the coupling ring until the protrusions “click” onto the bayonet lock.



NOTE For detailed assembly and inspection requirements, refer to Application Specification 114-13136.

Connector Engagement

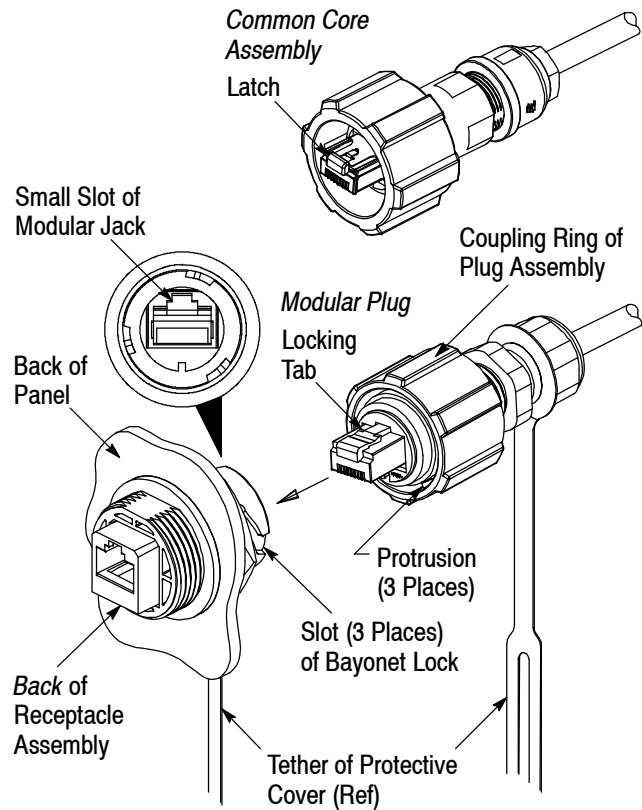

Figure 10

5. REPLACEMENT AND REPAIR

Components of the kits and protective cover assembly are not repairable. DO NOT use defective or damaged components. DO NOT re-use plug assemblies by removing the cable.

6. REVISION SUMMARY

Revisions to this instruction sheet include:

- Updated document to corporate requirements.