

Figure 1

## 1. INTRODUCTION

This instruction sheet provides contact and connector assembly and disassembly procedures, and connector-to-interface mating and unmating procedures for the 0.64 mm Lever Assist Connectors (0.64 mm LAC). The 26-position connector will be used to represent all 0.64 mm LAC products.

### NOTE



All numerical values are in metric units [with U.S. customary units in brackets]. Figures and illustrations are for reference only and are not drawn to scale.

## 2. DESCRIPTION

The 0.64 mm LAC plug assembly consists of a shield assembly and one or more receptacle carriers (Figure 1). The receptacle carrier and shield assembly are packaged and sold separately. Only TE Connectivity (TE) 0.64 mm receptacle contacts (in accordance with the customer drawing and Application Specification 114-13006) can be used with this connector system. The connector is designed to mate with Micro Quad-Lock System (MQS) headers or engineer recommended interfaces.

The receptacle carrier is a component that is installed into the shield assembly after it is loaded with receptacles. This component has plastic latches that temporarily retain the receptacles in position prior to being installed into the shield assembly. In the event that a receptacle is not fully seated or is mis-oriented in the contact cavity, the receptacle carrier is prevented from being installed into the shield assembly.

The shield assembly is made up of a shield housing and lever. The lever is latched in the ready-to-mate (**open**) position when shipped. The lever is released when the plug assembly is mated to an interface. The shield assembly also has a wire exit guide to direct the exiting wires and provide an area for a wire strain relief.

## 3. ASSEMBLY PROCEDURES

### 3.1. Inserting Contacts into Receptacle Carrier

The terminated receptacle contacts must be properly oriented before insertion into the contact cavities of the receptacle carrier (Figure 2). The trapezoidal contact shape and internal housing cavity geometry assist in the correct orientation. Proceed as follows:

1. Insert a terminated contact by grasping the wire approximately 15 mm [6 in.] behind the insulation crimp. Orientate the contact so that the seam of the wire and insulation barrels face the exterior of the receptacle carrier.

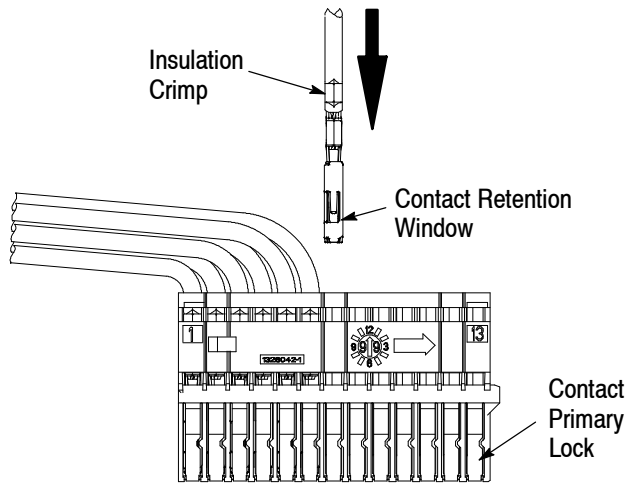

Figure 2

2. Push the contact straight into the appropriate circuit cavity until the contact primary lock on the receptacle carrier snaps securely into the retention window on the contact. The contact primary lock should return to its original un-deflected position.

3. Check for proper contact locking by pulling back lightly on the wire. The contacts should have sufficient clearance when installed so that they are free to drop to the cavity bottom when the receptacle carrier is held in the upright position. Refer to Paragraph 4.3. for contact removal.

**NOTE** *Probe pins are recommended to verify continuity. Refer to the customer drawing for the recommended probe pin layout.*

### 3.2. Installing Receptacle Carrier into Shield Assembly

All contacts must be properly seated before the receptacle carrier can be installed (refer to Paragraph 3.1.). If a contact is not properly seated, interference with a secondary locking rib will occur and prevent the receptacle carrier from being installed. When the receptacle carrier is properly installed, the secondary locking ribs will engage between the receptacle box and the wire crimp area to provide positive contact retention. See Figure 3.

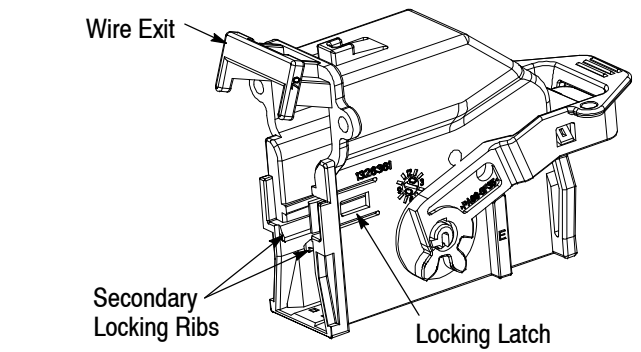

Figure 3

1. For connectors with multiple receptacle carriers, slide the receptacle carriers together. Refer to Figure 1.

**NOTE** *The receptacle carriers must be assembled BEFORE installing them (as a unit) into the shield assembly.*

2. Form all wires in the opposite direction the receptacle carrier will be inserted. There are arrows on both sides of the receptacle carrier that indicate the insertion direction, see Figure 4.
3. Position the receptacle carrier so that the arrows are pointing inside the shield assembly. Align the side channels on the receptacle carrier with the secondary locking ribs on the shield assembly.
4. Slide the receptacle carrier into the shield assembly (the secondary locking ribs will act as a guide rail during installation). The wires must not be constrained or placed in tension prior to loading the receptacle carrier into the shield assembly.

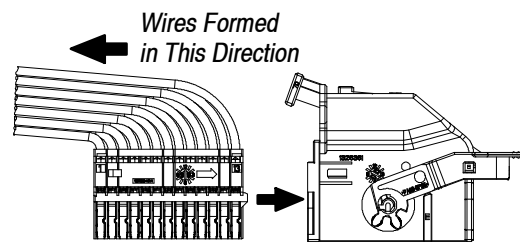

Figure 4

5. Continue pushing the receptacle carrier until the side locking latch (on the shield assembly) drops over the receptacle carriers locking ramp. The latch should return to its un-deflected position and the ramp will be visible in the latch window as shown in Figure 5.

6. Check for proper locking by pulling back lightly on the wire bundle. The receptacle carrier should remain in the locked position.

**NOTE**



A fixture to verify that the receptacle carrier is in the locked position is recommended. Refer to the customer drawing for recommended fixture geometry.

7. If excessive force is encountered before the receptacle carrier is fully installed, remove the receptacle carrier and re-inspect the contacts to make sure they are properly positioned. When using large wire bundles, it may be necessary to adjust the wire arrangement during insertion. Refer to Paragraph 4.2. for receptacle carrier removal.

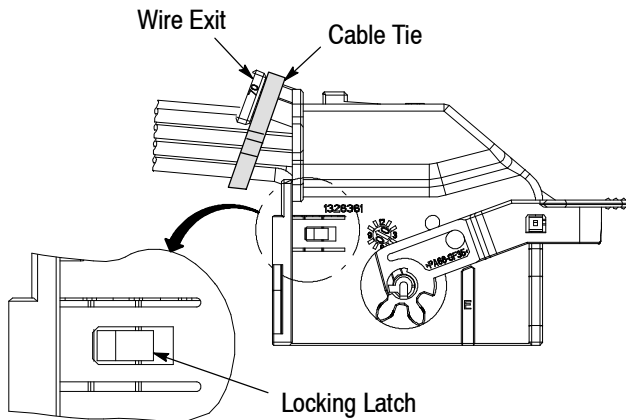

Figure 5

**3.3. Securing Wires to the Shield Assembly**

After the receptacle carrier is installed into the shield assembly, the wire bundle can be secured. The shield assembly contains a wire exit feature to direct the wires and to apply a wire strain relief. Unrestrained wires should be secured to the shield housing before applying insulating tape, cable coverings, securing tape, etc.

1. Secure wire bundle to the wire exit on the shield using a 3 mm [.12 in.] width (or less) cable tie.

2. The cable tie should be positioned so that the locking tab is located below or to the side of the wire exit. This will prevent the cable tie from interfering with the lever in the mated position. See Figure 5.

**3.4. Mating the Plug Assembly (Figure 6)**

The 0.64 mm LAC plug assembly is designed to mate with Micro Quad-Lock System (MQS) headers or TE Engineering recommended interfaces. The plug assembly is keyed with color coding to match the correct interface and insure proper connector orientation.

1. Ensure that the lever is in the “open” ready-to-mate position. The lever should be held in place by either hold-down latches or pre-lock detents. If the lever is not in the “open” position, move it back before inserting the plug assembly into the interface.
2. Orient the plug assembly so that the keying and polarization features are aligned to the interface.
3. Push the plug assembly into the interface until the lever rotates to the pre-lock position and the first audible “click” is heard. The pre-lock detents, located on the side of the shield assembly, should be visible through the lever pre-lock window.
4. From the pre-lock position, grip and rotate the lever until it locks behind the lever lock in the “closed” position. The lever stop and the audible “click” will indicate the lever is locked into position.
5. Once the plug assembly is fully engaged and in the final position, lightly pull back on the lever to ensure that it is properly locked. Refer to Paragraph 4.1. for unmating the plug assembly from the interface.

**Ready-To-Mate Position**

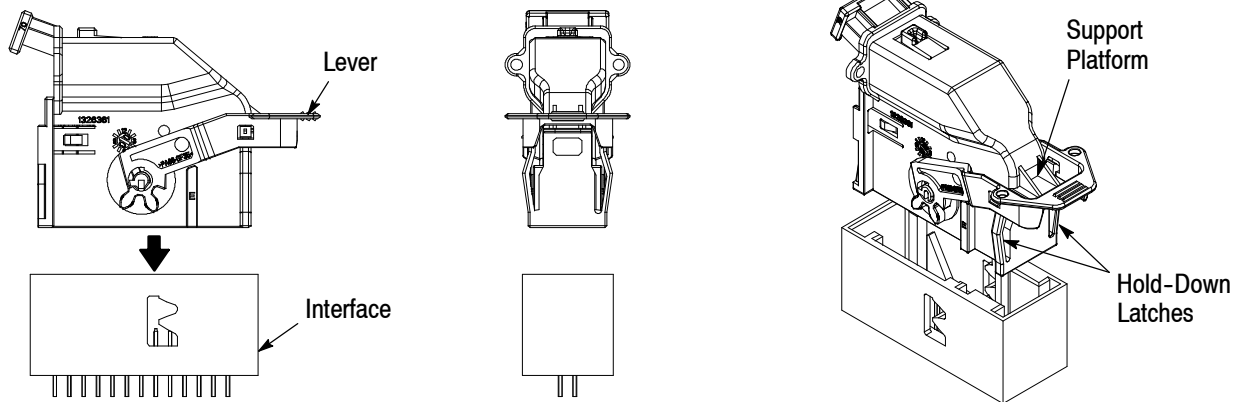
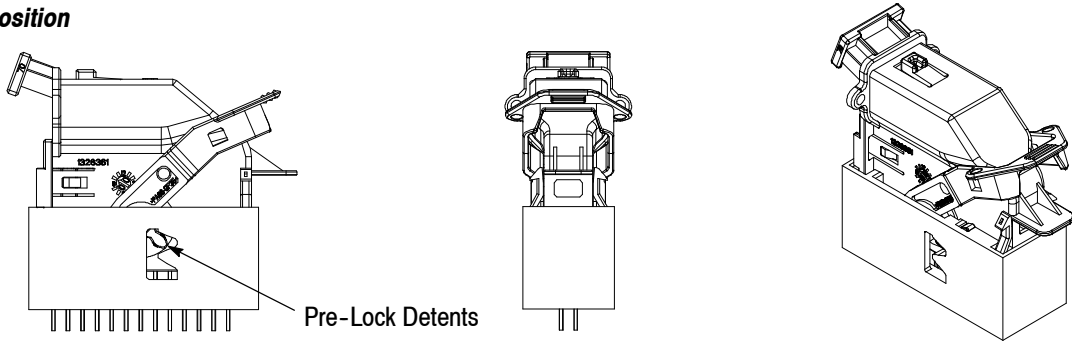

Figure 6 (cont'd)

**Pre-Lock Position**



**Fully Engaged Position**

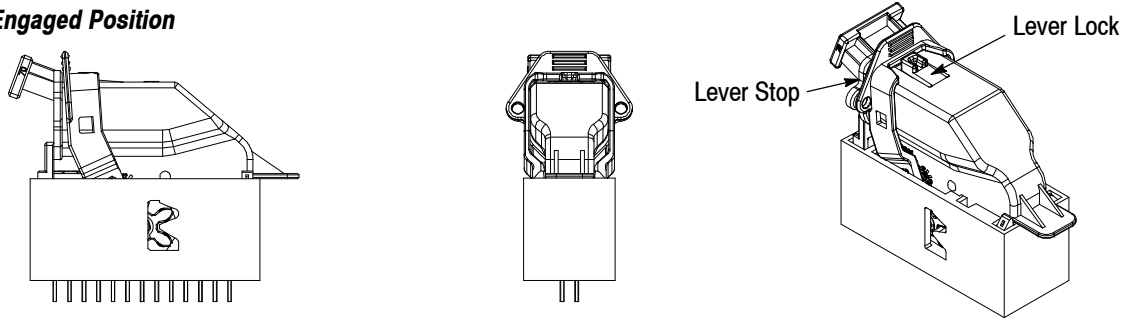

Figure 6 (end)

**4. DISASSEMBLY PROCEDURES**

**4.1. Unmating the Plug Assembly (Figure 7)**

1. To remove the connector from the interface, press down on the lever lock (located on top of the shield housing). A small screwdriver can be used to press the lock down.

2. Once the lever is unlocked, rotate the lever until it rests on the support platform in the “open” position.

3. The plug assembly can then be pulled upwards out of the mating interface. The hold-down latches or pre-lock detents should automatically secure the lever in the “open” position.

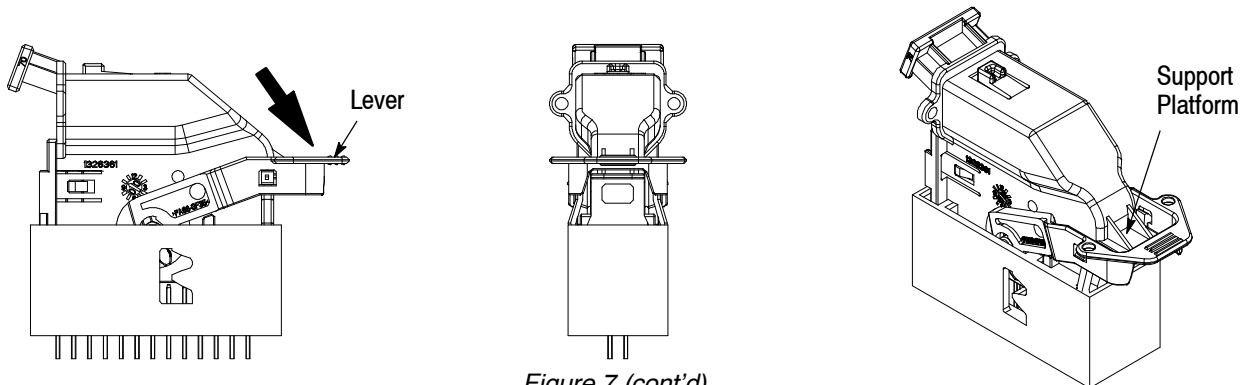
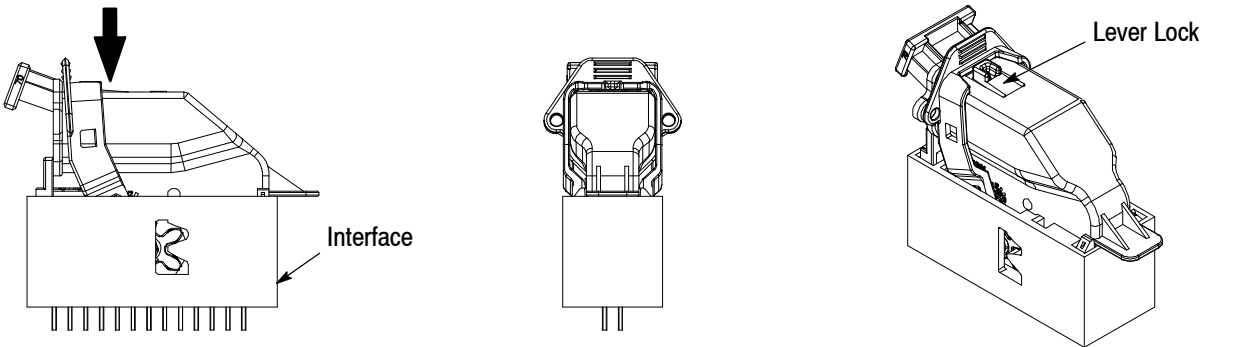

Figure 7 (cont'd)

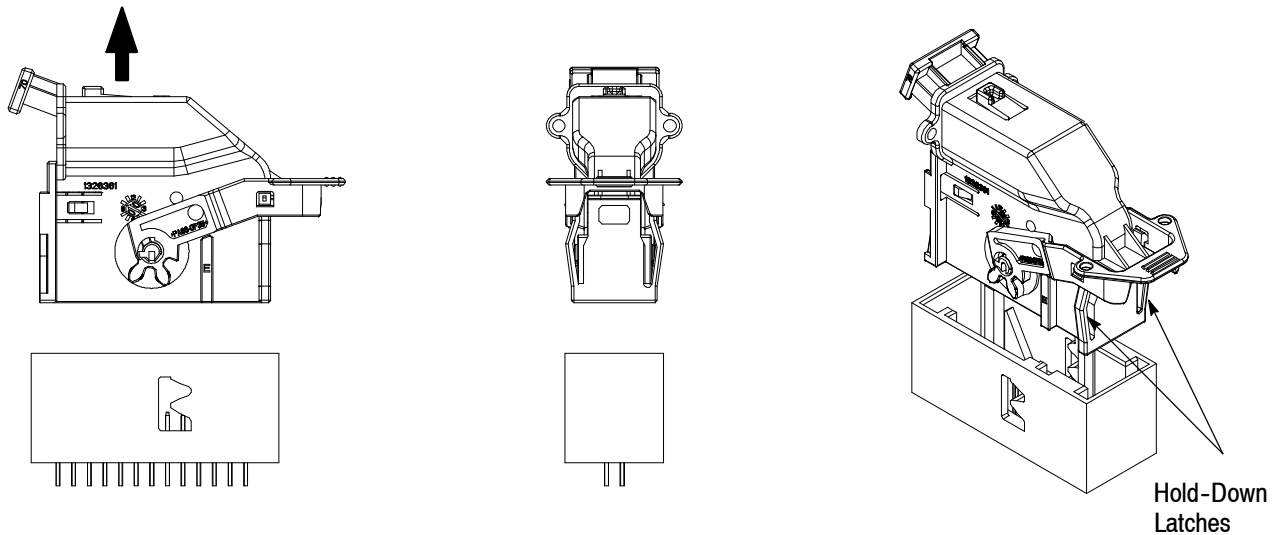

Figure 7 (end)

#### 4.2. Removing Receptacle Carrier from Shield Assembly (Figure 8)

1. Remove the cable tie from the plug assembly. Check to be sure that the individual wires are not damaged.

2. Release the receptacle carrier from the shield assembly by fully deflecting the side locking latch to release the locking ramp from the window, see Figure 5. When the latch is deflected, the receptacle carrier is free to be removed.

3. With the side locking latch held in the deflected position, insert a small screwdriver through the rectangular access window on the opposite end of the shield housing. Push the tool inward and slide the receptacle carrier out of the shield assembly.

#### 4.3. Removing Contacts from Receptacle Carrier (Figure 9)

1. Deflect the contact primary lock so that the tabs on the latch will touch the anti-overstress stops. Do not over-deflect the latch beyond this point.

2. With the contact primary lock deflected, pull on the wire to remove the contact from the receptacle carrier.

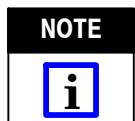

*Damaged components may not be used. If a damaged component is evident, it must be replaced with a new one.*

#### 5. REVISION SUMMARY

- Update document to corporate requirements
- Added new artwork to Figure 1
- Added new NOTEs and text to Paragraph 3.2

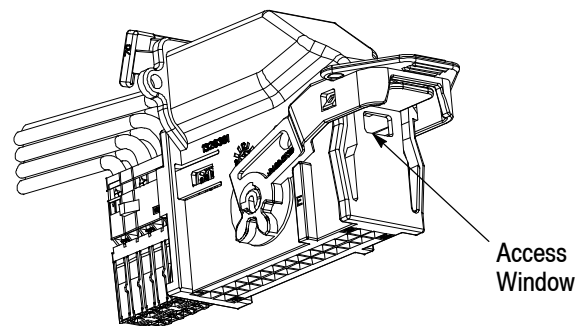
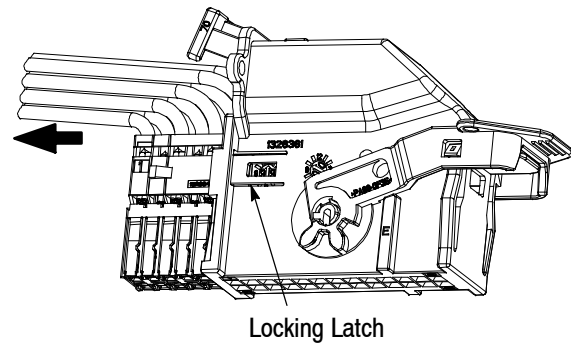

Figure 8

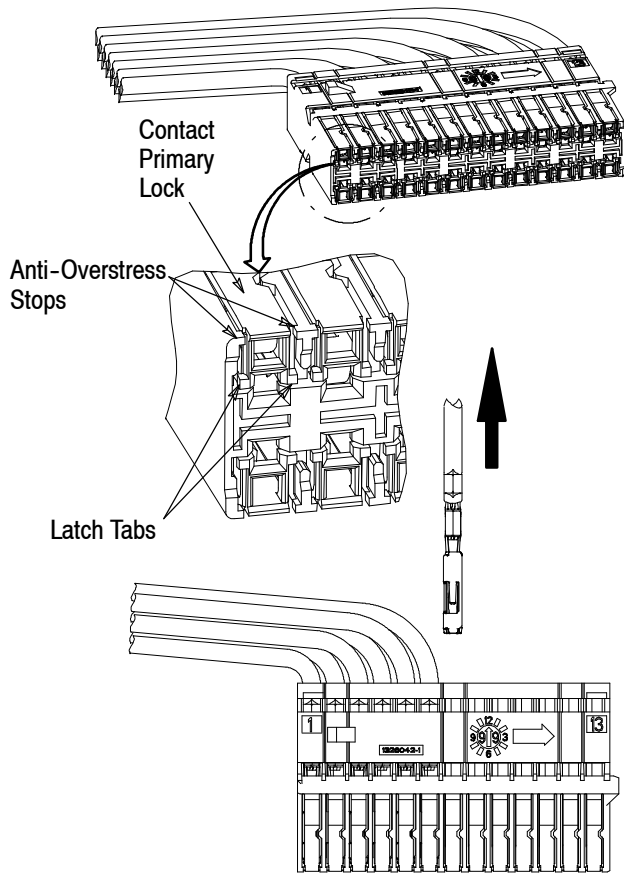

Figure 9