

32-POSITION  
PLUG CONNECTOR  
ASSEMBLY COMPONENTS

Part Number	Description
1326017-[ ]	Header Assembly
1326018-[ ]	Plug Assembly
1326028-[ ]	Female Contact, Au Plated
638553-[ ]	Strain Relief, Right-Out
638557-[ ]	Strain Relief, Tee-Out
638941-[ ]	Strain Relief, Multiple Out

Figure 1

## 1. INTRODUCTION

This instruction sheet provides contact assembly and disassembly procedures for the 0.64 mm Automotive 32-Position Plug Connector Assembly shown in Figure 1. This instruction sheet also provides mating and unmating procedures.

The 32-position plug assembly is designed to operate under Class II temperature and Body and IP vibration profiles. The connector has shunts on the first and fourth rows that short adjacent contacts together when product is not in a mated condition. It is recommended that a strain relief be utilized with this connector. If you have special packaging requirements, please contact your TE Connectivity Representative or the Product Information Center for assistance.

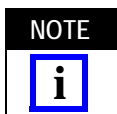

*Dimensions in this instruction sheet are in millimeters. Figures are for reference only and are not drawn to scale.*

Reasons for reissue of this instruction sheet are provided in Section 5, REVISION SUMMARY.

## 2. DESCRIPTION

The plug assembly consists of a housing, a terminal position assurance (TPA) lock, a connector position assurance (CPA) lock, and eight metal shunts. The plug assemblies are shipped as one piece with the TPA and CPA locks in the open (pre-set) position.

The TPA will fully seat when the contact(s) are properly installed. In the event that a contact is not fully seated or is mis-orientated in the contact cavity,

the TPA will not seat or it will be difficult to seat without damaging the TPA. Once the TPA is closed (seated), the plastic terminal latch inside the plug housing cannot be deflected.

The CPA will seat when the plug assembly is fully mated to the header housing. The CPA provides a visual indication that the connector is fully mated. When in the closed (seated) position, the CPA also prevents deflection of the connector latch, thereby preventing accidental unmating.

Strain reliefs and female contacts are sold separately. The contacts are only available in strip form.

## 3. ASSEMBLY PROCEDURES

### 3.1. Contact Insertion

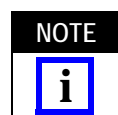

*For information on contact crimping, refer to the instructions packaged with the tooling. For inspection information on crimped contacts, refer to Application Specification 114-13006.*

Check to be sure the TPA lock is in the open (pre-set) position, see Figure 2. If the TPA is closed, refer to Paragraph 4.3, Contact Removal, Steps 1 and 2. Proceed as follows:

1. Insert a terminated contact by grasping the wire approximately 20 mm [.75 inch] behind the insulation crimp and pushing it straight in to the appropriate circuit cavity as far as it will go. Refer to Figure 2.

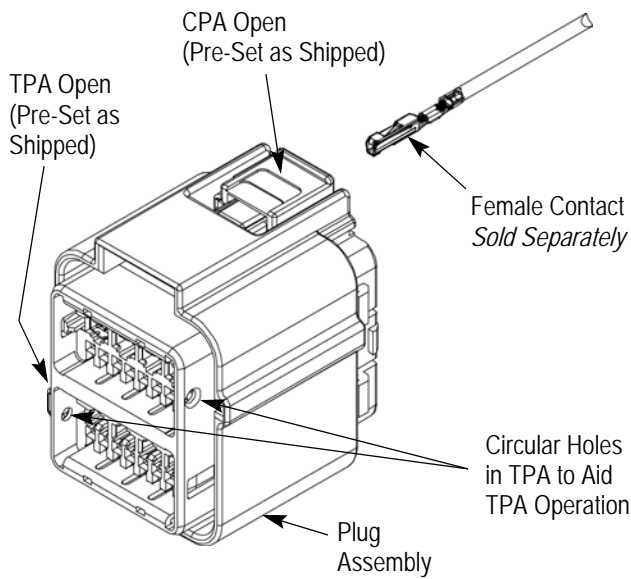
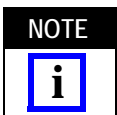

Figure 2



Contact orientation for the first and third row is opposite of contact orientation for the second and fourth rows. See Figure 3.



Contacts for the first and fourth rows must have the shunted plating. Reference Customer Drawing 1326028 (Note 2) to choose correct contact part number. Contacts in rows 2 and 3 should use the non-shunted plating. Reference Customer Drawing 1326028 (Note 1) to choose correct part number.



If the wire should "buckle" prior to full insertion, pull the contact back out of the plug housing. Verify that orientation complies with Figure 3 and reinsert contact.

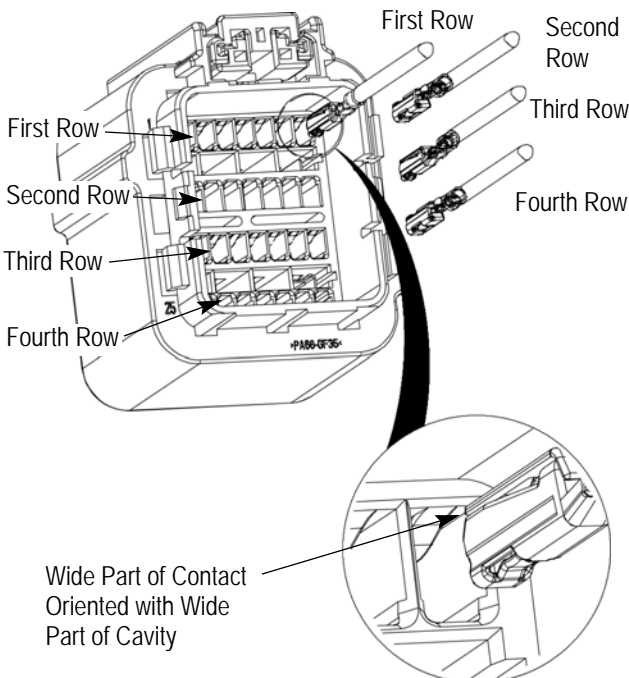

Figure 3

2. Pull back lightly on the wire and contact to ensure the retention finger is holding the contact.

3. After all required contacts have been inserted, the TPA must be closed. To close, push evenly across the TPA lock. The TPA lock should be flush with the plug housing. See Figure 4.

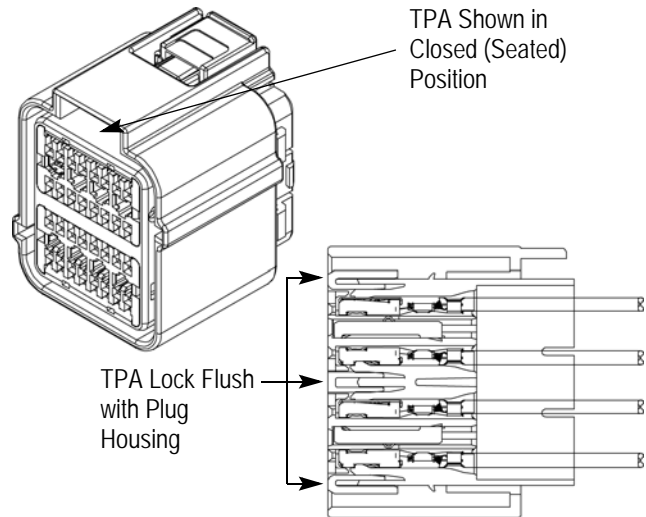

Figure 4

### 3.2. Strain Relief Assembly

Once contacts have been inserted and the TPA has been closed, the strain relief can be installed.

1. If the strain relief has a flap, make sure the flap is in the open position.
2. Assuming the CPA on the plug assembly is up, orient the strain relief so that the opening (or flap) is down.
3. Align the keys on the plug housing with the slots in the strain relief (Figure 5).
4. Using a downward motion, slide the strain relief onto the plug housing.
5. An audible "click" will be heard when the strain relief is fully seated.
6. Route the wire bundle as necessary.
7. Close the strain relief flap (if provided).

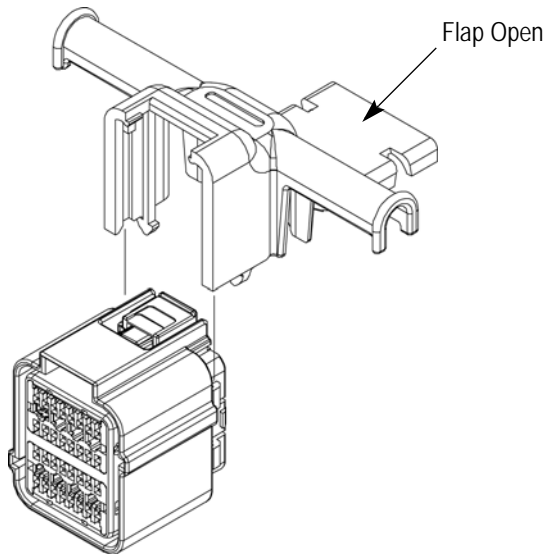

Figure 5

### 3.3. Connector Mating

Orient the plug assembly so the CPA is aligned with the three protrusions on top of the header, and the side keys on the plug housing are aligned with the keys on the header.

1. Push the plug assembly onto the header until an audible “click” is heard.
2. Push the CPA into the closed (seated) position (Figure 6).

**NOTE** *The CPA will not close (seat) unless the connectors are fully mated.*



3. Pull back lightly on the plug assembly to ensure that the connector is properly mated.

CPA in Closed (Seated) Position (Forward)

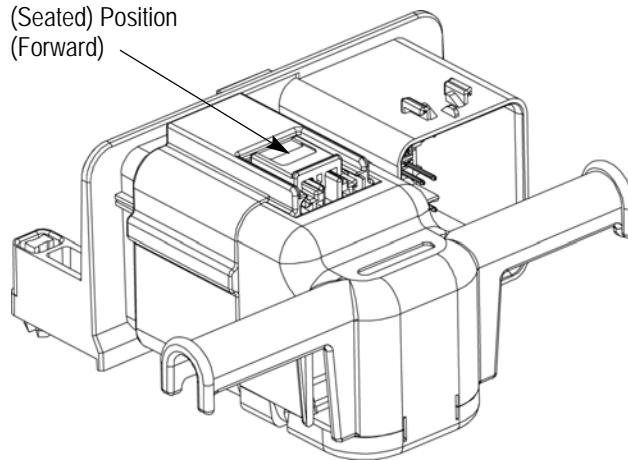

*When CPA is in the closed position, connectors are properly mated and latch cannot be depressed.*

Figure 6

## 4. DISASSEMBLY PROCEDURES

### 4.1. Connector Unmating

1. Move CPA lock back into the open (pre-set) position. See Figure 7.

**NOTE** *It may be necessary to push the plug assembly toward to header to relieve stress on the latch mechanism.*

2. Depress the latch mechanism on the plug housing and pull the plug housing away from the header.

CPA in Open (Pre-Set) Position

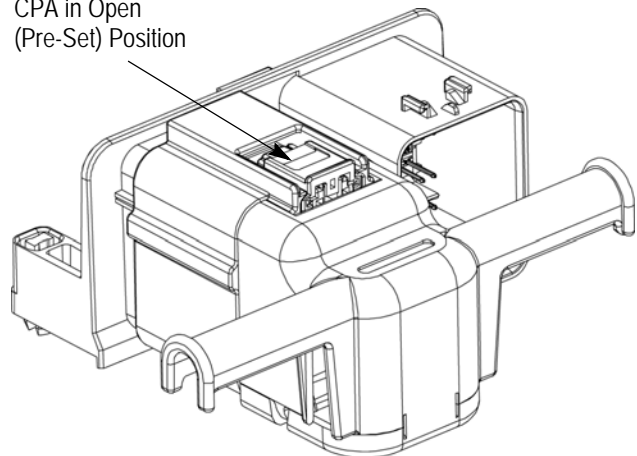

*When CPA is in the open position, connectors can be unmated and latch can be depressed.*

Figure 7

### 4.2. Strain Relief Removal

#### A. Tee-Out Strain Relief 638557-[ ]

1. Unwrap tape from strain relief.
2. Open the flap.
3. Position a jewelers' screwdriver (flat-blade 2.0 or 2.4 mm screwdriver) into the slot in the flap. The tip should be placed between the flap and the latch finger. See Figure 8.
4. Rotate the screwdriver away from the connector. Basically rotate over the latch finger and “pop” the latch.
5. Perform the same technique on the opposite latch.
6. Proceed to Paragraph 4.2.B, Steps 2 through 5.



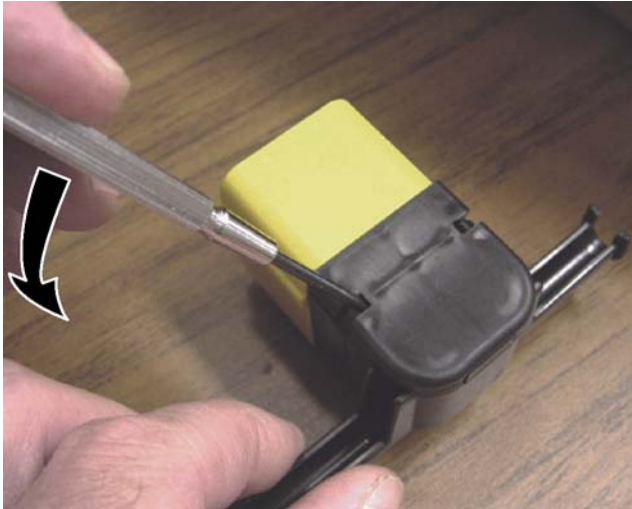

Figure 8

**B. Right-Out Strain Relief 638553-[ ] and Multiple-Out Strain Relief 638941-[ ]**

1. Unwrap tape from strain relief.
2. Looking at the connector latch, place the jewelers' screwdriver (flat-blade 2.0 or 2.4 mm screwdriver) between the vertical connector housing wall and the strain relief.
3. Rotate screwdriver toward the center of the connector while applying slight pressure to the opposite side of the strain relief. This will release the first latch. See Figure 9.
4. Repeat Step 2 with the opposite side.
5. Once the strain relief latches have been released, remove the strain relief by sliding off in a normal direction to the CPA.

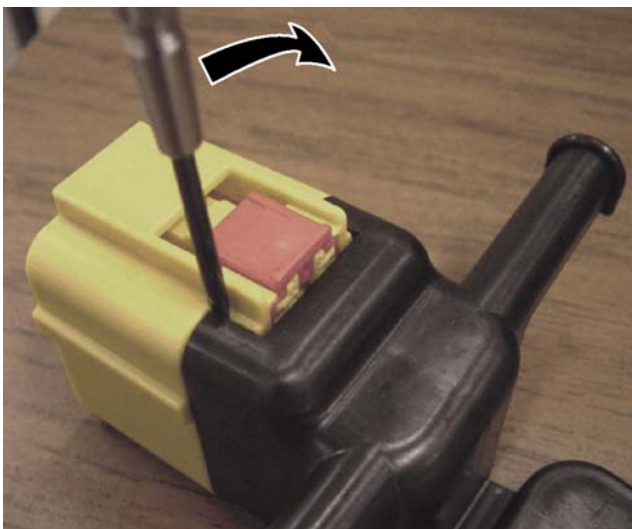

Figure 9

**4.3. Contact Removal**

The connector must be unmated (Paragraph 4.1) and the strain relief, if present, must be removed (Paragraph 4.2). Before removing contacts from the plug housing, the TPA lock must be moved back into the open (pre-set) position. To open the TPA lock and remove the contacts, proceed as follows:

1. Insert a 1.0 - 1.2 mm flat-blade screwdriver into the circular hole in the TPA lock as shown in Figure 10, Detail A.
2. Using the edge of the housing shroud as a fulcrum, rotate the screwdriver toward the wire bundle. Rotate the screwdriver until the retention latch is above the mating face of the plug assembly. See Figure 10, Detail B.

If both latches are not visible, repeat Steps 1 and 2 using the circular hole on the opposite side of the TPA lock. See Figure 10.

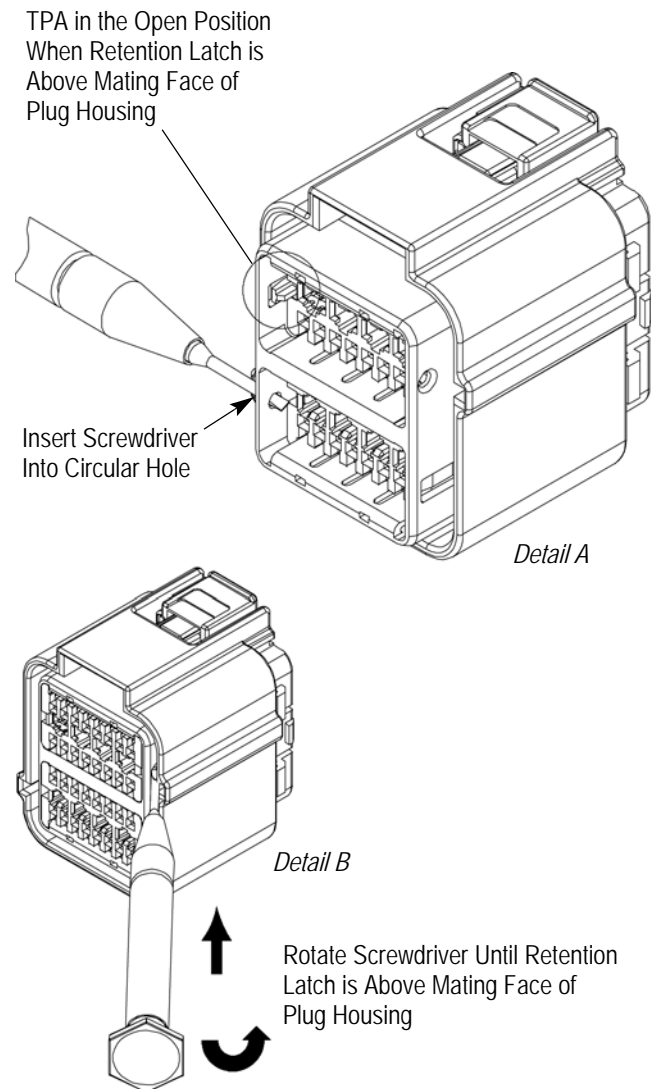

Figure 10

Access Window for Contact Removal  
(36 Windows per Housing)

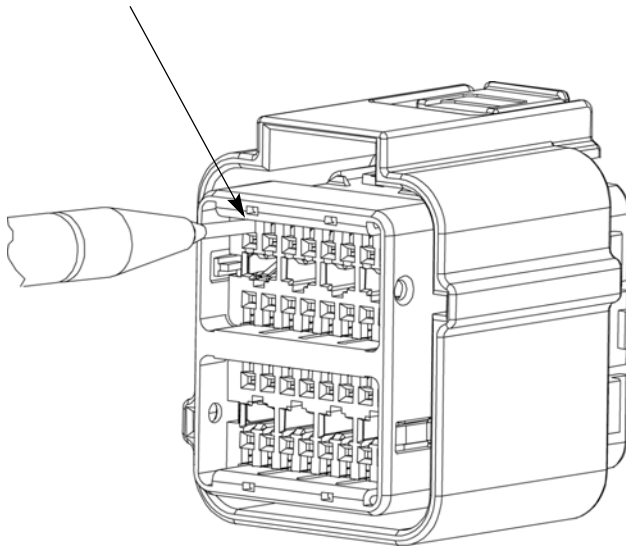
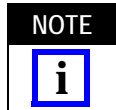

Figure 11

3. Insert a 0.8 - 1.0 mm flat-blade screwdriver into the selected exposed contact cavity, as shown in Figure 11.
4. Grasp the wire of the contact to be removed and push the contact forward until it stops.
5. Using the 0.8 - 1.0 mm flat-blade screwdriver, gently deflect the retention finger. See Figure 12.
6. Simultaneously pull wire and contact from the plug housing.
7. Follow Steps 3 through 6 for remaining contacts.



To reassemble the plug assembly, the TPA lock must be in the open position before insertion of terminated contacts.

### 5. REVISION SUMMARY

Since the previous version of this document, the following change were made:

- Removed logos from graphics.
- Updated document to corporate requirements.

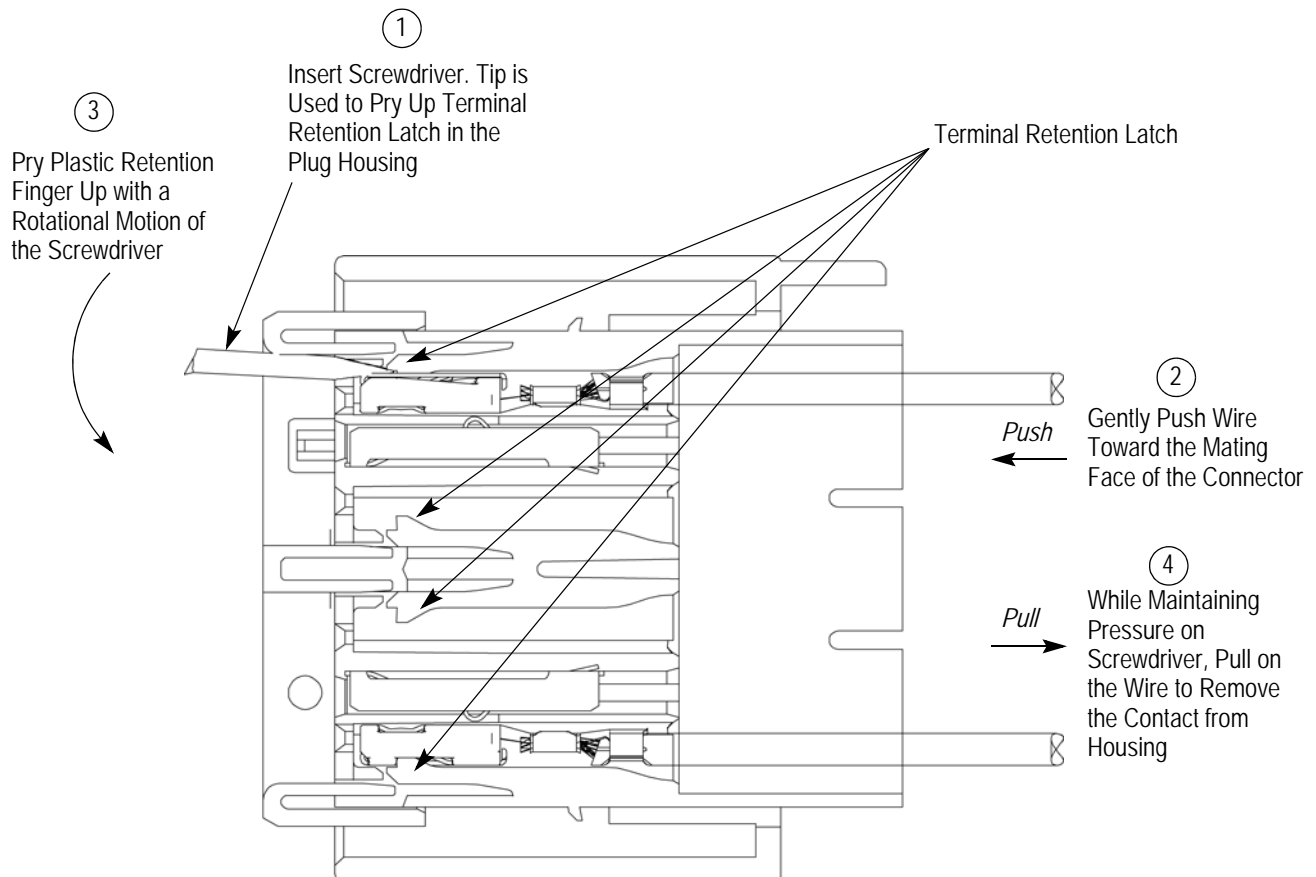

Figure 12