

LIGHTRAY* MPX Cleaning Kit 1457019-2

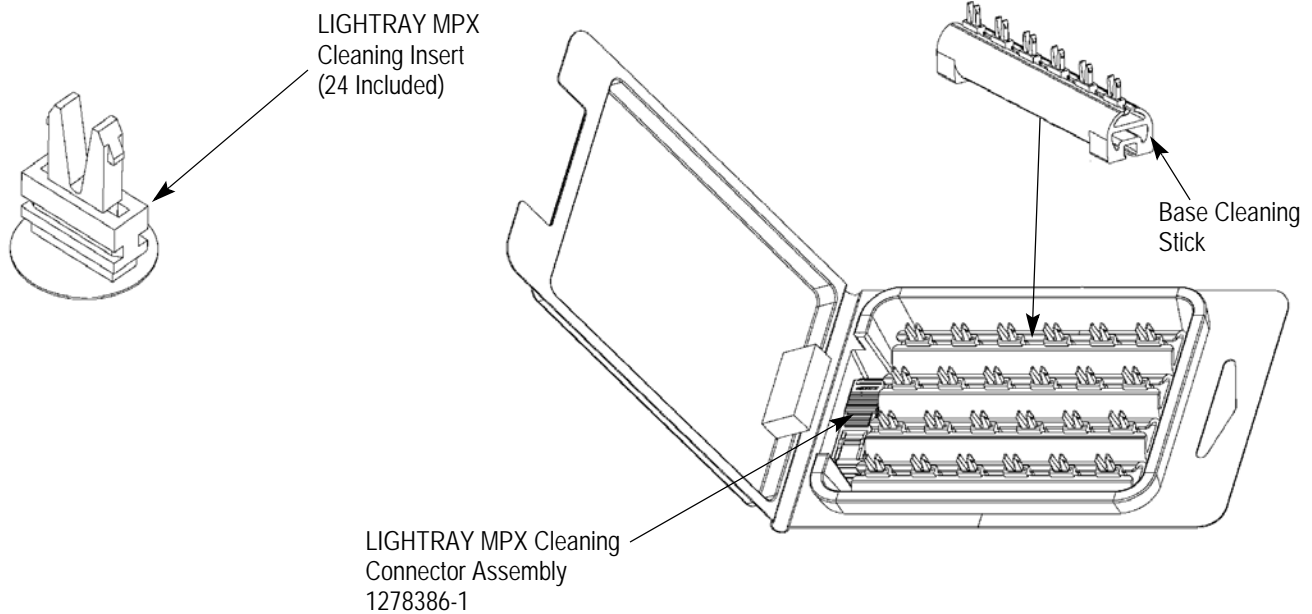
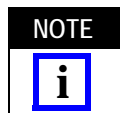

Figure 1

1. INTRODUCTION

This instruction sheet covers the application of LIGHTRAY MPX Cleaning Kit 1457019-2. See Figure 1. The Cleaning Kit will allow the cleaning of backplane mounted LIGHTRAY MPX connectors while still mounted on the backplane.



The cleaning insert is a single cleaning assembly; 1457019-2 is a bulk package of 24 cleaning insert assemblies and a single LIGHTRAY MPX Cleaning Connector Assembly.

Cleaning Connector Assembly 1278386-1 is a single assembly. Part Number 1278386-2 is a bulk package of 25 Cleaning Connector Assemblies.

2. DESCRIPTION (Figure 1)

LIGHTRAY MPX Cleaning Kit 1457019-2 consists of four Base Cleaning Sticks and 24 LIGHTRAY MPX Cleaning Inserts with adhesive material. The kit also contains LIGHTRAY MPX Cleaning Connector Assembly 1278386-1.

These kits are to be used to remove dust that has deposited on the faces of the optical fibers of the LIGHTRAY MPX connector in normal operating conditions. This system is designed specifically to clean hard to reach backplane (BP) mounted LIGHTRAY MPX connectors, but can be used to clean any LIGHTRAY MPX connector.

3. CLEANING PROCEDURE

3.1. Required Tools

The following tools are required to perform the cleaning process on the LIGHTRAY MPX connector:

Tools

- Cleaning Insert
(use one per cleaning and can only be used once)
- LIGHTRAY MPX Cleaning Connector Assembly
(only one is needed and can be reused a maximum of 25 times - after 25 uses, throw the cleaning kit assembly away)

3.2. Cleaning Preparation

A new cleaning insert is required for each LIGHTRAY MPX connector to be cleaned. To install a new cleaning insert in Cleaning Connector Assembly 1278386-1, proceed as follows:

1. Push the cleaning connector assembly down over the insert (located on the base cleaning stick). See Figure 2.
2. Remove the insert (and cleaning connector) by sliding the insert out of the open end of the cleaning stick.
3. Remove the protective paper from adhesive material on the insert.

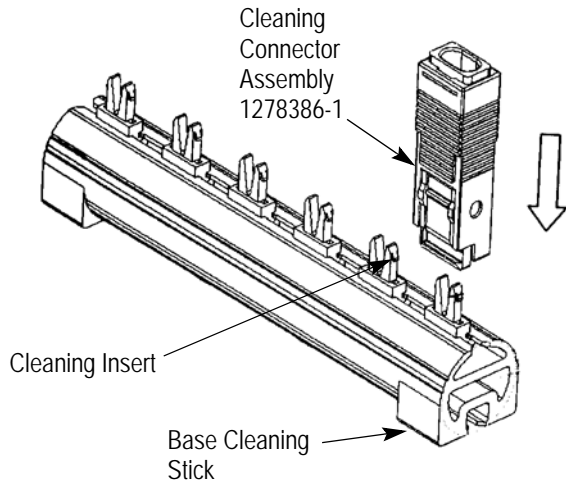

Figure 2

Clean LIGHTRAY MPX connectors as described in Paragraphs 3.3 through 3.6.



To prevent personal injury, always wear eye protection when working with optical fibers. Never look into the end of terminated or unterminated fibers. Laser radiation is invisible but can damage eye tissue. Never eat, drink, or smoke when working with fibers. This could lead to ingestion of glass particles.



Never clean fiber with a dry tissue.



Never use the Cleaning Kit/Insert by itself to clean LIGHTRAY MPX connectors. Always use them as explained in this instruction sheet to prevent damage to the connector.

3.3. Cleaning the Backplane Connector

1. Remove the system card connector being used in application from the system card housing and store the connector, covered, in a safe manner. See Figure 3.

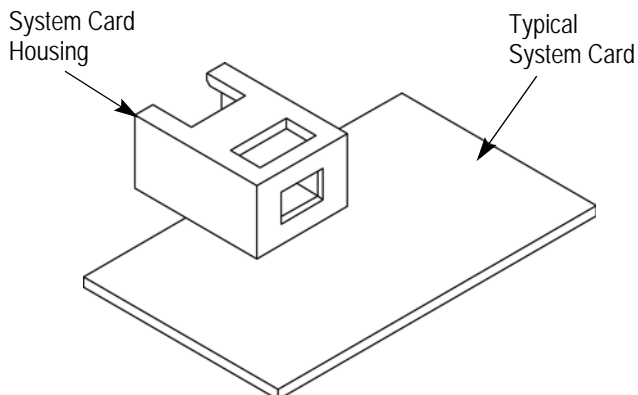

Figure 3

2. Insert Cleaning Connector Assembly 1278386-1 (with cleaning insert installed) into system card housing. See Figure 4,A.
3. Insert system card as would be done during a normal mating of an LIGHTRAY MPX connector in a backplane (BP) application. See Figure 4,B.

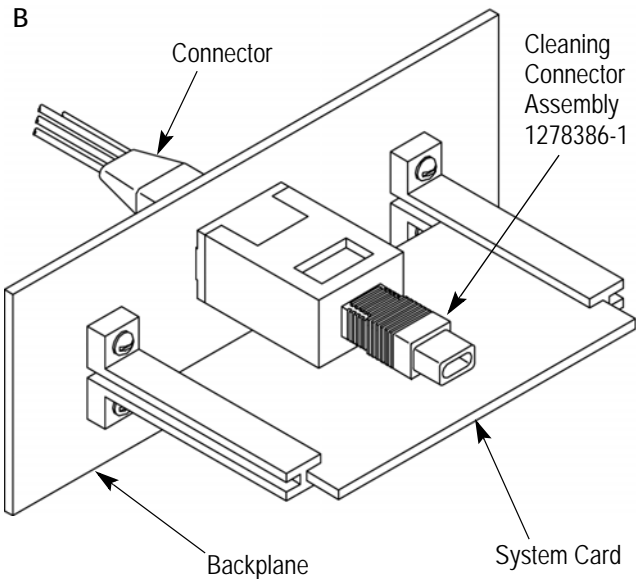
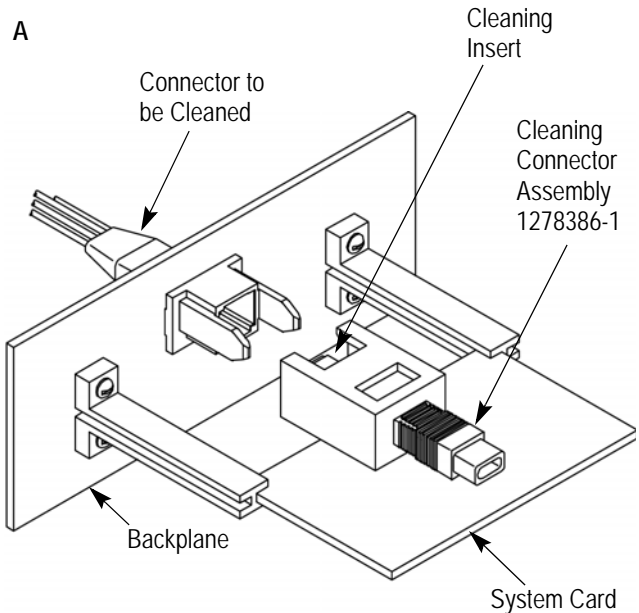

Figure 4

4. Remove system card from the backplane. The backplane LIGHTRAY MPX connector is now clean.

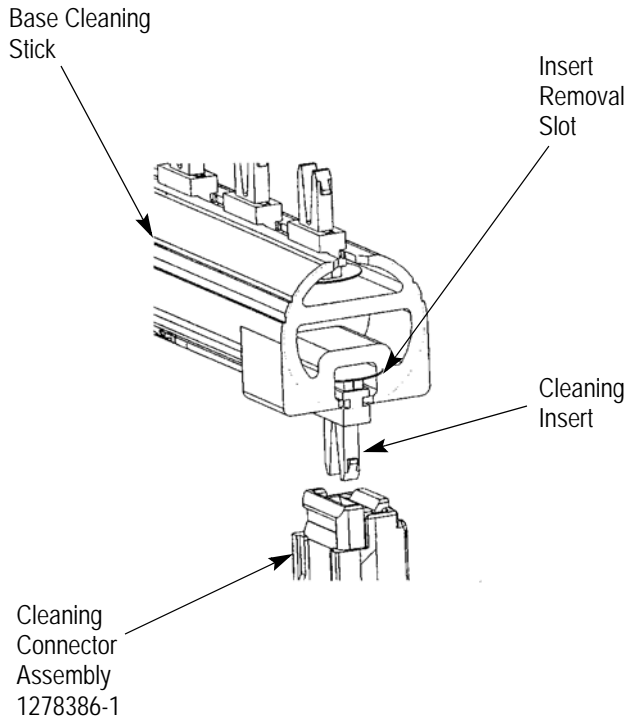
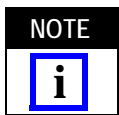

Figure 5

5. Remove the cleaning insert from Cleaning Connector Assembly 1278386-1 by sliding the insert into the removal slot of the base cleaning stick. Pull down on the cleaning connector assembly as shown in Figure 5.

6. Re-install the system card connector into the housing.

7. Clean the system card connector as described in Paragraph 3.4.



The Cleaning Kit can be used with a maximum of 25 Cleaning Inserts before it must be replaced. After 25 uses, throw the Cleaning Kit Assembly away.

3.4. Cleaning the System Card

1. Remove system card from enclosure assembly with system card connector still attached for cleaning purposes. Insert Backplane Housing 492233-1 into system card housing with white ink markings being aligned on the same sides. See Figure 6,A.

2. Insert Cleaning Connector Assembly 1278386-1 (with cleaning insert installed) into the backplane housing. See Figure 6,B.

3. Insert Cleaning Kit as would be done during a normal mating of an LIGHTRAY MPX connector.

4. Remove Cleaning Kit from the motherboard housing. The system card LIGHTRAY MPX connector is now clean.

5. Remove the cleaning insert from Cleaning Connector Assembly 1278386-1 by sliding the insert into the removal slot of the base cleaning stick. Pull down on the cleaning connector assembly as shown in Figure 5.

6. Re-install the system card connector into the enclosure.

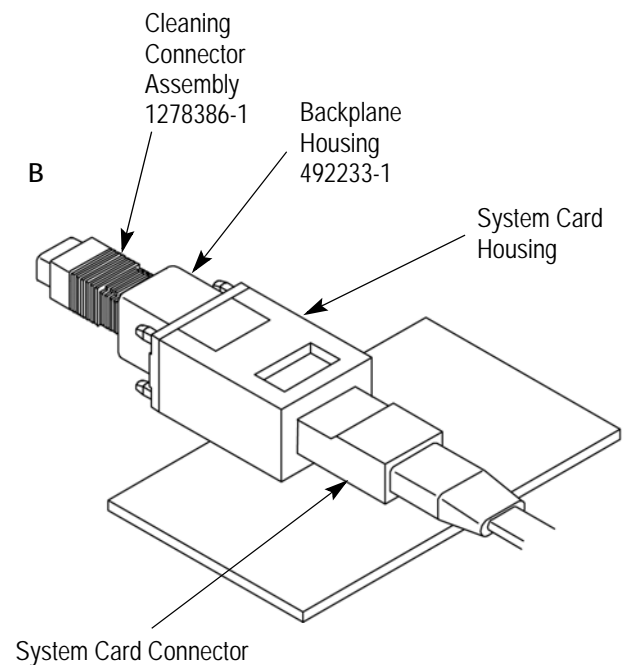
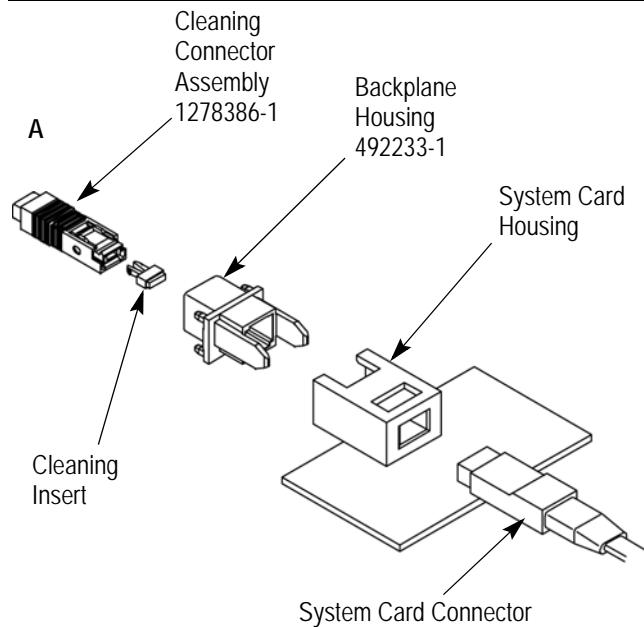

Figure 6

3.5. Cleaning the Bulkhead Mounted Connector

1. While the connector to be cleaned is mounted on Bulkhead 492305-1 (usually in an enclosure), insert Cleaning Connector Assembly 1278386-1 (with cleaning insert installed) into the bulkhead. See Figure 7,A.
2. Insert Cleaning Kit as would be done during a normal mating of an LIGHTRAY MPX connector. See Figure 7,B.

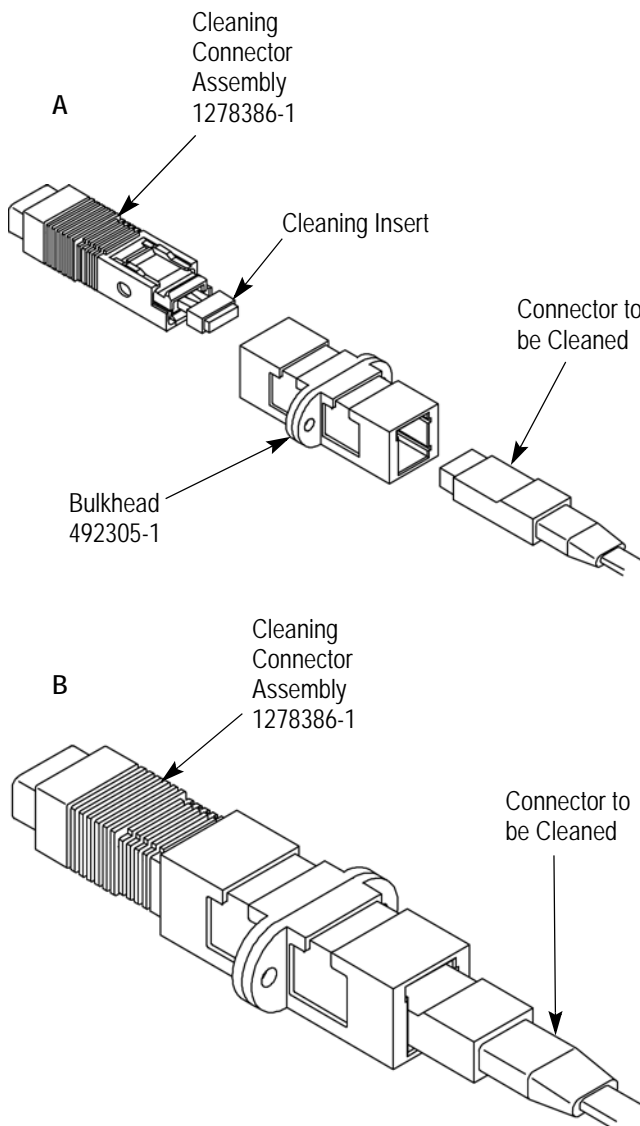
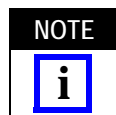

Figure 7

3. Remove Cleaning Connector Assembly 1278386-1 from the bulkhead. The bulkhead LIGHTRAY MPX connector is now clean.
4. Reinstall connectors in proper location.
5. Remove the cleaning insert from Cleaning Connector Assembly 1278386-1 by sliding the insert into the removal slot of the base cleaning stick. Pull down on the cleaning connector assembly as shown in Figure 5.

3.6. Cleaning Multi-Position System Card

1. Remove multi-position system card from enclosure assembly with system card still attached for cleaning purposes.
2. Insert Cleaning Connector Assembly 1278386-1 (with cleaning insert installed) into System Card Cleaning Kit 1374589-[] as shown in Figure 8,A. Multiple Cleaning Connector Assemblies can be placed in the System Card Cleaning Kit to correspond to the number of positions in the mating system card.



Connectors not requiring cleaning can be left in the system card and an empty space can be left in the System Card Cleaning Kit for the corresponding positions. See Figure 8,B.

3. Insert system card as would be done during a normal mating of LIGHTRAY MPX connector in a backplane application.
4. Remove system card from the System Card Cleaning Kit. The system card LIGHTRAY MPX connectors are now clean.
5. Remove the cleaning insert from Cleaning Connector Assembly 1278386-1 by sliding the insert into the removal slot of the base cleaning stick. Pull down on the cleaning connector assembly as shown in Figure 5.
6. Re-install the multi-position system card into the enclosure.

4. REVISION SUMMARY

- Removed old logos from graphics.
- Modified A-B callouts in Figures 4, 6, 7, and 8 for improved clarity.
- Updated document to corporate requirements.

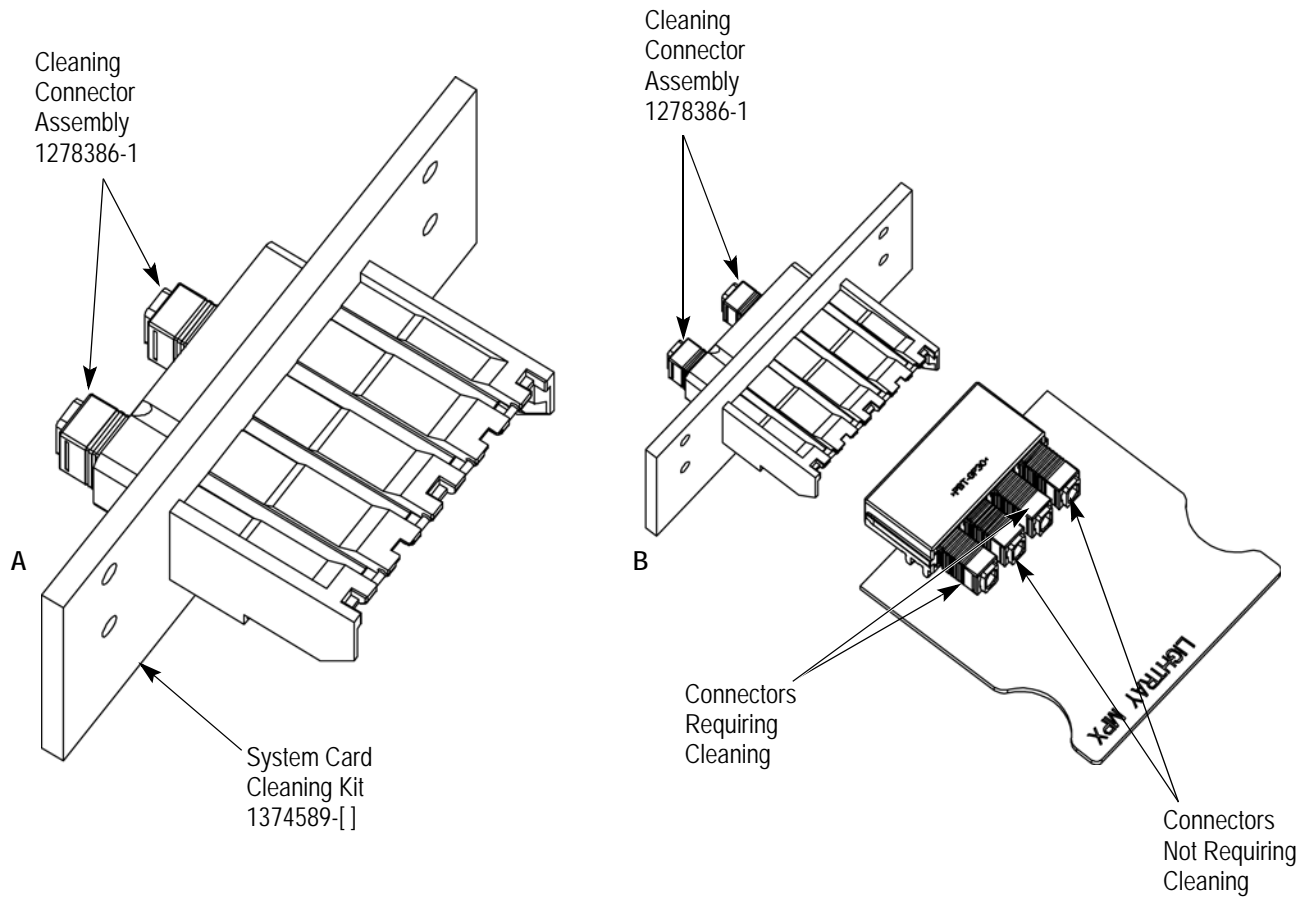

Figure 8