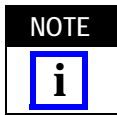

Figure 1

1. INTRODUCTION (Figure 1)

This instruction sheet contains the assembly procedures for 18.0 GHz TNC Straight Cable Plug Direct Solder Attachment 1314249-1 and 1058694-1, which are applied onto .141 semi-rigid coaxial cable or .141 semi-rigid microporous cable.

The table in Figure 2 represents tool numbers applicable to this instruction sheet. The table references the M/A-COM part number to the TE Connectivity part number.



Dimensions on this instruction sheet are in millimeters [with inches in brackets]. Figures are not drawn to scale.

TOOL DESCRIPTION	TE PART NUMBER	M/A-COM PART NUMBER
Fixture Base	1055439-1	2098-5206-54 (T-4567)
Clamp Insert	1055440-1	2098-5207-54 (T-4700-1)
Center Contact Holder	1055474-1	2098-5279-10 (T-4580)
Solder Gage	1055500-1	2098-5516-02 (T-4562-5)
Locator Tool	1055476-1	2098-5282-02 (T-4596)

Figure 2

Reasons for reissue are provided in Section 4, REVISION SUMMARY.

2. DESCRIPTION

The direct solder attachments consist of a housing subassembly and a center contact.

3. ASSEMBLY PROCEDURES

3.1. Preparing Cable (Figure 3)

1. Insert squared cable end into the fixture base, hole pattern No. 2.
2. Place saw in saw slot and cut through outer conductor, and into dielectric while rotating cable.
3. Remove cable from fixture base and finish cutting dielectric with cutting blade.
4. Bare inner conductor by prying the cut outer conductor and dielectric from cable.

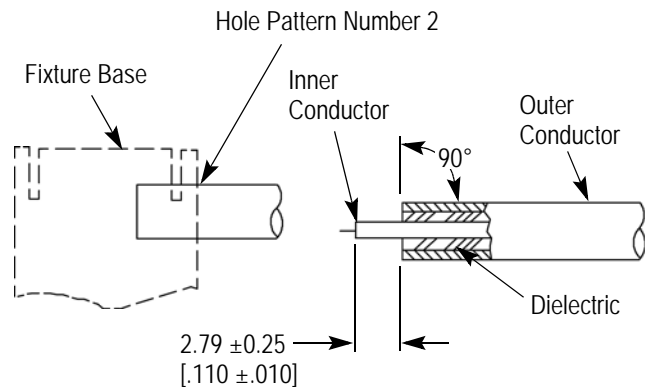

Figure 3

3.2. Soldering of Center Contact to Inner Conductor (Figure 4)

1. Tin inner conductor of cable.
2. Place the solder gage on inner conductor, flush with end of outer conductor.
3. Place center contact in the center contact holder, heat center contact and push it over inner conductor of cable to rest firmly against solder gage.
4. Remove solder gage and excess solder.

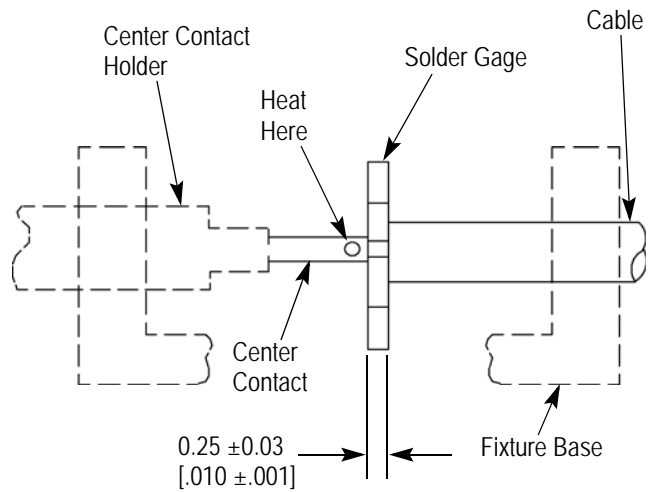

Figure 4

3.3. Soldering of Cable Subassembly to Housing (Figure 5)

1. Place connector housing on end of cable subassembly.
2. Place loose assembly in the fixture base as shown in Figure 5.
 - a. Tighten clamp screw to secure cable.
 - b. Tighten the locator tool to seat cable firmly against housing.
3. Solder cable to housing subassembly as shown in Figure 5.

NOTE *Fixture should be clamped vertically in vise.*

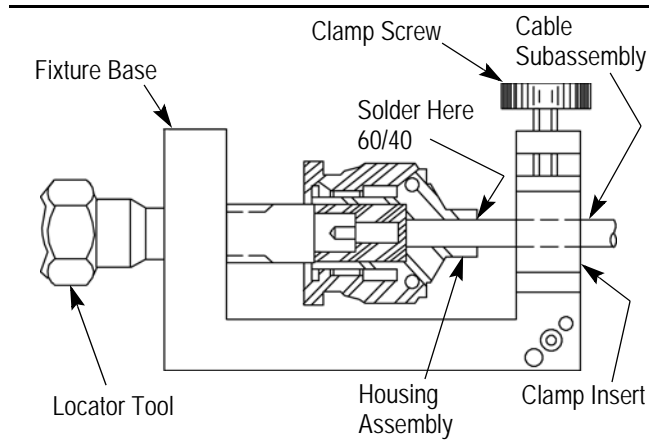

Figure 5

3.4. Inspecting Completed Connector Assembly

Following the assembly procedures in this instruction sheet should yield tolerances shown in Figure 6.

4. REVISION SUMMARY

Since the previous version of this document, the following changes were made:

- Updated document to corporate requirements.

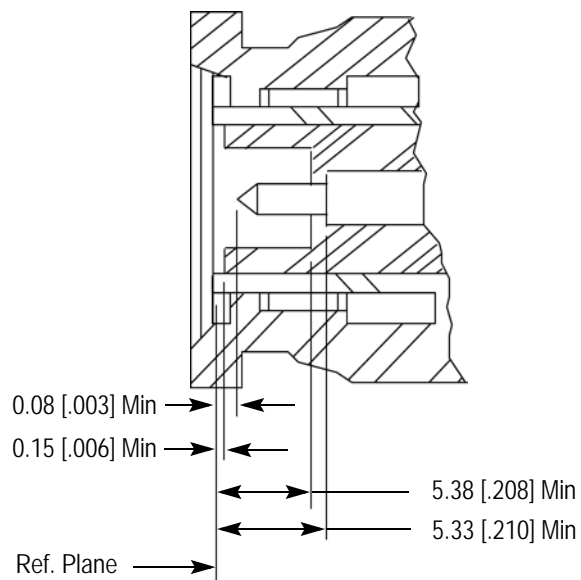

Figure 6