

PROPER USE GUIDELINES

Cumulative Trauma Disorders can result from the prolonged use of manually powered hand tools. Hand tools are intended for occasional use and low volume applications. A wide selection of powered application equipment for extended-use, production operations is available.

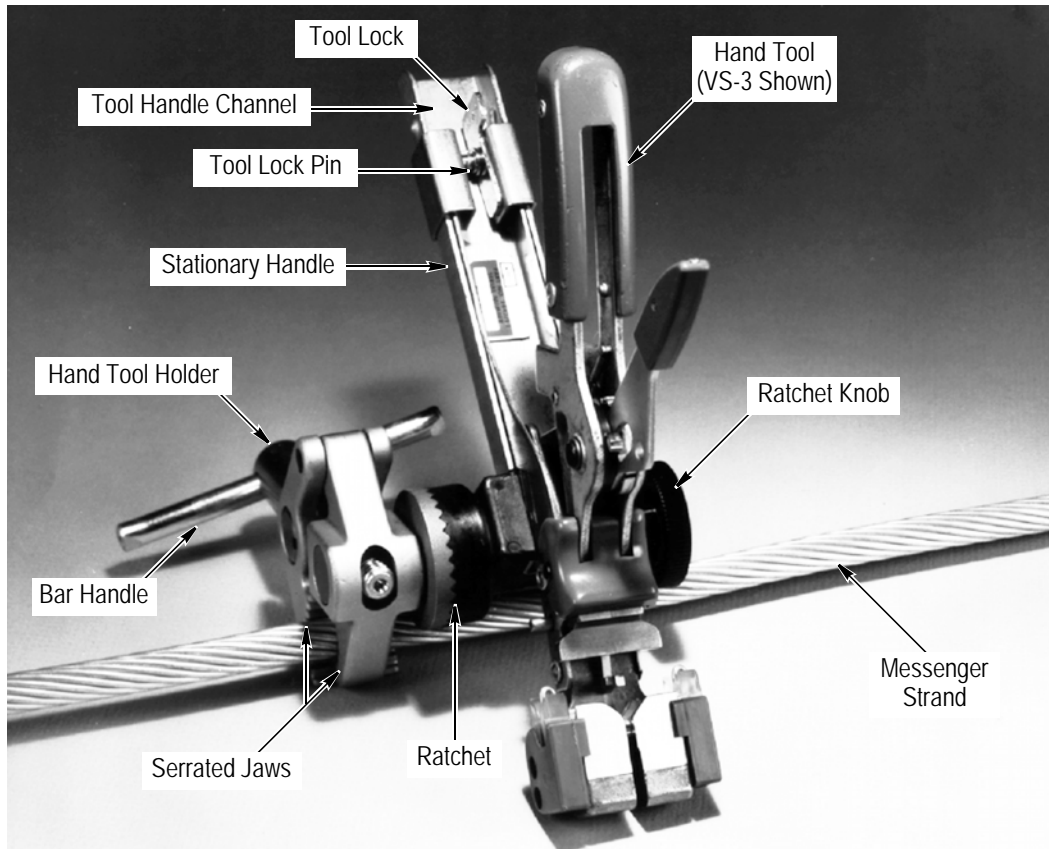
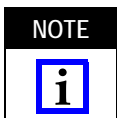

Figure 1

1. INTRODUCTION

Hand Tool Holder 229755-1 shown in Figure 1 is used to support Models VS-3 and MVS-3 hand tools during field assembly. Read these instructions and those packaged with applicable hand tools thoroughly before proceeding.



Dimensions in this instruction sheet are in millimeters [with inches in brackets]. Figures are not drawn to scale.

Reasons for reissue of this instruction sheet are provided in Section 6, REVISION SUMMARY.

2. DESCRIPTION

The hand tool holder features a bar handle, serrated jaws, ratchet, ratchet knob, tool handle channel, and a tool lock. The bar handle is used to open and close the serrated jaws. The ratchet, which permits 360-degree rotation of the hand tool, is opened and closed by

rotation of the ratchet knob. The tool channel accepts the stationary handle of the hand tool, and the tool lock secures the hand tool in the tool holder.

In use, the tool holder is attached to a messenger strand or bracket to support the hand tool. This permits the operator to have both hands free for wire handling purposes.

3. SETUP

3.1. Attaching Tool Holder (See Figure 1)

The tool holder can be attached to a messenger strand or a bracket. When the tool is used with a bracket, the bracket must be attached to the cable ends with hose clamps or other suitable hardware before starting the procedure.

1. Rotate the bar handle until the serrated jaws of the tool holder are opened wide enough to accept the messenger strand (or bracket).

2. Place the serrated jaws of the tool holder around the messenger strand (or bracket), and rotate the bar handle until the serrated jaws are secured to the strand or bracket.
3. Loosed the ratchet knob only enough to release and rotate the tool channel to the desired position. Then re-tighten the ratchet knob.
4. Depress and slide the tool lock toward the ratchet until it bottoms. This step clears the tool channel for the positioning of the hand tool handle.

3.2. Installing Hand Tool (See Figure 1)

1. Start the stationary handle of the hand tool into the tool channel of the tool holder.
2. Slide the tool handle through the tool channel until the tool is at the most desirable position. Check to make sure that one of the holes in the tool channel aligns with the hole in the tool handle.
3. Depress the tool lock and slide it over the tool handle until the tool lock pin aligns with the hole in the tool channel and tool handle. Then release the tool lock.
4. Check to be sure that the tool lock and hand tool are secured.

3.3. Adjustments

A. Extend or Retract Hand Tool in Tool Holder

To extend or retract the hand tool in the tool channel, depress the tool lock and move it and the hand tool to the desired position. Then release the tool lock. Check to be sure all of the components are secured.

B. Rotate Hand Tool 360 Degrees

To rotate the hand tool, loosen the ratchet knob of the tool holder just enough to rotate the hand tool. Rotate the hand tool to the desired position and re-tighten the ratchet knob.

4. HAND TOOL OPERATION (See Figure 2)

Procedures for operating the hand tool with or without the tool holder are basically the same.



During assembly, movement of the crimping head should be avoided to prevent wire pull-out before the connector is crimped.

1. Position the connector and wires in the hand tool according to instructions packaged with the hand tool. For the VS-3 Hand Tool, refer to Instruction Sheet 408-7280, and for the MVS-3 Hand Tool, refer to 408-6539.

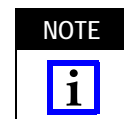

When using the VS-3 hand tool, place the through wires ABOVE the wire support splitter pins. Place all other tap and splice wires BELOW the wire support splitter pins. The MVS-3 hand tool does NOT have wire support splitter pins.

2. Support the stationary handle of the tool with one hand. Then depress the quick take-up lever and squeeze the moving handle with the other hand until the moving handle bottoms. Refer to Figure 2.
3. Release the handles of the hand tool, and remove the crimped connector.

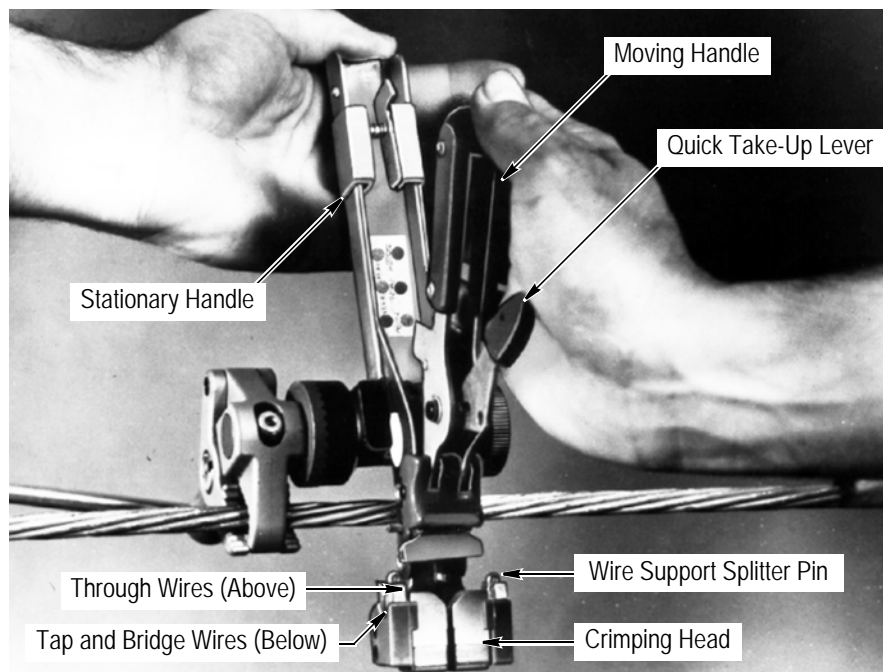

Figure 2

5. REPLACEMENT AND REPAIR

Customer-replaceable parts are listed in Figure 3. A complete inventory should be stocked and controlled to prevent lost time when replacement of parts is necessary. Parts other than those listed should be replaced by TE Connectivity to ensure quality and reliability. Order replacement parts through your Representative, or call 1-800-526-5142, or send a facsimile of your purchase order to 717-986-7605, or write to:

CUSTOMER SERVICE (038-035)
 TYCO ELECTRONICS CORPORATION
 PO BOX 3608
 HARRISBURG PA 17105-3608

For customer repair service, call 1-800-526-5136.

6. REVISION SUMMARY

Revisions to this instruction sheet include:

- Changed company name and logo
- Removed trademark name of applicator

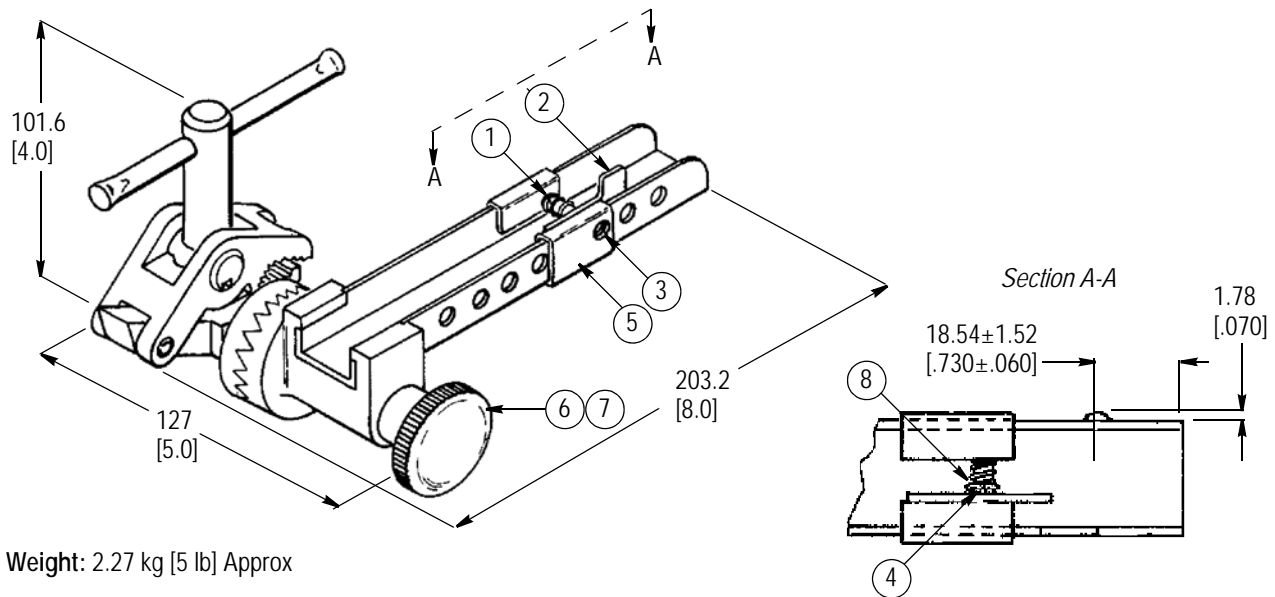

Weight: 2.27 kg [5 lb] Approx

REPLACEMENT PARTS

ITEM	PART NUMBER	DESCRIPTION	QTY PER TOOL HOLDER
1	22280-1	SPRING, Compression, 6.10 Dia x 9.65 L [.240 Dia x .380 L]	1
2	250006-1	TAB, Release	1
3	250005-1	PIN, Locking	1
4	21110-3	RING, Retaining	1
5	250007-1	CLIP, Retaining	1
6	27665-1	KNOB, Knurled	1
7	6-22282-5	SPRING, Compression, 9.14 Dia x 19.05 L [.360 Dia x .750 L]	1
8	230223-1	WASHER	1

Figure 3