

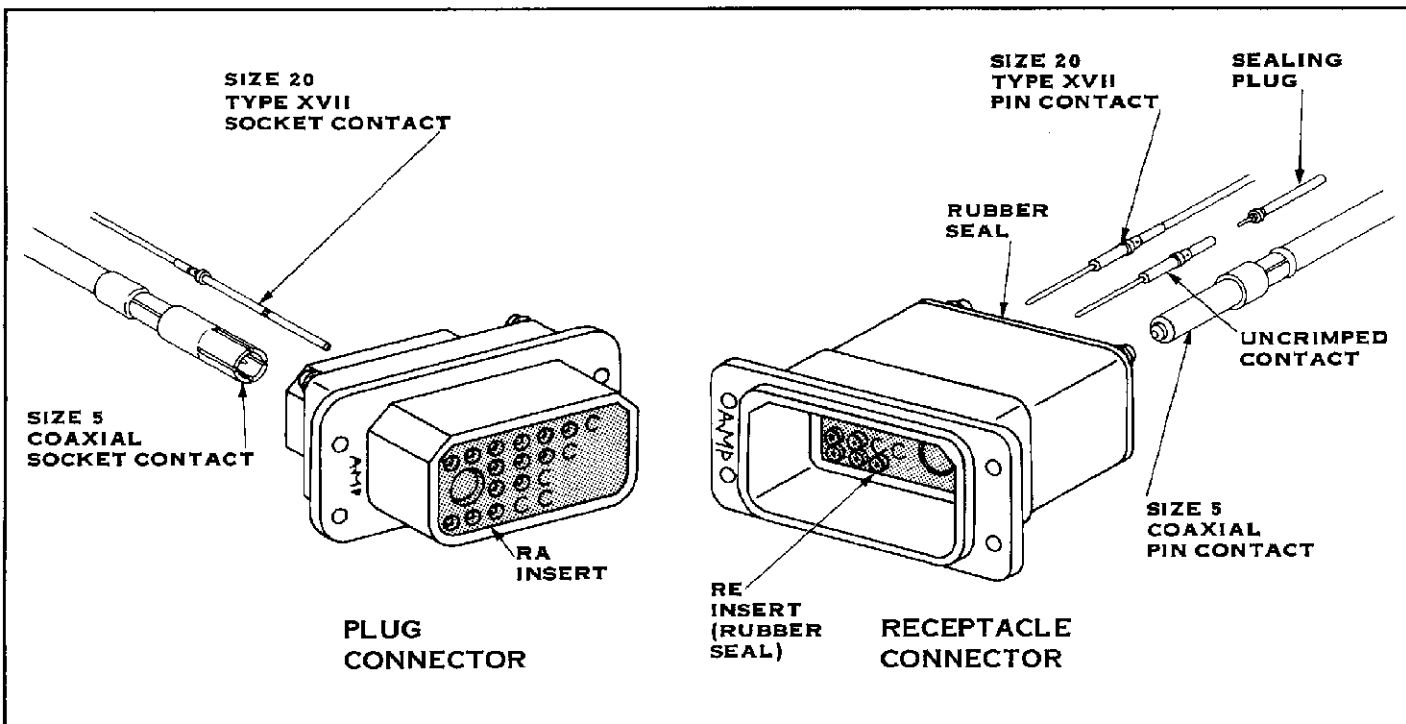

AMP★ RA AND RE CONNECTORS  
FOR  
ARINC APPLICATIONS

REDUCED FOR PACKAGING

<b>IS 7589</b>	
RELEASED	9-18-72
REVISED	



INSERT		CONTACT				WIRE SIZE	HAND CRIMPING TOOL		INSRN/EXT TOOL
TYPE	NO. OF POS.	SIZE	QUANTITY	PIN	SOCKET		TOOL	POSITIONER	
RA and RE	29C1	20	28	204938	205116	24-20	601966-1	601966-5	91066-2
		5	1	225790-1	225791-1	RG 58C,141	601966-1	2-601966-6	91074-1
	24C2	20	22	204938	205116	24-20	601966-1	601966-5	91066-2
		5	2	225790-1	225791-1	RG 58C,141	601966-1	2-601966-6	91074-1
	32	20	32	204938	205116	24-20	601966-1	601966-5	91066-2

FIGURE 1

**1. INTRODUCTION**

These instructions cover the assembly and installation of the AMP RA and RE ARINC Rack and Panel Connectors shown in Figure 1. Read this material thoroughly before starting.

**2. DESCRIPTION**

The difference between the two types of Connectors is that the RE Connectors have a Rubber Seal on both sides of the Insert for environmental sealing and the RA Connectors do NOT. Both types are available with various styles of inserts as shown in the chart in Figure 1. Sealing Plugs are provided with RE Connectors for unused contact cavities.

**3. INSERTING SEALING PLUGS**

Sealing Plugs are designed to seal unused cavities in RE Connectors. To install a Sealing Plug, first insert an uncrimped contact into the applicable cavity. Then insert the Plug (small pointed end first) into the contact cavity until it bottoms. The Sealing Plug should protrude approximately 1/32 inch from the Rubber Seal.

**4. CONTACTS**

**Selection** — Determine the Wire Size specified for the application, then refer to the chart in Figure 1 and select the applicable contact and crimping tool.

**Crimping** — The Instruction Sheets packaged with the crimping tools (IS 2348 for Size 5 contacts and IS 7516 for Size 20 contacts) provides the Wire Strip Length and the contact crimping procedure. Read these instruction carefully before crimping the contacts.

These Connectors are designed for REAR insertion and extraction of the contacts. They accept Type XVII, Size 20 and Size 5 Coaxial Contacts. We recommend that you insert Pin Contacts in the Receptacle Connector and Socket Contacts in the Plug Connector.

Copyright 1972 by AMP Incorporated, Harrisburg, Pa. All International Rights Reserved. AMP Incorporated products covered by U.S. and Foreign patents and/or patents pending.

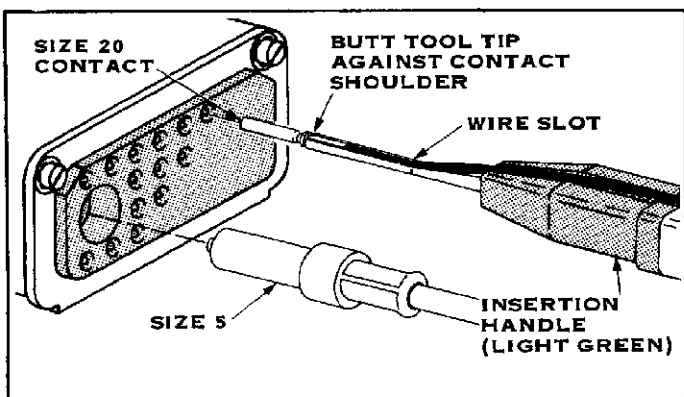

FIGURE 2

**Insertion** — An Insertion Tool is not needed for inserting the Size 5 Coaxial Contacts. Simply align the crimped contact with the BACK of the Contact Cavity and push it straight into the Cavity until it bottoms. Pull back lightly on the wire to be sure the contact is locked in position.

The Light Green Handle of the AMP Insertion/Extraction Tool 91066-2 contains the Insertion Tip for Size 20 Pin and Socket Contacts.

Use this tool as follows: (See Figure 2)

1. Place the wire over the Wire Slot of the Insertion Tip and hold it in this position with your thumb.
2. While applying light pressure on the wire, slide your thumb toward the tip of the tool. The tip will spread; allowing the wire to enter the tip.
3. Position the Tool Tip against the Shoulder of the Contact as shown in Figure 2. (Note that the Beveled Tip is smaller than the outside diameter of the Contact Shoulder. This allows the Locking Lance in the cavity to grip the shoulder of the Contact.)
4. Press the wire against the Tool Handle to hold the contact in position.
5. Align the contact with the cavity and insert the contact straight into the cavity until it bottoms.
6. Remove the tool. Then pull back lightly on the wire to make certain the contact is locked in the cavity.

**Extraction** — The AMP Extraction Tool 91074-1 is designed to remove Size 5 Pin and Socket Contacts from these connectors. Read the Instruction Sheet (IS 7542) packaged with the tool for the proper extraction procedure.

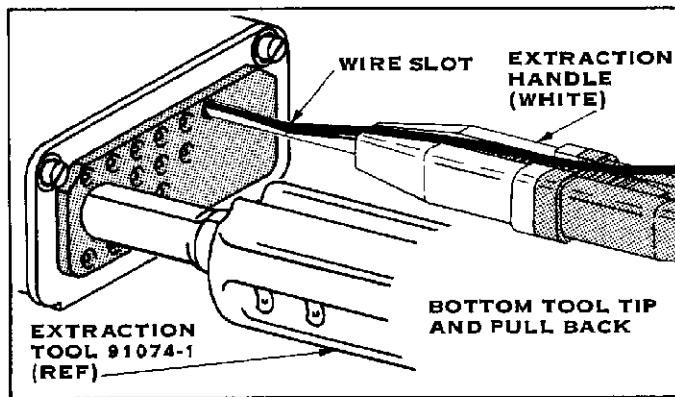

FIGURE 3

The White Handle of the AMP Insertion/Extraction Tool 91066-2 contains the Extraction Tip for Size 20 Pin and Socket Contacts.

Use this tool as follows: (See Figure 3)

1. Place the wire over the Wire Slot of the Extraction Tip and hold it in this position with your thumb.
2. Apply light pressure on the wire and slide your thumb toward the tip of the tool. The Tip will spread; allowing the wire to enter the tip.
3. Insert the Tool Tip straight into the cavity until it bottoms.
4. Hold the Wire against the Tool Handle. Pull the Tool and Contact straight out the back of the cavity. See Figure 3.

## 5. MOUNTING CONNECTORS

These connectors are designed for rack and panel mounting. We recommend that you front-mount the Plug to the rack and back-mount the Receptacle to the panel. The panel thickness should not exceed 1/16 inch to assure proper mating. Refer to Figure 4 for the suggested panel cutout dimensions. These same dimensions can be used to determine the location of the rack.

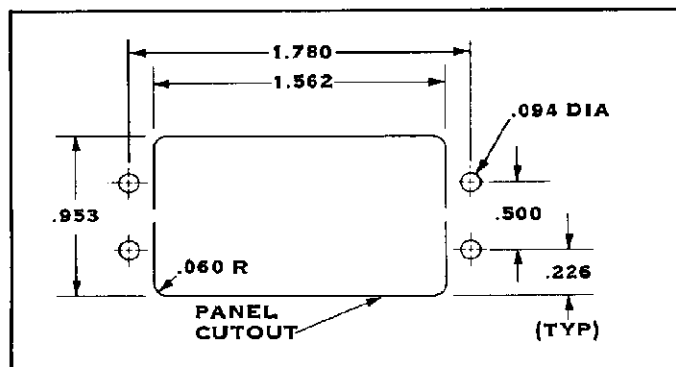

FIGURE 4