

TYCO ELECTRONICS PART NUMBER	DESCRIPTION	CABLE
1060774-1	MCX Straight Cable Jack	.085 S/R
1060774-2	MCX Straight Cable Jack	.047 S/R

Figure 1

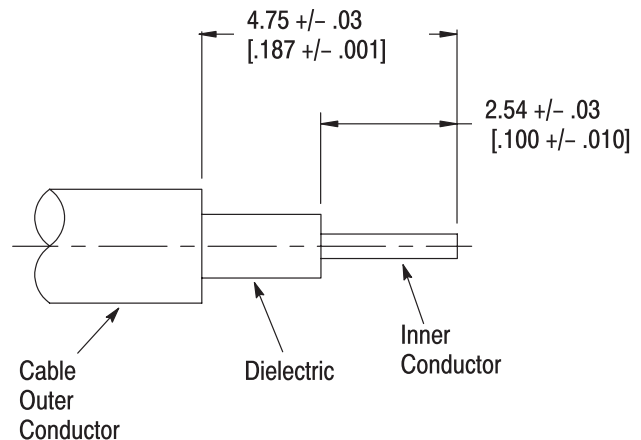

Figure 2

## 1. INTRODUCTION

This instruction sheet contains the assembly procedures for the MCX Straight Cable Jacks shown in Figure 1. These connectors are a solder attachment type connector that attach to .085 S/R cable and .047 S/R cable.

No special tools (other than soldering equipment and cutting equipment) are required.

Revision information can be found in Section 4.



*Dimension on this sheet are in millimeters [with inches in brackets], unless otherwise specified.*

## 2. DESCRIPTION

The MCX Straight Cable Jacks contain a housing assembly and a contact. See Figure 1.

## 3. ASSEMBLY PROCEDURE

### 3.1. Preparing the Coaxial Cable End

1. Remove the end portion of the cable jacket to expose the cable dielectric and cable inner conductor.
2. Trim the dielectric and inner conductor as shown in Figure 2.

### 3.2. Soldering the Center Contact to the Cable Inner Conductor



*To avoid personal injury, exercise all local and safety practices when working with the soldering equipment.*

1. Tin the inner conductor.
2. Heat the center contact with the soldering equipment and carefully push it over the center conductor so that it butts against the dielectric. It should appear as shown in Figure 3.

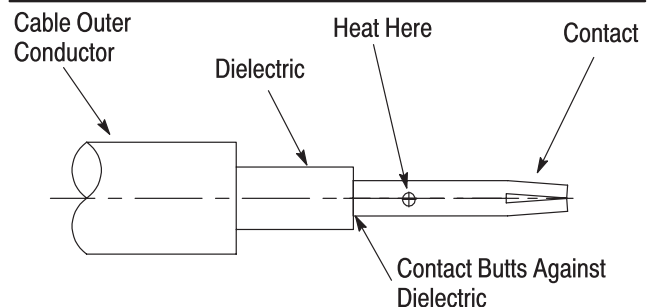

Figure 3

3. Remove excess solder and splatter.

### 3.3. Soldering the Housing Assembly to the Cable

1. Position and secure the housing in a small bench vise.
2. Insert the cable into the housing assembly, and seat it against the inside of the housing.



*To avoid personal injury, exercise all local and safety practices when working with the soldering equipment.*

3. Solder the cable to the housing as shown in Figure 4.
4. Remove excess solder and splatter.

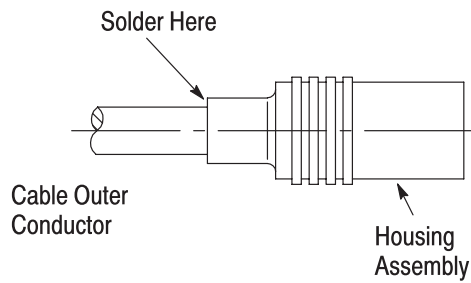

Figure 4

### 3.4. Inspection

Adherence to the previous steps should result in the tolerances shown in Figure 5.

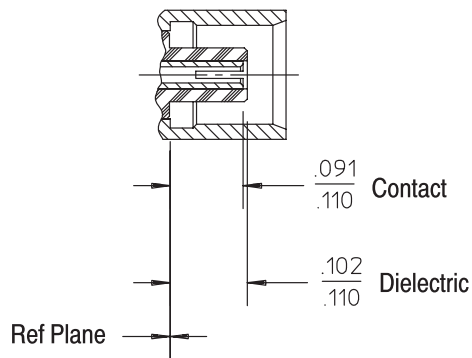

Figure 5

### 4. REVISION SUMMARY

Since the previous release, the following revisions were made:

- Added 1060774-2
- Updated format to current corporate requirements