

2.2. Hermetic Seal Assembly Installation

1. Assemble the appropriate solder preform into the mounting hole.
2. Assemble the hermetic seal assembly into the mounting hole as shown in Figure 4.
3. Thread the hermetic seal soldering fixture into the mounting hole and bottom it.
4. Apply sufficient heat to flow solder.
5. After the solder has cooled, disassemble the hermetic seal soldering fixture.

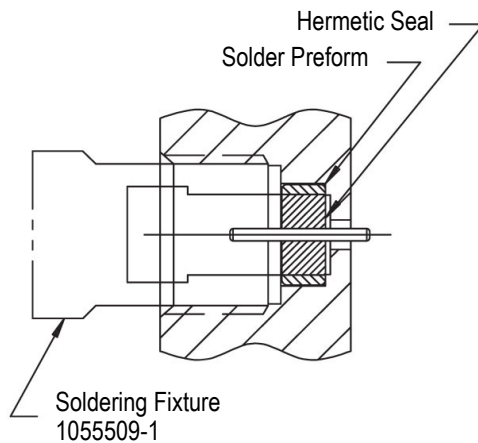

Figure 4

2.3. Connector Installation (Figure 5)

1. Thread the connector into the mounting hole.
2. Using the torque tool (1059773-1), torque the connector to 16-20 in.-lbs.
3. This completes the installation of the connector.

3. REVISION SUMMARY

Since the previous release of this document, the TE logo was applied.

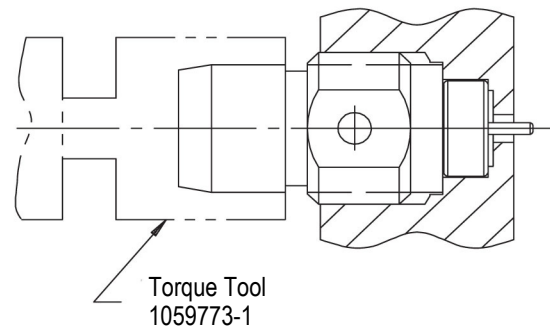

Figure 5