

Figure 1

1. INTRODUCTION

This instruction sheet covers terminating procedure for pivot power RJ45 modular plug connectors. The connectors are designed to be terminated using the insulation piercing technique. These connectors are intended to be used in low voltage (60 V AC/DC maximum) and low-current (1.0 ampere maximum) applications.

i NOTE
This product is intended for indoor use only in communication circuits in an isolated closed loop circuit and not for telecommunication circuits (POTS).

i NOTE
Dimensions in this instruction sheet are in metric units [with U.S. customary units in brackets]. Figures are not drawn to scale.

Reasons for reissue of this instruction sheet are provided in Section 5, REVISION SUMMARY.

2. DESCRIPTION

These connectors are unshielded with 8 mating interface pin positions on 1.02-mm [.040-in.] centerline spacing. The pin positions reduce to 2 common output positions at the cable exit end.

POTS is plain old telephone service.

Each connector contains terminals that terminate to cable having two stranded wires (cable types and sizes are described on the specific connector customer drawing).

Each connector consists of a housing with 2 contacts and a pivot cover. See Figure 1 for features.

3. TERMINATION

- Strip the outer cable jacket as shown in Figure 2, Detail A.
- Position and splay the cable conductors outward as shown in Figure 2, Detail B.

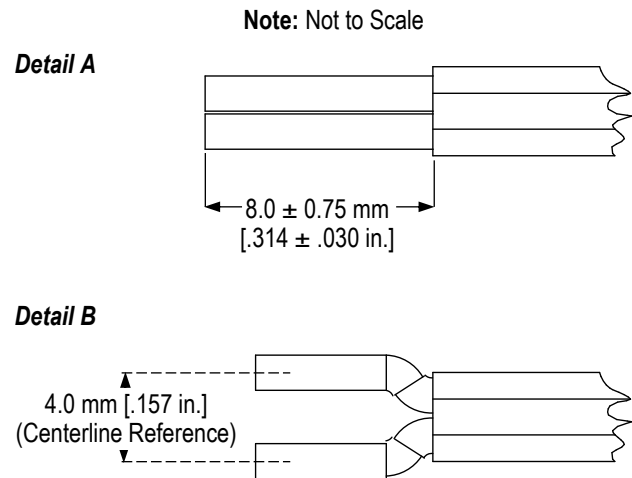

Figure 2

- Ensure that the connector pivot cover is in the open position (see Figure 1) then, align the discrete wires with the discrete wire ports of the connector as follows:
 - Place the odd numbered conductor in the negative (-) discrete wire port and the even numbered conductor in the positive (+) discrete wire port.
 - Insert the cable jacket beyond the strain relief slot of the pivot cover, ensuring that the discrete wires are bottomed on the internal surface of the pivot cover. Refer to Figure 3.

- Using a commonly available (medium sized) hand tool (such as, pliers), pinch the pivot cover toward the housing. See Figure 4.

i NOTE
The parallel jaws of the hand tool should have a closing height of 4 mm [.158 in.] or less.

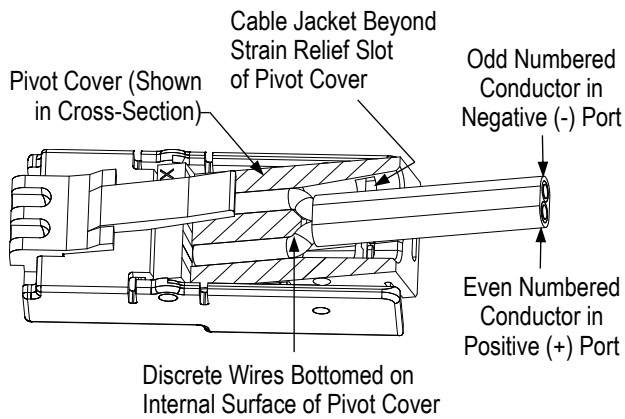

Figure 3

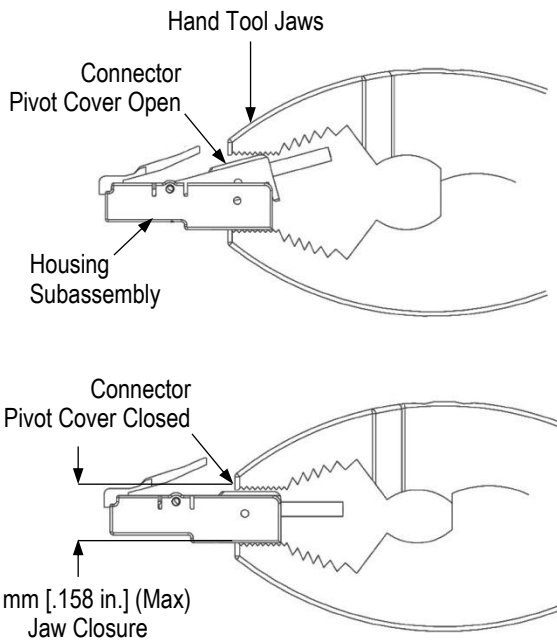

Figure 4



CAUTION
To prevent damage to the connector locking latch, make sure not to pinch the locking latch between the tool jaws.

Inspect the termination to ensure the following:

- the connector cable strain relief is fully engaged with the cable jacket
- the housing latch is visible in the pivot cover latch window, ensuring that the pivot cover is fully closed (refer to Figure 5)



NOTE
For detailed inspection requirements, refer to Application Specification 114-32086.

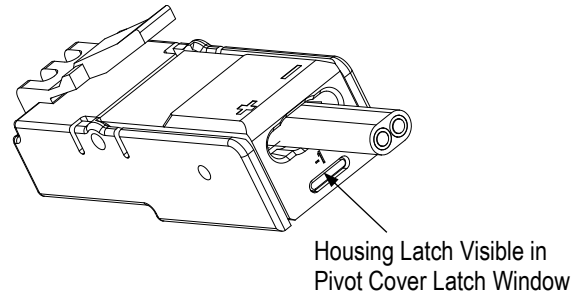

Figure 5

4. REPLACEMENT AND REPAIR

These connectors are not repairable. Do not re-terminate a connector. Cut the connector off of the cable, and replace it with a new connector.

5. REVISION SUMMARY

Revisions to this instruction sheet include:

- Changed name of product
- Added usage description to Section 1
- Added reference to specification to Step 5 of Section 3