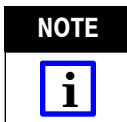

Figure 1

1. INTRODUCTION

SMB 50-ohm (413985-[] and 414946-[]), shown in Figure 1, and 75-ohm (414618-[]) straight cable plug connectors are crimped onto flexible coaxial cable. Cable sizes and applicable tooling for crimping the plugs is listed in Figure 3. For detailed procedures on using the tooling, refer to the instructions packaged with the tooling.

Inline Plug Housing 109756-1, shown in Figure 1, is available to assemble onto Plugs 414946-1 and 1-414946-2 to provide an additional locking mechanism for the mating connector.



Dimensions in this instruction sheet are in millimeters [with inches in brackets]. Figures are not drawn to scale.

Reasons for reissue of this instruction sheet are provided in Section 5, REVISION SUMMARY.

2. DESCRIPTION

The plug consists of a plug body, contact, and ferrule. The housing consists of two identical halves. Each half features a locking tab. See Figure 1.

3. ASSEMBLY PROCEDURE

3.1. Plug

- Slide the ferrule onto the cable. Strip the cable according to the dimensions provided in Figure 2. Be careful not to nick or cut the center conductor or braid. Flare the braid.

Recommended Stripping Dimensions ± 0.25 [± 0.010]

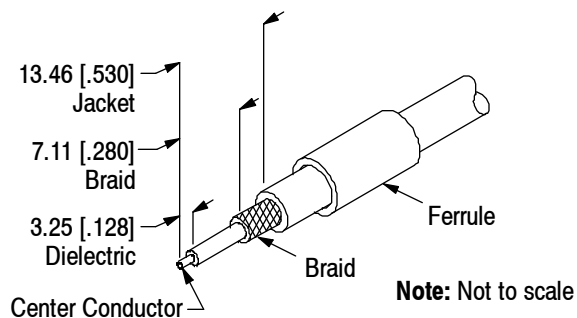

Figure 2

CABLE (RG/U)	TOOLING					
	CONTACT CRIMP		FERRULE CRIMP			
	DMC Crimp Tool AFM8 Military M22520/2-01		PRO-CRIMPER* III Frame Assembly 354940-1		DMC Crimp Tool HX4 Military M22520/5-01	
	Positioner	Selector Setting	Die Assembly	Crimping Chamber Marking	Die Set	Hex Position
178, 196	K699	4	58483-1	.105 (A)	Y-1637	.105
161, 174, 179, 187, 188, 316				.128 (B)		.128
174, 188, 316 (All Double Braid)				.151 (C)		.151

Figure 3

DMC is Daniels Manufacturing Company

2. Slide the contact onto the center conductor of the cable. Crimp the contact with the appropriate tooling and setting (refer to Figure 3).
3. Insert the crimped contact into the plug body as shown in Figure 4, Detail A until it bottoms inside the plug body. Make sure that the cable braid is positioned over the tail-end of the plug body.
4. Slide the ferrule over the cable braid until it is positioned against the shoulder of the plug body. See Figure 4, Detail B.
5. Crimp the ferrule with the appropriate tooling and setting (refer to Figure 2).
6. See Figure 4, Detail C for a properly assembled connector.

Detail A

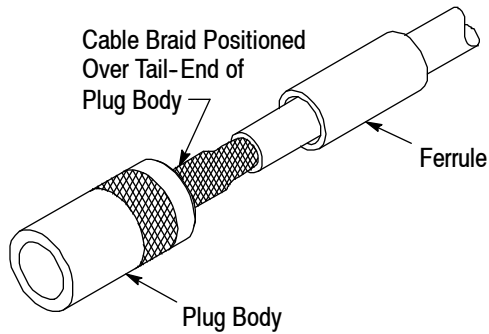

Detail B

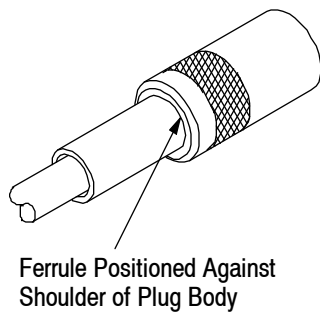

Detail C

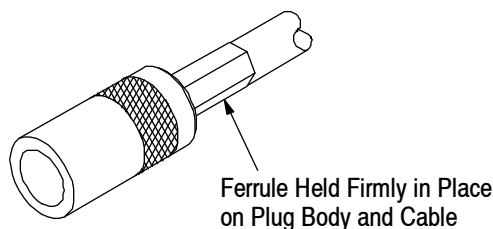
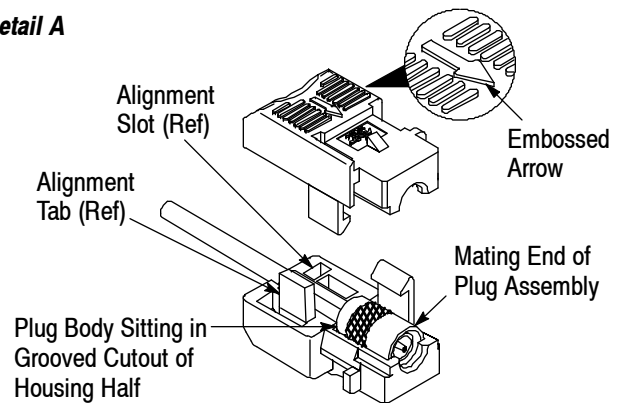

Figure 4

3.2. Housing
(Optional for Plugs 414946-1 and 1-414946-2)

1. Lay the plug assembly in the nest of one half of the housing. Orient the plug so that the mating end is facing in the same direction as the embossed arrow on the outside of the housing. Make sure that the plug body is sitting in the grooved cutout. See Figure 5, Detail A.
2. Fit the housing halves together so that the alignment tabs enter the alignment slots (both halves have one of each). Make sure that the plug assembly is still properly positioned, and squeeze the halves together until the latches (both halves have one) engage the other half. See Figure 5, Detail B.

Detail A



Detail B

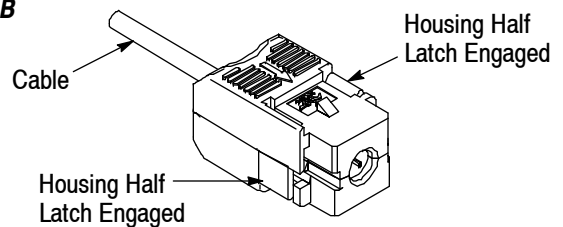

Figure 5

3. Gently push the cable to ensure that the plug assembly is secure in the housing. If the plug assembly moves out of the housing, disengage the latches, re-position the plug assembly, and re-assemble the housing.

4. REPLACEMENT AND REPAIR

The plugs and housings are not repairable. Discard and replace any defective or damaged product. DO NOT re-use a terminated plug by removing the wire.

5. REVISION SUMMARY

Revisions to this instruction sheet include:

- Changed company logo