

\* PURCHASED FROM AMP INCORPORATED (Minimum Length - 500 ft)  
† USED IN AMP-O-ELECTRIC\* MACHINE 565435-5

Fig. 1

NOTE

Strip terminals are supplied in reel form and are intended for high-volume applications. Loose-piece terminals are supplied in individual form and are recommended for maintenance and repair using hand crimping tool.

**1. INTRODUCTION**

This Instruction Sheet (IS) covers AMP Braid-Pic Vertical Disconnect terminals used on printed circuit (pc) boards in conjunction with AMP Miniature Spring Sockets and coaxial cable.

The terminals are designed specifically for applications requiring vertical connection to the pc board with the option of connect/disconnect.

NOTE

All dimensions presented on this instruction sheet are in inches.

**2. DESCRIPTION**

The vertical disconnect Braid-Pic connector assembly, using the solid center conductor of the coaxial cable as the center contact, consists of three basic elements: the Braid-Pic contact with cable support; the vertical pc board disconnect (which is soldered to the pc board and carries the ground circuit from the cable to the pc board); and the AMP miniature spring socket which is also soldered to the pc board and acts as a receptacle contact for the center conductor.

**3. PC BOARD APPLICATION**

Using a pc board of the thickness called out in the chart in Figure 1, proceed as follows:

1. Prepare board by drilling holes as indicated by the dimensions in Figure 2.

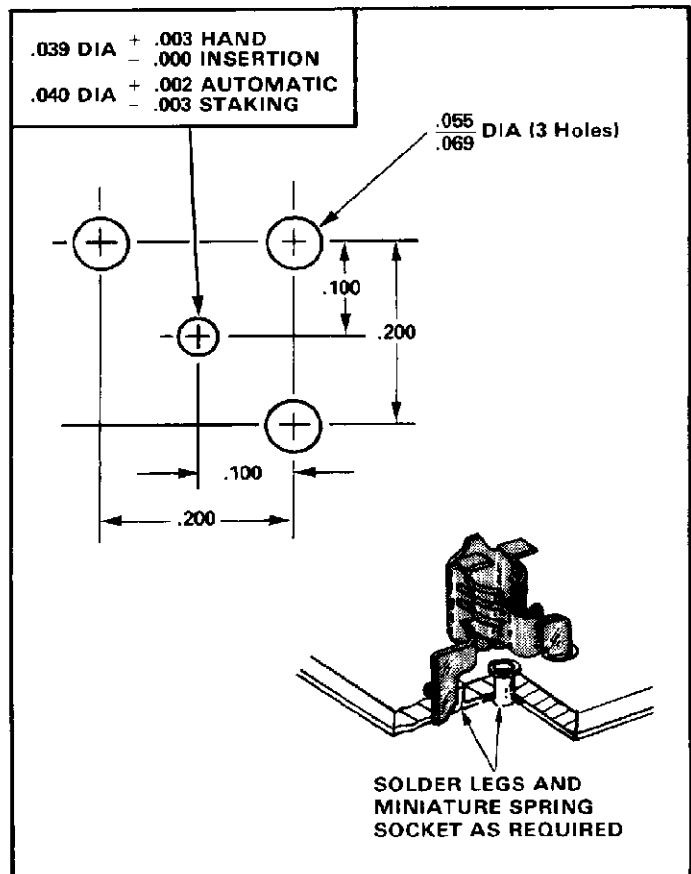

Fig. 2

2. Insert miniature spring socket into the .039-.040 dia hole, and solder as required.
3. Insert legs of disconnect contact into appropriate holes in pc board as described in Figure 2, and solder as required.

Copyright 1978, 1983 by AMP Incorporated, Harrisburg, Pa. All International Rights Reserved. AMP Incorporated products covered by U.S. and Foreign patents and/or patents pending.

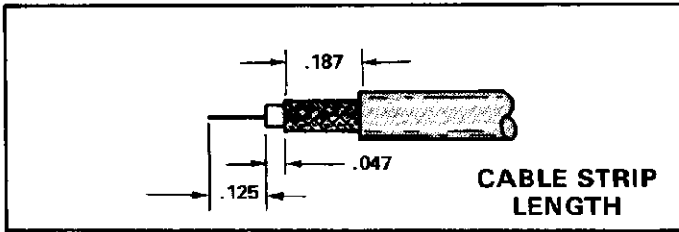

Fig. 3

**4. CABLE CRIMP APPLICATION**

Using cable referred to in Figure 1, proceed as follows:

1. Strip cable to dimensions shown in Figure 3.
2. Place stripped cable in terminal in a straight downward motion until braid is seated on lances in braid barrel and outer insulation is seated into insulation barrel. See Figure 4.
3. Crimp cable in terminal according to procedure packaged with crimping tool.

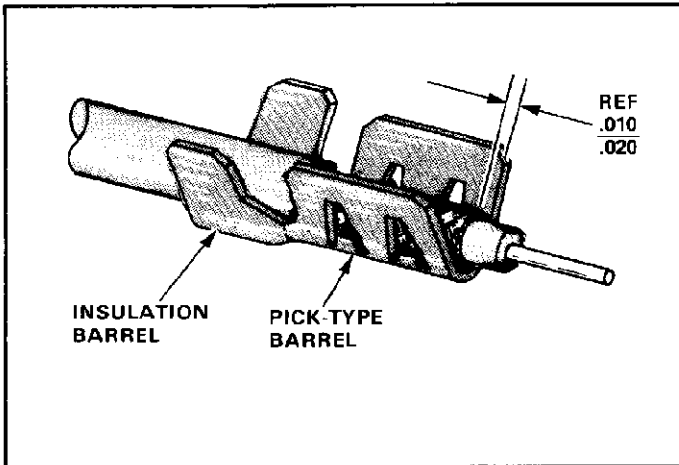

Fig. 4

**AMP PC BOARD VERTICAL DISCONNECT**

4. Insert crimped terminal into pc board disconnect until bottomed, with cable center conductor inserted into miniature spring socket. See Figure 5.

NOTE

*Partial rotation of cable connector will ease mating of parts.*

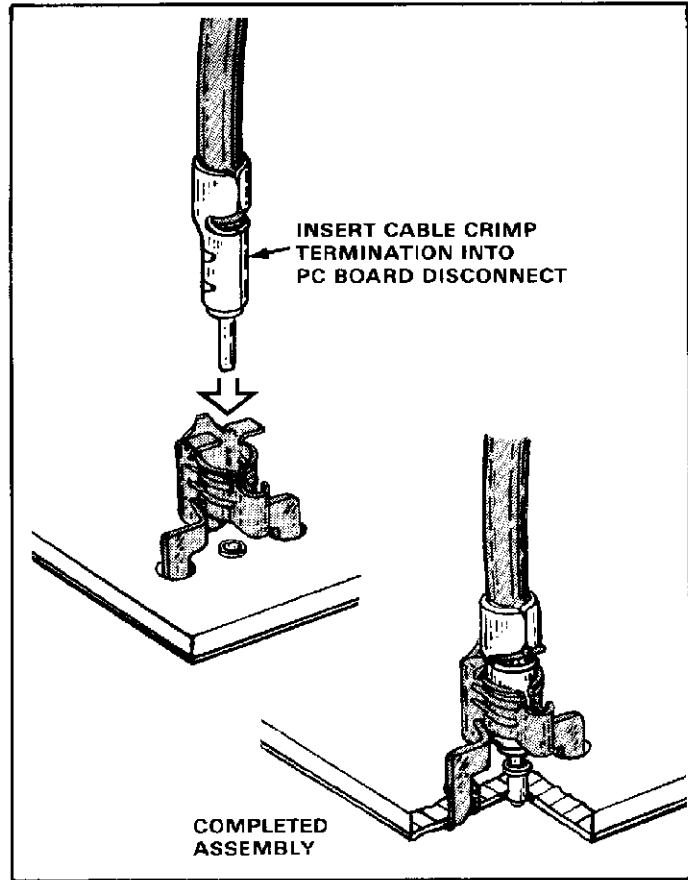

Fig. 5