

NOTE
This type ferrule contains a seal and is used on all weatherproof connectors.

RG/U CABLE	SILVER PLATED PART NO.		CABLE STRIP DIMENSION	CRIMPING TOOL	
	STANDARD PART NO. AND GOVERNMENT DESIGNATION • M39012/	WEATHERPROOF		PART NO.	DOCUMENT
8, 8a, 213	03-0004	225094-2	Figure 5	220015-1	408-2331
9, 9a, 9b, 214	03-0005	225094-1	Figure 4	220015-1	408-2331
MICRODOT 250-9172 250-9208	---	1-225094-4	Figure 5	220015-1	408-2331
MICRODOT 250-9171 250-9207	---	1-225094-5	Figure 5	220015-1	408-2331
RAYCHEM* 5012H3012	---	1996332-1	Figure 6	90740-1	408-4183

●Government designation applies only to silver plated standard parts.

Figure 1

1. INTRODUCTION

The connectors listed in the table in Figure 1 are assembled and crimped as described in Section 2, ASSEMBLY PROCEDURE.

Refer to the table in Figure 1 for related tooling and instruction sheet numbers.

Figure 2 provides instruction sheets containing information on additional Series N Connectors.



All dimensions on this document are in metric units [with U.S. customary units in brackets]. Figures and illustrations are for identification only and are not drawn to scale.

Reasons for reissue are provided in Section 3, REVISION SUMMARY.

CONNECTORS	DOCUMENT
Plugs	408-2028-1
Jacks	408-2028-2
Panel Jacks	408-2028-4
Right-Angle Plugs	408-2028-5

Figure 2

2. ASSEMBLY PROCEDURE (Figure 3)

- Slide ferrule on cable, then strip cable to dimensions provided in Figures 4 thru 6. Do NOT comb braid. Crimp center contact. Refer to tooling instruction sheets referenced in Figure 1.
- Insert contact into the connector with braid over support sleeve. Pull back lightly on the wire to ensure contact is retained by an internal locking force established between the connector dielectric and the center contact.

NOTE
 The design of parts for smaller cables (RG 55, 58, 141, and 142) allows the center contact to pass beyond the internal locking feature if it is inserted with too much force. Pull back on the wire to properly locate and retain the contact in the locking feature if this condition has occurred.

3. Slide ferrule over braid and crimp ferrule. Refer to tooling instruction sheets referenced in Figure 1.

NOTE
 When terminating part to cables less than 304.8 mm [12 in.] in length, care must be taken to prevent the cable dielectric from moving inside the cable jacket during crimping. Failure to prevent this movement could lead to DWV failures. When short cable lengths are required, it is recommended to use a 304.8 mm [12 in.] length of cable and trim cable to final length after crimping part onto cable.

3. REVISION SUMMARY

- Updated document to corporate requirements
- Added NOTE to Paragraph 2.3
- Deleted obsolete document in Figure 2

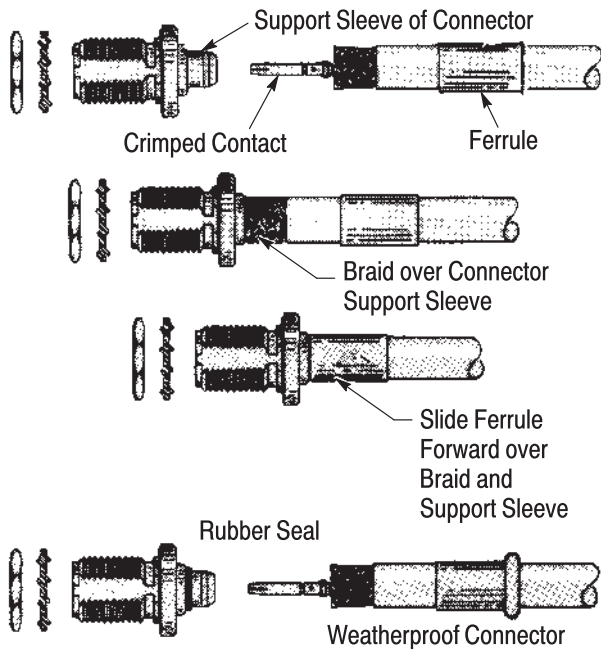

Figure 3

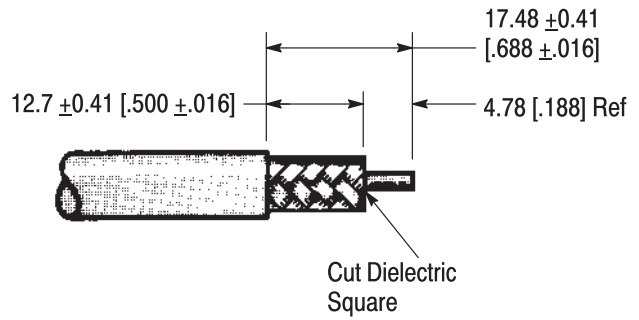

Figure 4

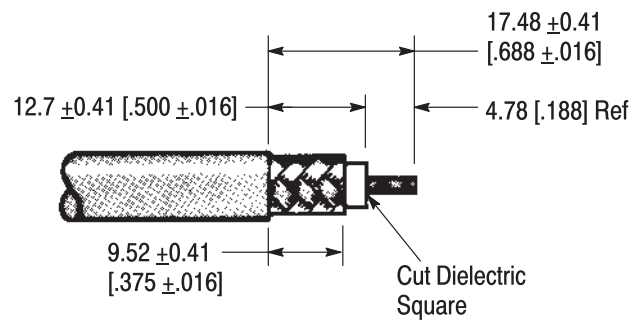

Figure 5

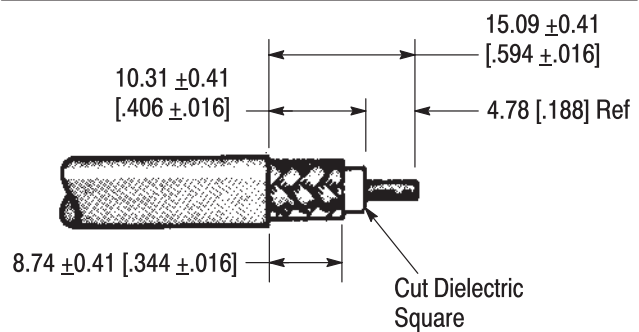

Figure 6