

TECK-530 Series  
5kV Class (Unshielded)

Splice for 3/C Armored Teck  
Power Cables

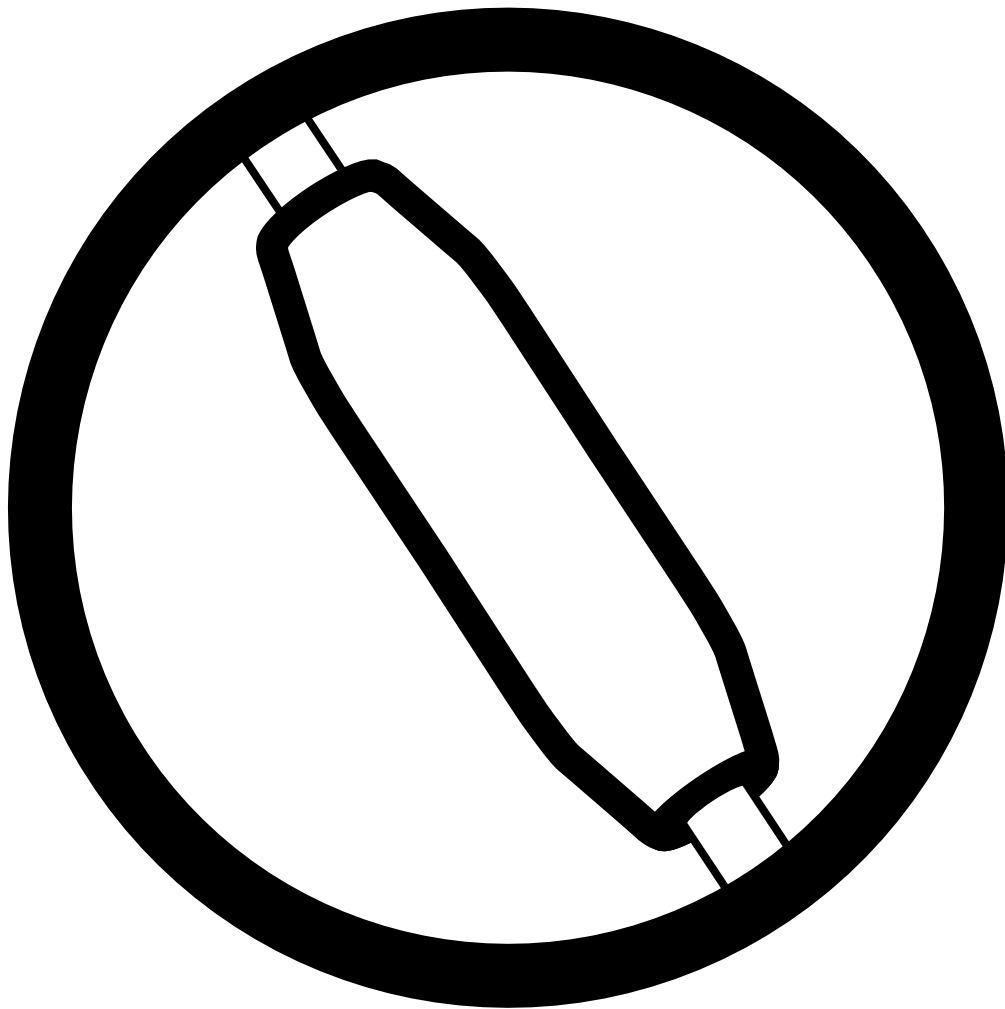

## General Instructions

The following items should be included in these kits:

### TECK-531

- 3 Stress Relief Mastic sealing strips, 24" (610mm) long, yellow
- 3 Connector insulating Sleeves, 6" (150mm) long, red
- 3 Connector Sealing Sleeves, 10" (255mm) long, black
- 1 Protection Sleeve for Ground Connector, 4" (100mm) long, green
- 1 Inner Jacket Sealing Sleeve, 30" (760mm) long
- 1 Outer Jacket Wraparound Sealing Sleeve, 40" (1000mm) long, closure channels and clip
- 1 Strip of Tinned Copper Braid, 3/4" (20mm) wide and 36" (915mm) long
- 2 Ground Clamp Springs
- 1 Strip of Abrasive Cloth
- 2 Rolls of Tinned Copper Mesh, 15 ft. (4570mm) long

### TECK-532

- 3 Stress Relief Mastic sealing strips, 24" (610mm) long, yellow
- 3 Connector insulating Sleeves, 8" (205mm) long, red
- 3 Connector Sealing Sleeves, 12" (305mm) long, black
- 1 Protection Sleeve for Ground Connector, 4" (100mm) long, green
- 1 Inner Jacket Sealing Sleeve, 35" (900mm) long
- 1 Outer Jacket Wraparound Sealing Sleeve, 48" (1220mm) long, closure channels and clip
- 1 Strip of Tinned Copper Braid, 1.10" (30mm) wide and 40" (1000mm) long
- 2 Ground Clamp Springs
- 1 Strip of Abrasive Cloth
- 2 Rolls of Tinned Copper Mesh, 15 ft. (4570mm) long

**Note:** Connectors are not included as each kit covers a range of cable sizes.

## General Instructions

### Suggested Installation Equipment (not supplied with kit)

- Cable preparation tools
- Clean, lint-free cloths
- Connector(s) and installation tools
- Raychem P63 cable preparation kit or cable manufacturer approved solvent
- Electrician's tape
- Raychem recommended torch

### Recommended Raychem Torches

Install heat-shrinkable cable accessories with a "clean burning" torch, i.e., a propane torch that does not deposit conductive contaminants on the product.

Clean burning torches include the Raychem FH-2629 (uses refillable propane cylinders) and FH-2616A1 (uses disposable cylinder).

### Safety Instructions

**Warning:** When installing electrical power system accessories, failure to follow applicable personal safety requirements and written installation instructions could result in fire or explosion and serious or fatal injuries.

To avoid risk of accidental fire or explosion when using gas torches, always check all connections for leaks before igniting the torch and follow the torch manufacturer's safety instructions.

To minimize any effect of fumes produced during installation, always provide good ventilation of confined work spaces.

*As Raychem has no control over field conditions which influence product installation, it is understood that the user must take this into account and apply his own experience and expertise when installing product.*

### Adjusting the Torch

Adjust regulator and torch as required to provide an overall 12- inch bushy flame. The FH-2629 will be all blue, the other

torches will have a 3- to 4-inch yellow tip. Use the yellow tip for shrinking.

### Regulator Pressure

FH-2616A1	Full pressure
FH-2629	15 psig

### Cleaning the Cable

Use an approved solvent, such as the one supplied in the P63 Cable Prep Kit, to clean the cable. Be sure to follow the manufacturer's instructions. Failure to follow these instructions could lead to product failure.

Some newer solvents do not evaporate quickly and need to be removed with a clean, lint-free cloth. Failure to do so could change the volume resistivity of the substrate or leave a residue on the surface.

Please follow the manufacturer's instructions carefully.

### General Shrinking Instructions

- Apply outer 3- to 4-inch tip of the flame to heat-shrinkable material with a rapid brushing motion.
- Keep flame moving to avoid scorching.
- Unless otherwise instructed, start shrinking tube at center, working flame around all sides of the tube to apply uniform heat.

To determine if a tube has completely recovered, look for the following, especially on the back and underside of the tube:

1. Uniform wall thickness.
2. Conformance to substrate.
3. No flat spots or chill marks.
4. Visible sealant flow if the tube is coated.

**Note:** When installing multiple tubes, make sure that the surface of the last tube is still warm before positioning and shrinking the next tube. If installed tube has cooled, re-heat the entire surface.

# Installation Instructions

**Table 1**

Kit	Nominal Conductor Range	Insulation Dia. Range	Inner Jacket Dia. Range	Outer Jacket Dia. Range	Maximum Connector Length	Splice Installed Length
TECK-531	#2-4/0 AWG	0.40-0.75" (10-20mm)	1.20-2.00" (30-50mm)	1.50-2.40" (40-60mm)	3.50" (90mm)	40" (1015mm)
TECK-532	250-750 MCM	0.65-1.20" (15-30mm)	1.80-3.00" (45-75mm)	2.20-3.25" (55-85mm)	6.00" (150mm)	48" (1220mm)

**Table 2**

Kit	Outer Jacket Cutback A	Outer Jacket Cutback B	Maximum Connector Length	Expansion Gap Z
TECK-531	22" (560mm)	12" (305mm)	3.50" (90mm)	0.25" (5mm)
TECK-532	25" (635mm)	15" (380mm)	6.00" (150mm)	0.50" (15mm)

**1. Prepare cables.**

To allow ground wires to be connected at a later stage of the splice, overlap the cables by 3.0" (75mm) and mark a reference line in the middle of the overlap.

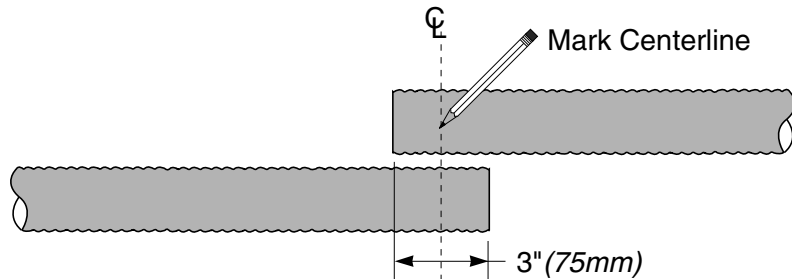

201

**2. Cut back jackets and armour.**

Measuring from the reference line, remove the outer jacket, armour and inner jacket to the dimensions given in Table 2.

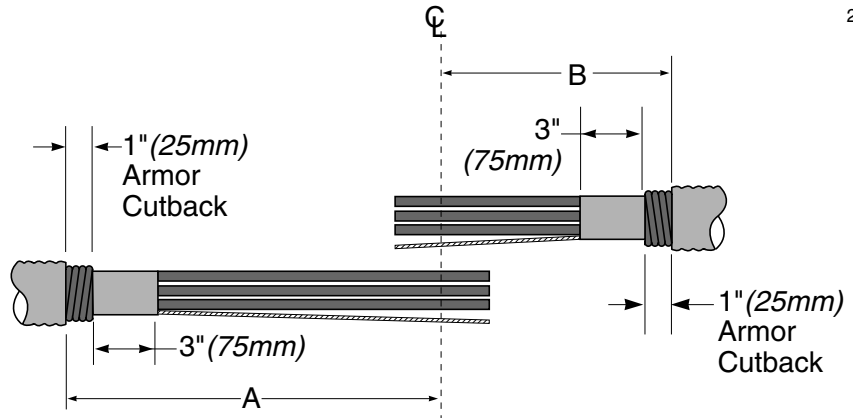

202

**3. Remark reference line and cut conductors.**

Remark the reference line on the cable conductors and cut the conductors at the mark.

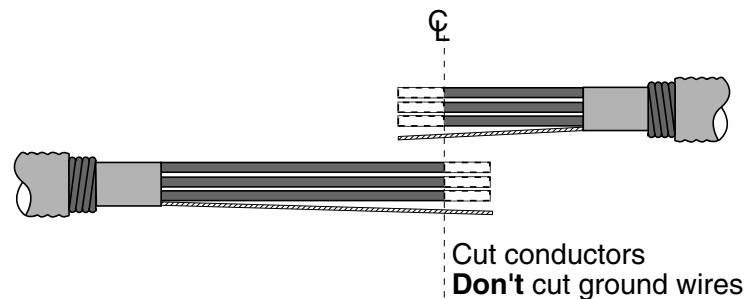

203

## Installation Instructions

### 4. Position sleeves.

Slide the large black Inner Jacket Sealing Sleeve over one cable end. Telescope the red Connector Insulating Sleeves into the black Sealing Sleeves and place one set over each long conductor.

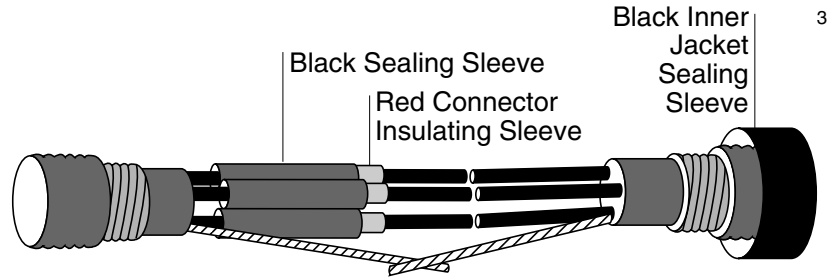

### 5. Install connectors; apply Stress Relief Mastic (SRM).

Install connectors using the correct crimping tool and remove sharp edges. Remove the indicated backing strip from one side of a *long strip* of SRM. Roll the SRM and remaining backing strip into a convenient size. Removing the remaining backing strip, tightly wrap the SRM around the connector and exposed conductor. Be sure to fill the gaps and low spots around the connector. Continue onto the insulation for 1/4" (5mm) on both sides of the connector. Apply sufficient SRM to build up the diameter over the connector area to equal that of the insulation. If the diameter of the connector exceeds that of the insulation, one layer of the mastic is sufficient.

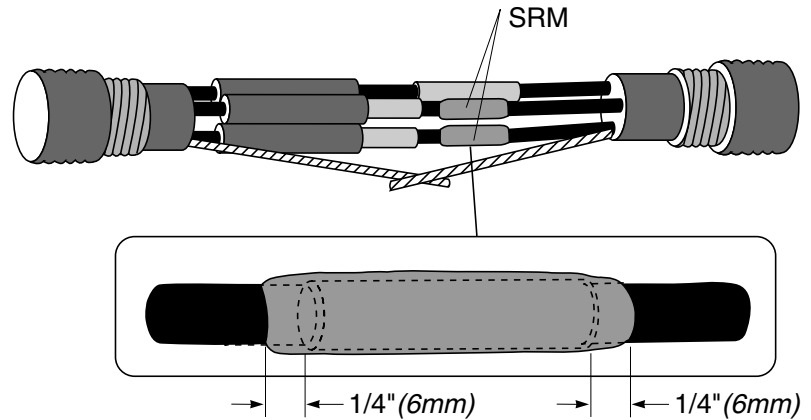

**NOTE: Center a red Insulating Sleeve over each completed connector to keep it clean before starting to apply the SRM to the next connector.**

### 6. Position sleeves; shrink.

Ensure that all three Connector Insulating Sleeves are positioned centrally over each connector and shrink them down using a soft yellow (clean burning) propane flame. Center the three Connector Sealing Sleeves over the Insulating Sleeves and shrink them down. Slide the green Protection Sleeve over one of the ground wires. Cut the ground wires to butt and install connector. Shrink the Protection Sleeve over the connector.

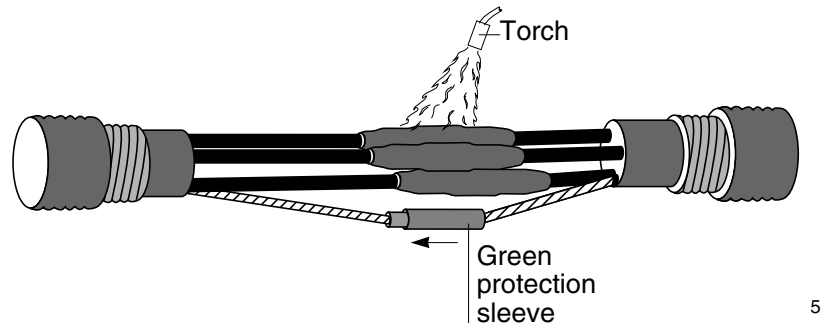

### 7. Position inner jacket sealing sleeve; shrink in place.

Slide the inner jacket sealing sleeve over the splice area so it overlaps the inner jacket at each end and shrink it into place.

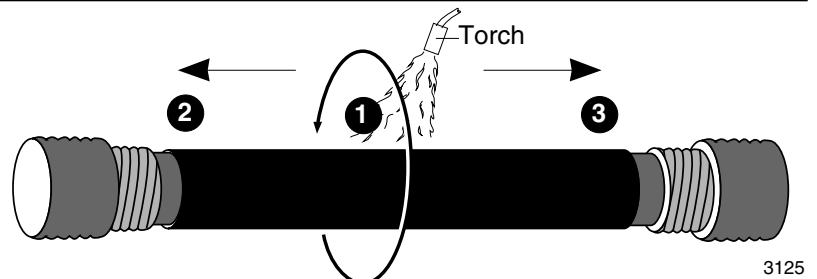

**8. Connect ground braid.**

Connect the tinned copper braid to the armor using the ground clamp springs provided. (1) Flare one end of the ground braid and place it onto the armour butted up to the cable jacket. (2) Attach the braid to the shield by placing two wraps of the spring clamp over the braid. (3) Fold the braid back over the spring clamp wraps. Continue to wrap the remaining clamp over the braid. Tighten clamp by twisting it in the direction it is wrapped and secure with copper foil tape provided.

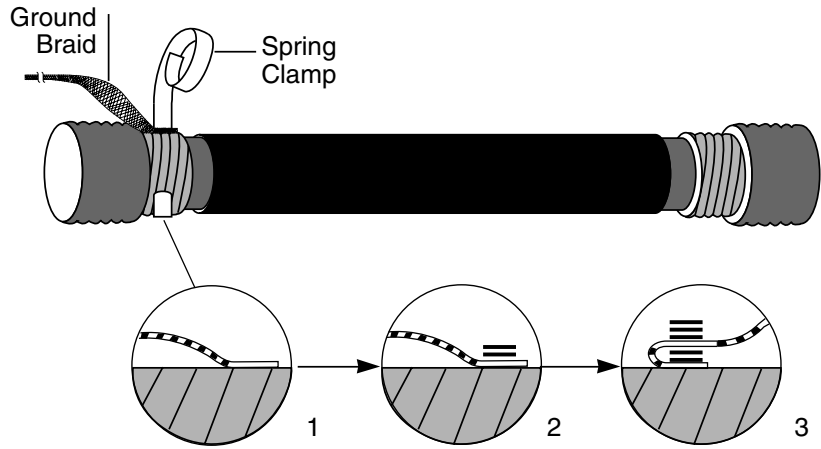

3126

(4) Lay the braid across the splice tube and onto the exposed armour on the other side. (5) Make two wraps of the clamp over the braid. (6) Fold the braid back toward the splice and finish wrapping the clamp. Tighten and secure. Cut off excess braid.

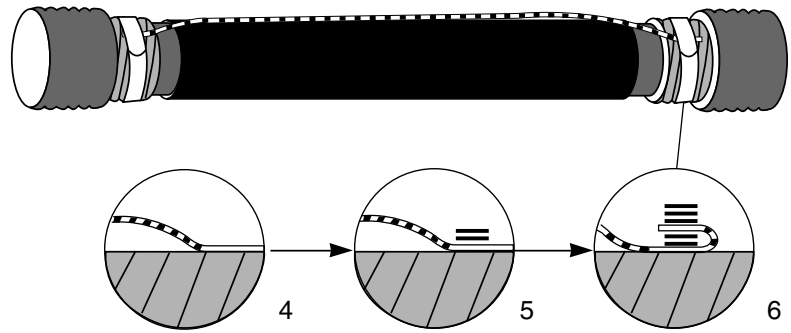

3045

**9. Apply copper mesh.**

Starting at the outer jacket cutback on one side, wrap the tinned copper mesh over the splice and tie off at the jacket cutback on the opposite side.

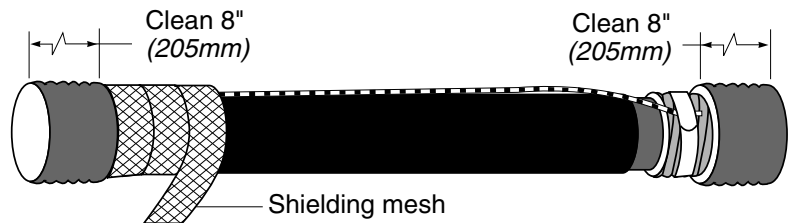

3128

**10. Position wraparound sleeve.**

Remove or tape over all sharp points to prevent puncture of wraparound sleeve. Remove backing from the wraparound sealing sleeve and center sleeve over splice. Slide metal channels onto the butted rails.

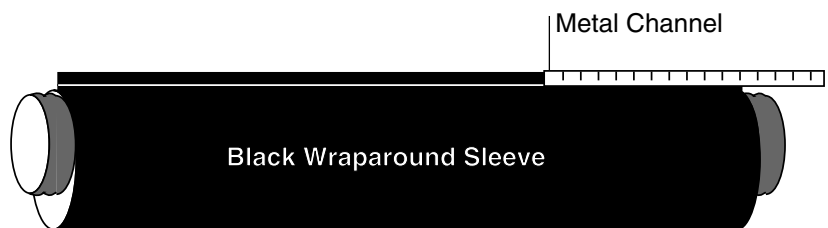

3129

## 11. Install channel clip.

If two channels are used, connect the channels with the short channel retention clip. Use pliers to install clip.

**Note:** Channel(s) must overlap sleeve edge by 1/4 inch (5mm) minimum.

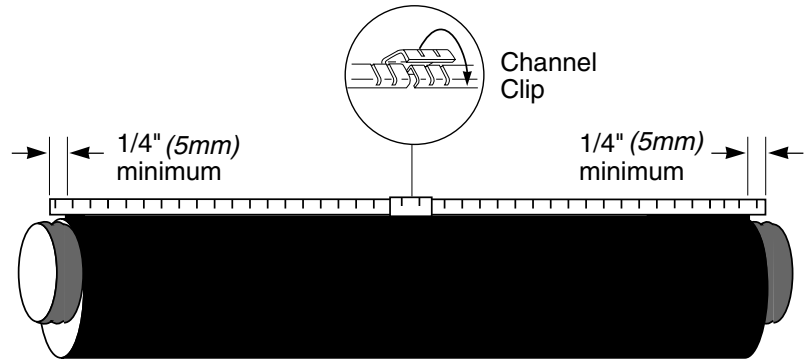

3130

## 12. Shrink the wraparound sleeve.

Preheat evenly along both sides of the rail/channel area until this area begins to shrink.

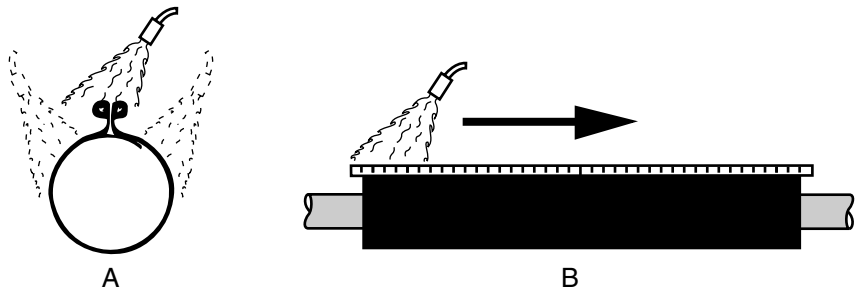

Begin at the center and work toward each end. Post-heat the entire sleeve (concentrating on metal channel area) for 30 seconds after completely shrunk.

**Splice is complete.**

**Note:** Allow to cool before moving or placing in service.

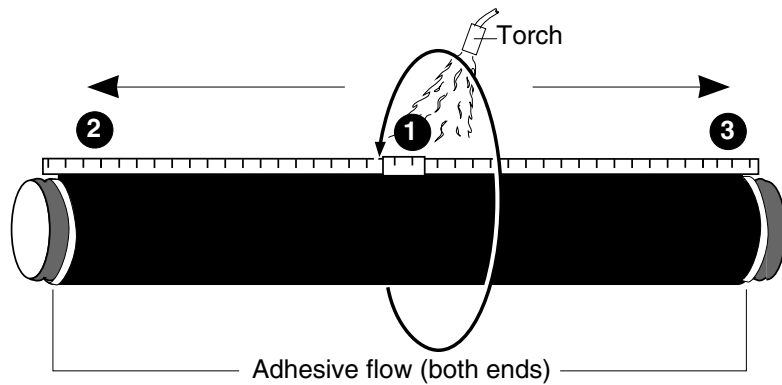

3131