



AMP INCORPORATED
HARRISBURG, PENNA.

A-MP* STRAIN RELIEF CLAMPS
CATALOG NOS. 201221-□ & 201688-□
FOR A-MP SERIES "M" AND
MINIATURE DUALATCH* CONNECTORS

IS 1322	
RELEASED	4-16-62
REVISED	4-23-65

CONNECTOR PRODUCTS DIVISION

1. These Strain Relief Clamps (see Figure 1), when attached to a 104 Position Series "M" Connector Block or a 132 Position Miniature DUALATCH Block, relieve strain on the Contacts caused by the weight of free-hanging Wires.

2. ASSEMBLY INSTRUCTIONS

- (a) Attach Strain Relief Bracket to Connector Block using:
- (1) Two #6-32 Screws with Nuts and Lockwashers.
 - (2) A-MP Corner Guide Pins and/or Sockets. See AMP Instruction Sheet No. 7164 or 7178 for selection of A-MP

Guide Pins and/or Sockets.

(b) Bundle Wires to pass thru "U"-Clamp.

(c) Assemble "U"-Clamp, Protective Sleeves, Clamp Plate and "U"-Clamp Nuts to Strain Relief Bracket. Do not tighten Nuts.

(d) Allow a little slack in Wires between "U"-Clamp and Connector Block.

(e) Tighten "U"-Clamp Nuts.

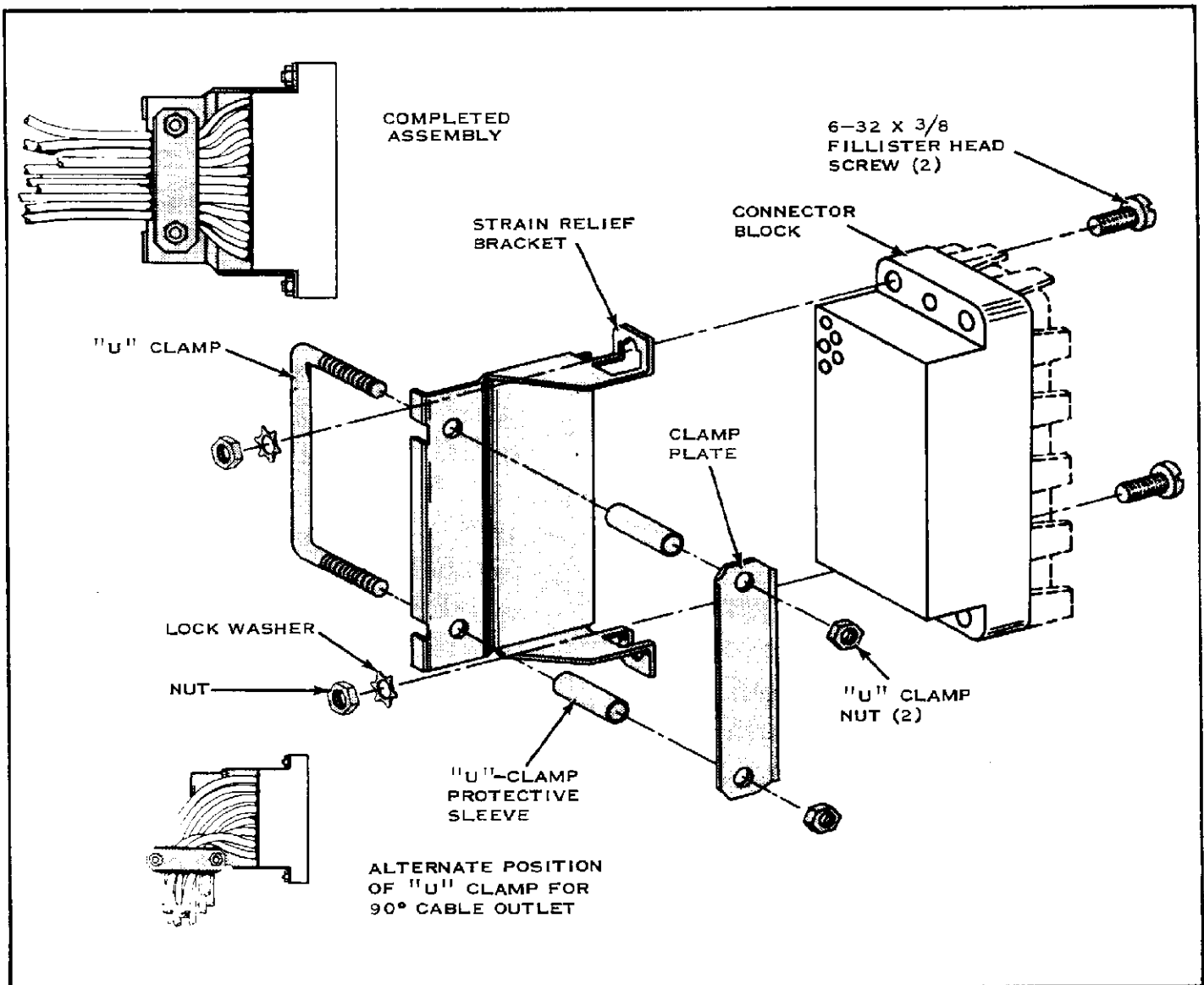

FIG. 1

© 1962, 1965 by AMP Incorporated. All international rights reserved. A-MP® products covered by U. S. and foreign patents and/or patents pending.