

Figure 1

1. INTRODUCTION

This instruction sheet covers assembling the terminated contact, housing, and optional break-away retainer shown in Figure 1, and extracting the contacts from the housing. The optional break-away retainer is designed to be non-removable.

2. DESCRIPTION

The contact features a locking lance that latches onto the locking finger inside of the housing.

The housing is available in 2 through 12 positions. The optional break-away retainer is available in 20 positions. The breakaway retainer is used to prevent the contacts from backing out of or being removed from the housing.

Each section (position) of the break-away retainer fits into a housing contact cavity. The break-away retainer can be installed onto one housing or across two stacked housings. Sections of the break-away retainer can be removed to accommodate less than 20 contact cavities. When installed, the locking slots of the break-away retainer snap onto the locking tabs of the housing.

3. ASSEMBLY

1. Ensure that the contact is properly terminated to the wire according to Application Specification 114-1021.
2. Insert the terminated contact into the housing as follows:
 - a. Check that the locking lance of the contact is not depressed as shown in Figure 1.
 - b. Grasp the contact directly behind the insulation barrel (not the wire), and align the locking lance with the bottom (side opposite the locking tab) of the contact cavity. Make sure that the contact is perpendicular (not at an angle) to the contact cavity. See Figure 2.

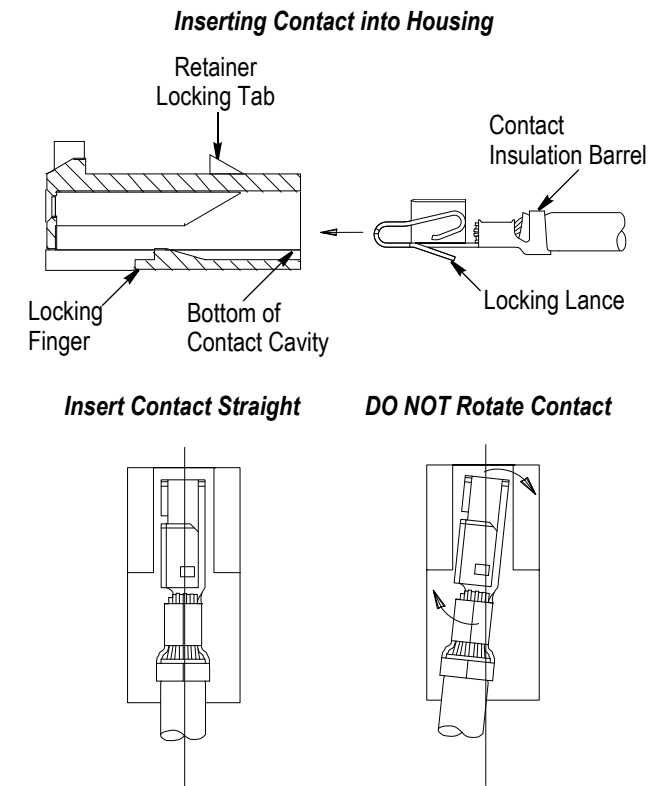

Figure 2



CAUTION Never insert the contact upside down; otherwise, the locking lance could be depressed and cause it to not latch properly onto the locking finger inside of the housing.

- c. Insert the contact straight and not rotated into the contact cavity. If it is not, damage to the contact will occur or the contact will not latch properly onto the locking finger inside of the housing. See Figure 2. Do not force the contact into the housing.

3. If desired, install the optional break-away retainer onto the housing as follows:



The contacts will not be able to be extracted with the break-away retainer installed. To avoid damage to the break-away retainer or housing, do not attempt to remove the retainer.

a. If necessary, break off sections (positions) of the retainer as shown in Figure 3. Make sure that the intended amount of sections are rotated as the sections break off easily.

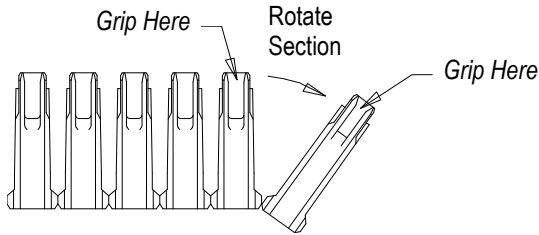

Figure 3

b. Align the retainer with the housing so that the ends of the locking slots face the retainer locking tabs of the housing and the long legs of the retainer are on top of the wires. See Figure 4, Detail A.

c. Slide the break-away retainer onto the housing evenly until the locking slots lock onto the retainer locking tabs of the housing. There will be an audible "click". See Figure 4, Detail B.

Installing Optional Break-Away Retainer

Detail A

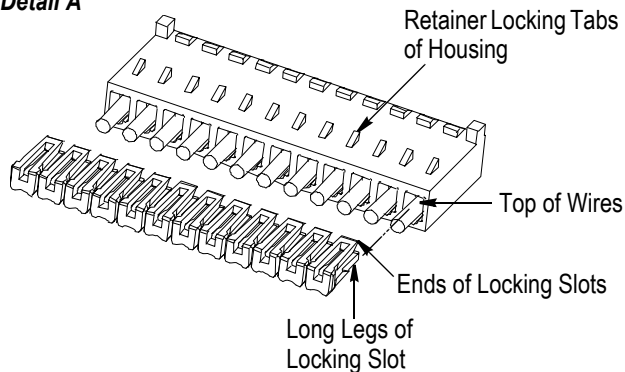

Detail B

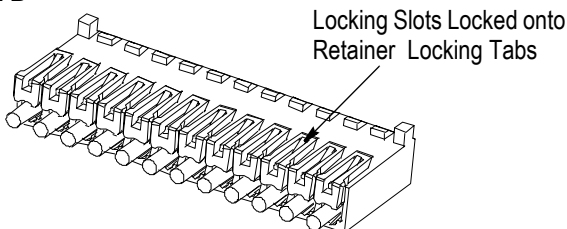

Figure 4

4. DISASSEMBLY

Extract the contacts from the housing using Extraction Tool 90471-1 as follows:



To avoid damage to the contact or housing, never use other tools such as an ice pick, razor knife, mechanical pencil, or paper clip to extract contacts.

1. Position the tool as shown in Figure 5, and insert the tip straight into the housing locking lance slot of the contact cavity of the contact to be extracted until the tool stop bottoms on the housing.
2. Grasp the wire of the contact being extracted, and pull the contact straight out of the housing.
3. Remove the tool.

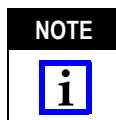

DO NOT re-insert any extracted contacts.

Extracting Contacts from Housing

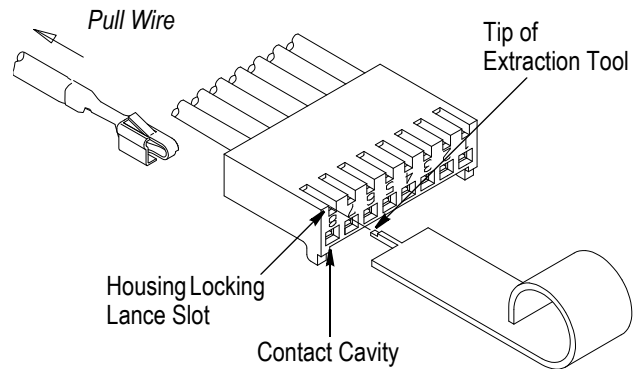

Figure 5

5. REPLACEMENT AND REPAIR

DO NOT use defective or damaged products. Contacts, housings, and optional break-away retainer are not repairable.

6. REVISION SUMMARY

Initial release of instruction sheet