

Figure 1

1. INTRODUCTION

Low-Power Light Engine Assemblies 2008876-[], 2008877-[], and 2008878-[] are used to project a band of light along the entire length of a light pipe with one or more light emitting diodes (LED).

NOTE



All numerical values in this instruction sheet are in metric units [with U.S. customary units in brackets]. Dimensions are in millimeters [and inches]. Figures are not drawn to scale.

The engine assembly is available with a regulated direct current (DC) input (7 through 27 VDC) constant current drive or non-regulated DC input (5 VDC) resistor drive.

The input connection accepts 2-position Common Termination (CT) Connector 2058077-1 (available separately). These engine assemblies only work with AMP LIGHT GUIDES* Light Pipes 2058295-[] (refer to instruction sheet 408-10297 for detailed information).

2. DESCRIPTION

The engine assembly consists of a circuitry housing that contains a printed circuit (pc) board assembly (includes LED and 1/2-watt LED constant current driver circuitry) and a light pipe housing. The engine assembly is available with or without an optical-grade clear acrylic light pipe.

The light pipe housing features slots that allow the light pipe to be installed in one of four orientations so that the light beam emits in one of four directions. The light emitted from the light pipe has a viewing angle of approximately 30 degrees (50% relative intensity) with a 180-degree radial direction from the reflector strip. The vents of the light pipe housing provide adequate cooling for the LED; therefore, heat sink or forced air cooling is not required.

3. ASSEMBLY

CAUTION



The engine assembly supports a 1/2-watt of input to the LED without using forced air cooling or additional heat sink AS LONG AS the vents are free to ambient air circulation. IT IS IMPORTANT that the thermal management is adequate for the LED.

1. Insert the light pipe into the light pipe housing until it contacts the LED lens. Ensure that the reflector strip is in the desired orientation (the output light beam will be directed opposite the reflector strip). See Figure 2.

CAUTION



Caution must be used when inserting the light pipe into the light pipe housing. Excessive force could damage the lens of the LED.

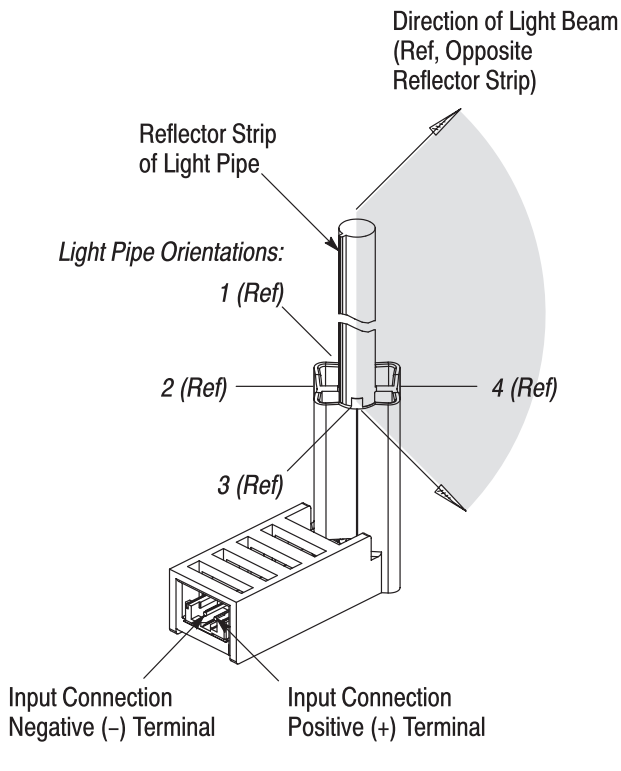

Figure 2

2. Mount the engine assembly by using appropriately-sized pipe clamps attached to the light pipe housing or the circuitry housing (refer to Figure 3) or securing double-sided foam tape to the sides (without the vents) of the circuitry housing.

DIAMETER OF LIGHT PIPE HOUSING	PIPE CLAMP SIZE	
	For Light Pipe Housing	For Circuitry Housing
5 mm	3/8-in.	5/8-in.
10 mm	3/16-in.	

Figure 3

Ensure the following:

— the vents of the light pipe housing are free from obstruction for ambient air circulation



Obstructive air vents will cause inadequate cooling for the LED.

— the mounting scheme has minimal contact possible with the light pipe to prevent light loss (any object that touches the light pipe will cause some light loss)

3. Insert the CT connector into the input connection using correct polarity. Refer to Figure 2.



Correct polarity must be observed. Reverse polarity will permanently damage the LED driver.



For detailed application and inspection requirements, refer to Application Specification 114-13241.

4. REPLACEMENT AND REPAIR

The engine assemblies are not repairable. DO NOT use damaged or defective product.

Order product through your representative, or call 1-800-526-5142, or send a facsimile of your purchase order to 717-986-7605, or write to:

CUSTOMER SERVICE (038-035)
 TYCO ELECTRONICS CORPORATION
 PO BOX 3608
 HARRISBURG PA 17105-3608

5. REVISION SUMMARY

- Initial release of instruction sheet