

Figure 1

1. INTRODUCTION

Crimping Heads 1-48070-0, 1-49512-0, and 1-49513-0 are designed to crimp DIAMOND GRIP Terminals and Splices onto wire size 26-14 AWG. Refer to Figure 2. The crimping heads are used with Double Action Battery Powered Hand Tool Kits 1213804-[].

NOTE *The crimping heads can also be used with the 626 Double Action Pneumatic Tool Adapter 1213563-1.*

This instruction sheet provides recommended procedures for wire preparation, crimping head installation, crimping, and maintenance and inspection. For information concerning tool setup and operation, refer to Customer Manual 409-10056 packaged with the battery tool kit.

NOTE *Dimensions are in metric units with [inches in brackets]. Figures and illustrations are for reference only and are not drawn to scale.*

Reasons for reissue are provided in Section 8, REVISION SUMMARY.

2. DESCRIPTION

The crimping head consists of integral jaws which close in an arc-like motion. After an operator locates the terminal or splice between the crimping jaws and inserts the stripped wire, the tool is activated to crimp the terminal or splice to the wire.

3. HEAD INSTALLATION AND REMOVAL

NOTE *Crimping heads are coated with a preservative to prevent rust and corrosion. Wipe this preservative from the head, particularly from the crimping surfaces.*

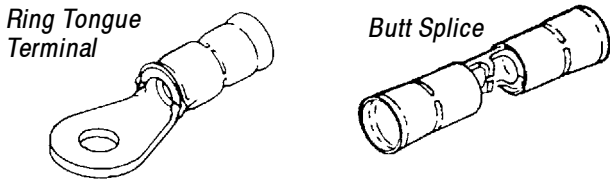

TOOL NO. (Normal Insulation Support)	WIRE SIZE (AWG)	WIRE STRIP LENGTH			
		TERMINALS		SPICES	
		MIN.	MAX.	MIN.	MAX.
1-48070-0	26-22	3.18 [.125]	3.96 [.156]	3.58 [.141]	4.37 [.172]
1-49512-0	22-16	4.37 [.172]	5.16 [.203]	5.16 [.203]	5.94 [.234]
1-49513-0	16-14	4.37 [.172]	5.16 [.203]	5.16 [.203]	5.94 [.234]

Figure 2

3.1. Installation

DANGER To avoid personal injury, be sure to exercise extreme caution when handling the crimp tool. Avoid accidentally depressing the trigger control when installing or removing crimp heads.

DANGER DO NOT operate the battery tool without the proper crimping head installed. After crimping head is installed, make sure that the quick pins are properly inserted to avoid personal injury and damage to the tool.

1. Remove quick pins from the adapter assembly. Refer to Figure 1.
2. Insert crimping head into the adapter assembly.
3. After the crimping head is properly aligned, insert the quick pins through the two holes in the adapter and through the holes in the crimp head.

NOTE The quick pins will “snap” into position when they are properly inserted.

3.2. Removal

DANGER To avoid personal injury, ALWAYS disconnect the battery from the tool before removing crimping head.

Remove the quick pins from the crimping head; then remove the crimping head from the tool holder.

4. CRIMPING PROCEDURES

DANGER To avoid personal injury, ALWAYS keep fingers clear of crimping jaws when operating the tool. Never place anything within the crimping jaws except Tyco Electronics terminals or splices.

4.1. Terminal Crimping Procedure

1. Strip wire to dimensions shown in Figure 2. DO NOT nick wire strand or use wires with nicked or missing conductor strands.
2. Center the terminal or splice wire barrel in the appropriate crimp chamber. See Figure 3
3. Depress the trigger to advance the moving ram. This closes the crimp jaws in order to hold the terminal in place. DO NOT deform the wire barrel.
4. Insert stripped wire into terminal until the end of the conductor butts against the locator as shown in Figure 3.
5. Activate the tool to complete the crimp. The crimp tool automatically returns to the first position of the cycle when the crimp is complete.
6. Refer to Section 5 and Figure 6 for crimp inspection.

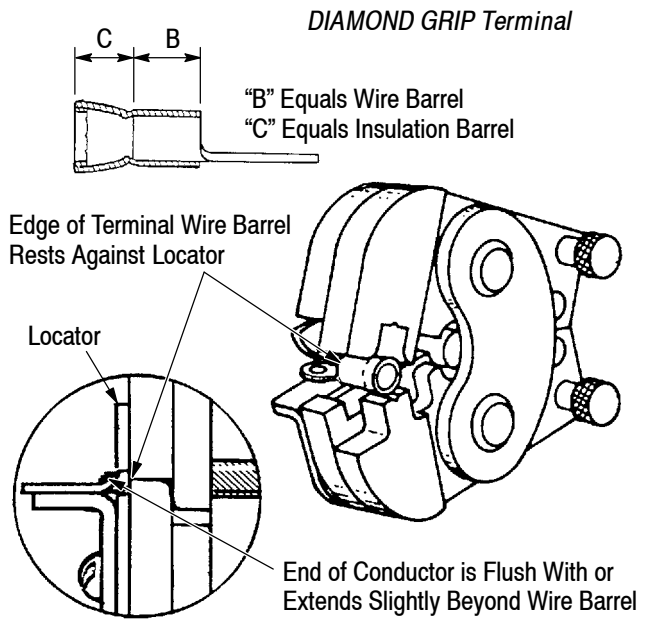

Figure 3

4.2. Butt Splice Crimping Procedure

1. Strip wire to dimensions shown in Figure 2. DO NOT nick wire strand or use wires with nicked or missing conductor strands.
2. Position splice between crimping jaws so that the edge of the splice window rests against the locator. Refer to Figure 4.
3. Depress the trigger to advance the moving ram. This closes the crimp jaws to hold the terminal in place. DO NOT deform the wire barrel.
4. Insert stripped wire into wire barrel of splice until the end of the conductor is against the splice wire stop. See Figure 4.
5. Activate tool to complete the crimp.
6. To crimp the other half of the butt splice, reposition it in the crimping jaws and repeat Steps

1 through 5. If the splice cannot be turned, rotate crimping head. See Figure 4.

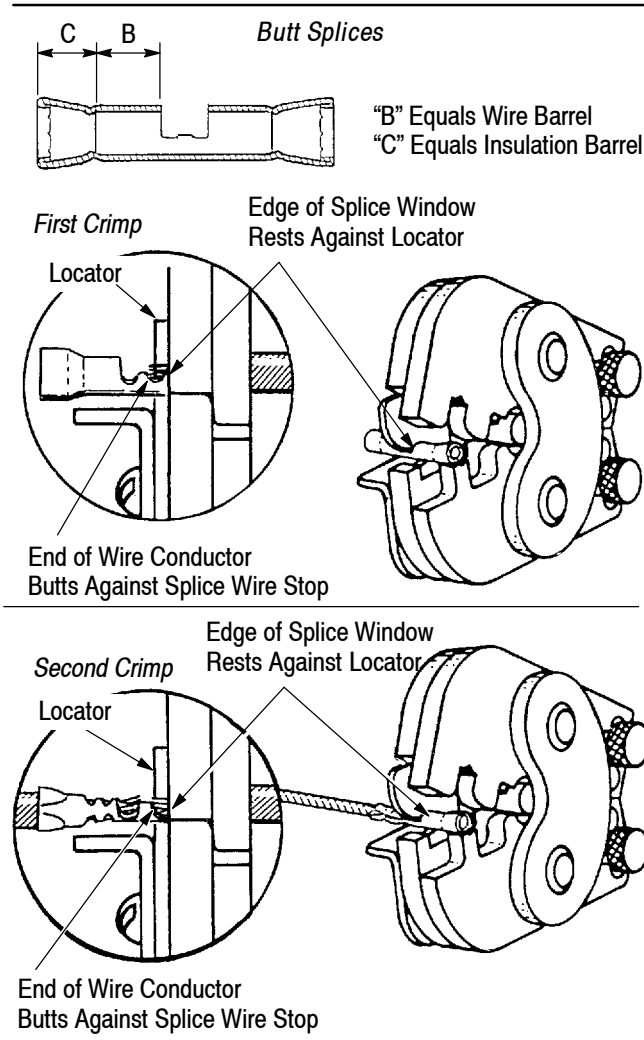

Figure 4

7. Refer to Section 5 and Figure 6 for crimp inspection.

4.3. Insulation Crimp Adjustment

The insulation crimping section of the crimping head has three positions: 1—Tight; 2—Medium; and 3—Loose.

1. Insert insulation adjustment pins in Position 3. See Figure 5.

NOTE
 Always place both adjustment pins in the same position. See Figure 5.

2. Place the terminal or splice in crimping jaws, as shown in Figure 3.

3. Insert **unstripped** wire **only** into the **insulation barrel** of the terminal or splice. See Figure 3 or Figure 4.

4. Crimp the terminal or splice as described in Paragraph 4.1 or Paragraph 4.2.

5. Remove the terminal or splice. Bend wire forward and then backward. The terminal or splice should retain its grip on the wire. If the wire pulls out, reposition the insulation adjustment pins in the next tighter position and repeat crimping procedure.

6. Repeat adjustment as necessary until desired insulation grip is obtained. **DO NOT** use a tighter setting than required.

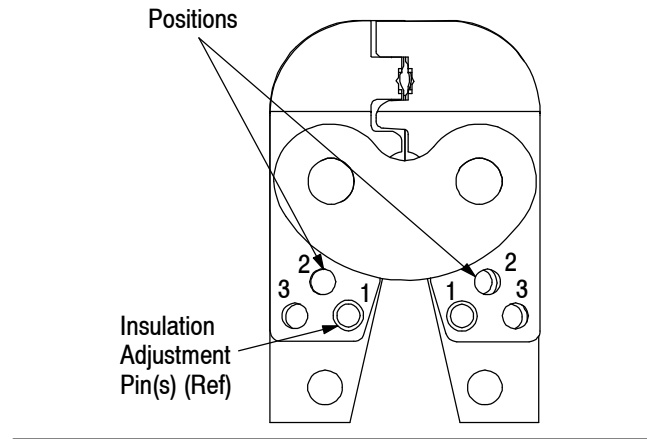

Figure 5

5. CRIMP INSPECTION

Inspect crimped terminals and splices by checking the features described in Figure 6. Use only terminals or splices that meet the conditions shown in the “ACCEPT” column. “REJECT” terminations can be avoided through careful use of instructions in Section 4, and by performing regular head maintenance, as described in Section 6.

6. MAINTENANCE AND INSPECTION

DANGER
 To avoid personal injury, ALWAYS disconnect the battery from the tool before performing maintenance or inspection.

Tyco Electronics recommends that a maintenance and inspection program be performed periodically to ensure dependable and uniform terminations. The crimping head should be inspected once a month. Frequency of inspection should be adjusted to suit your requirements through experience. Frequency of inspection depends on:

1. The care, amount of use, and handling of the crimping head.

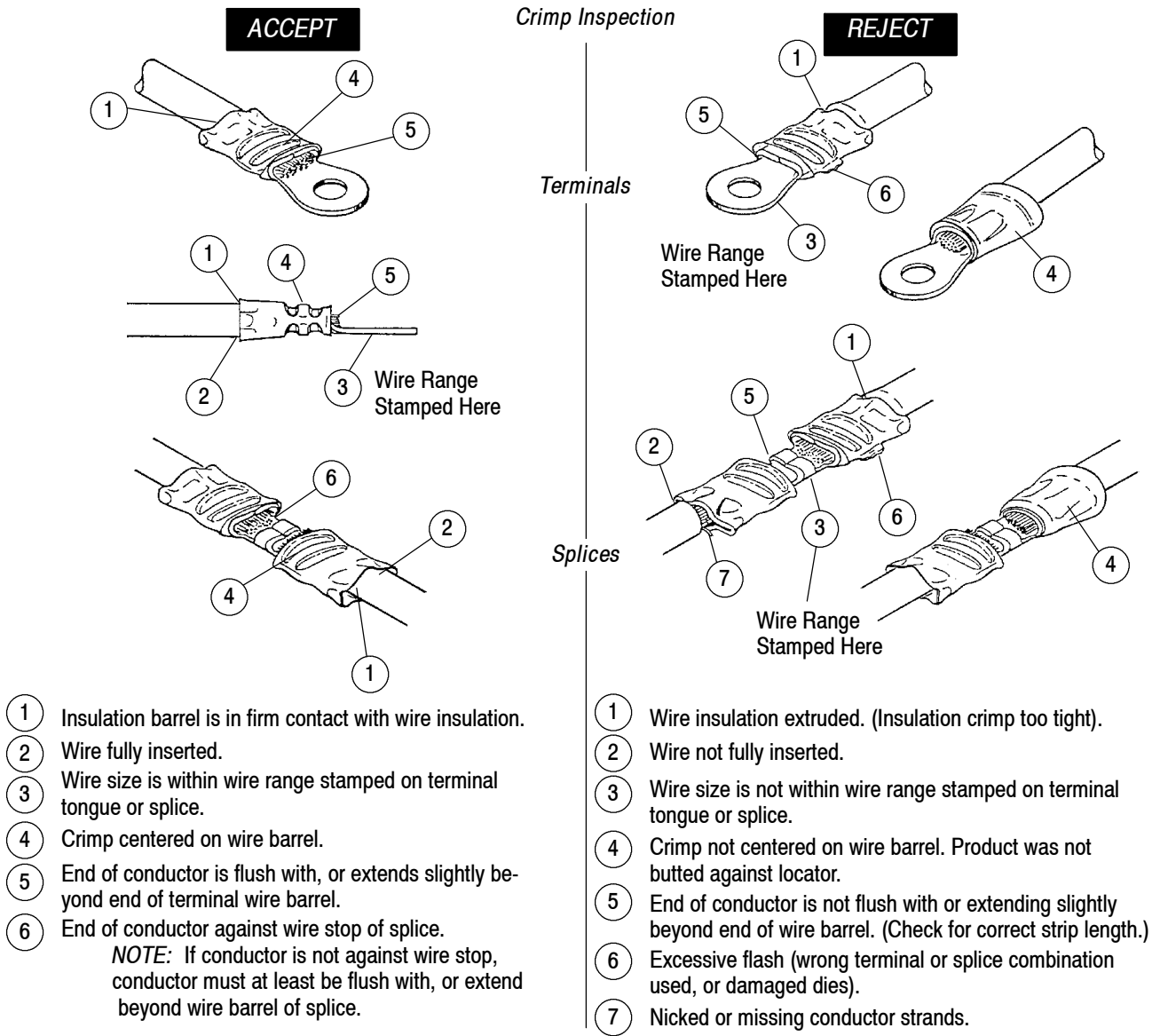

Figure 6

2. The degree of operator skill.
3. The presence of abnormal amounts of dust and dirt.
4. Your own established standards.

Each crimping head is thoroughly inspected before packaging. Since there is the possibility of crimping head damage during shipment, new crimping heads should be inspected immediately upon arrival at your facility.

6.1. Daily Maintenance

Tyco Electronics recommends that each operator be responsible for the following steps of daily maintenance:

5. The type and size of the product crimped.

1. Remove dust, moisture, and other contaminants with a clean, soft brush, or a lint-free cloth. Do NOT use objects that could damage the head.
2. Make sure that all pins, rings, and other components are in place and secure.



To avoid personal injury and damage to the tool, make sure quick pins are properly inserted.

3. Make certain all surfaces are protected with a thin coat of any good SAE 20 motor oil. Do NOT oil excessively.
4. When the head assembly is not in use, store it in a clean dry, area.

6.2. Periodic Inspection

Regular inspections should be performed by quality control personnel. A record of scheduled inspections should remain with the crimping heads or be supplied to supervisory personnel responsible for the crimping heads. Though recommendations call for at least one inspection a month, the frequency should be based on amount of use, working conditions, operator training and skill, and your established company policies. These inspections should include a visual inspection (Paragraph 6.3) and a crimping chamber inspection (Paragraph 6.5).

6.3. Visual Inspection

1. Remove all lubrication and accumulated film by immersing the crimping head in a suitable commercial degreaser that will not affect paint or plastic.
2. Make certain all components are in place. If replacements are necessary, refer to Figure 9.
3. Check all bearing surfaces for wear. Replace worn parts.
4. Inspect crimp area for flattened, chipped, or broken areas. Replace worn or damaged parts.

6.4. Lubrication

Lubricate all pins, pivot points, and bearing surfaces with a high quality grease. Tyco Electronics recommends the use of Molykote grease, which is a commercially available lubricant. Lubricate according to the following schedule:

- Head used in daily production – lubricate daily
- Head used daily (occasional) – lubricate weekly
- Head used weekly – lubricate monthly

Wipe excess grease from crimping head, particularly from jaw closure areas. Grease transferred from jaw closure area onto certain terminations may affect the electrical characteristics of an application.

6.5. Gaging the Crimping Chamber

This inspection requires the use of plug gages conforming to the dimensions shown in Figure 7. Tyco Electronics does not manufacture or market these gages.

DANGER Disconnect the battery and remove crimping head from tool before inspecting crimping chambers.



1. Remove oil and dirt from the jaw bottoming surfaces and plug gage element surfaces.
2. Close wire barrel crimping jaws until they are bottomed, but not under pressure.

Suggested Plug Gage Design - Wire Barrel Crimp

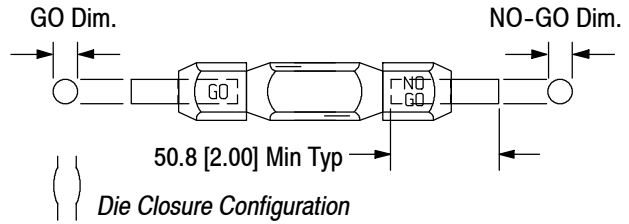

TOOL NUMBER	GAGE ELEMENT DIMENSIONS	
	GO	NO-GO
1-48070-0	1.245-1.252 [.0490-.0493]	1.394-1.397 [.0549-.0550]
1-49512-0	1.753-1.760 [.0690-.0693]	1.902-1.905 [.0749-.0750]
1-49513-0	2.032-2.040 [.0800-.0803]	2.182-2.184 [.0859-.0860]

Suggested Plug Gage Design - Insulation Crimp

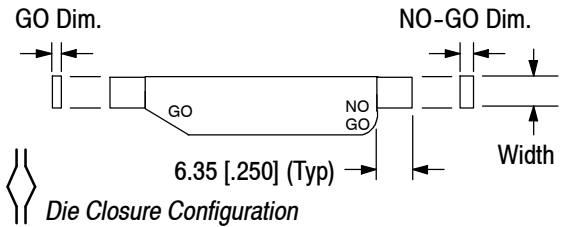

TOOL NUMBER	GAGE ELEMENT DIMENSIONS (Set Insulation Adjustment Pins in No. 1 Position)		WIDTH (MAX.)
	GO	NO-GO	
1-48070-0	0.381-0.389 [.0150-.0153]	0.886-0.889 [.0349-.0350]	2.36 [.093]
1-49512-0	0.762-0.770 [.0300-.0303]	1.267-1.270 [.0499-.0500]	3.18 [.125]
1-49513-0	0.762-0.770 [.0300-.0303]	1.267-1.270 [.0499-.0500]	3.18 [.125]

Figure 7

3. Align GO element with wire barrel crimping section. Push element straight into crimping chamber without using force. The GO element must pass completely through the chamber as shown in Figure 8A.
4. Align the NO-GO element and try to insert it into the chamber. The element may start entry, but it must not pass completely through the crimping chamber.
5. Repeat this procedure for the insulation crimping section using a plug gage as shown in Figure 8B.

If the crimping chamber passes the gage inspection, the crimping head is considered dimensionally correct and should be lubricated with a THIN coat of any good SAE 20 motor oil. If the crimping chamber does not conform to the plug gage conditions, contact your

local Tyco Electronics Field Representative or refer to Section 7, REPLACEMENT AND REPAIR.

or send a facsimile of your purchase order to 1-717-986-7605, or write to:

For additional information about the use of a plug gage, see Instruction Sheet 408-7424.

CUSTOMER SERVICE (38-35)
 TYCO ELECTRONICS CORPORATION
 P.O. BOX 3608
 HARRISBURG, PA 17105-3608

7. REPLACEMENT AND REPAIR

Replacement parts and recommended spares are listed in Figure 9. The recommended spares should be stocked for immediate replacement.

For further repair and replacement information, call the Tyco Electronics Tooling Assistance Center at the number at the bottom of page 1.

Order replacement parts through your Tyco Electronics Representative, or call 1-800-526-5142,

8. REVISION SUMMARY

- Updated document to incorporate requirements

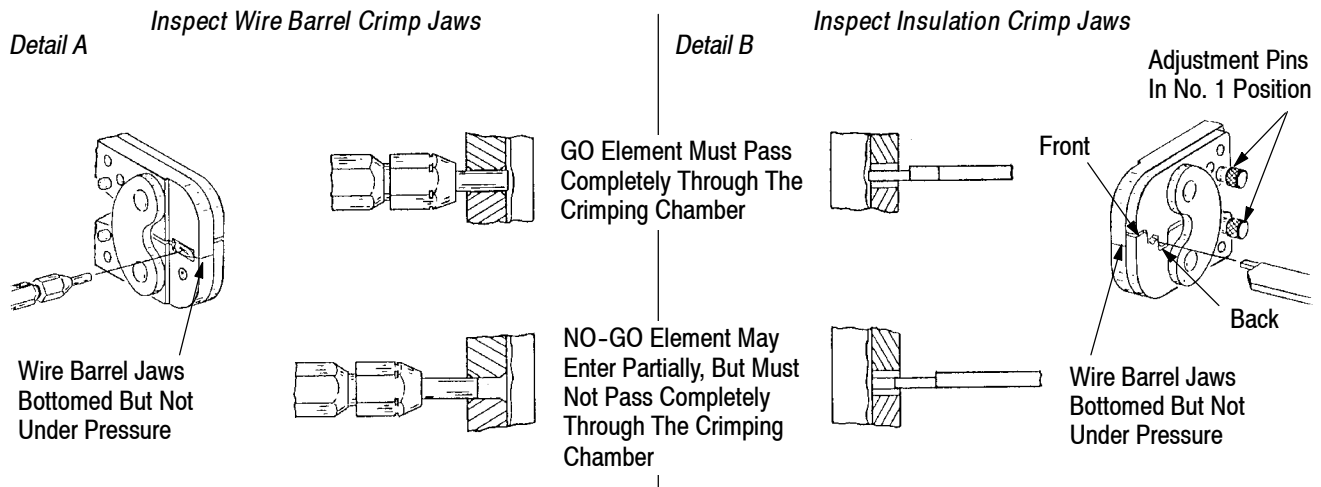
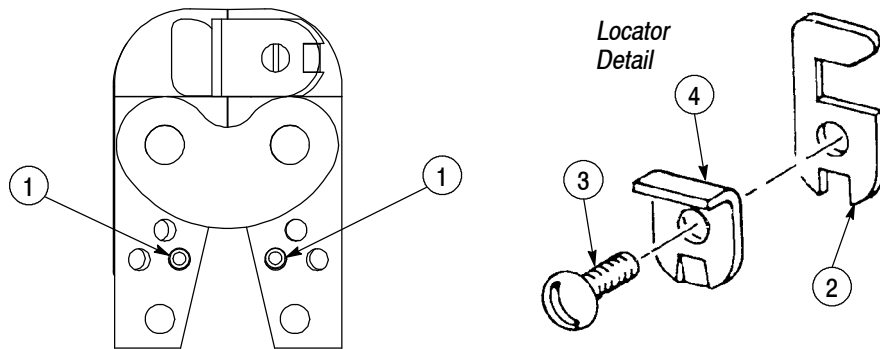

Figure 8



REPLACEMENT PARTS

ITEM NO.	DESCRIPTION	TOOL NUMBERS AND LOCATOR DETAIL REFERENCE			QTY PER HEAD
		1-48070-0	1-49512-0	1-49513-0	
1	PIN, Insulation Adjustment	39207	39207	39207	2
2	LOCATOR	39280	39230	39231	1
3	SCREW	3-21016-4	3-305927-4	3-305927-4	1
4	BRACKET	39193	39193	39193	1

Figure 9