

**Class 1**

## EV Charge Inlet Type 1 AC

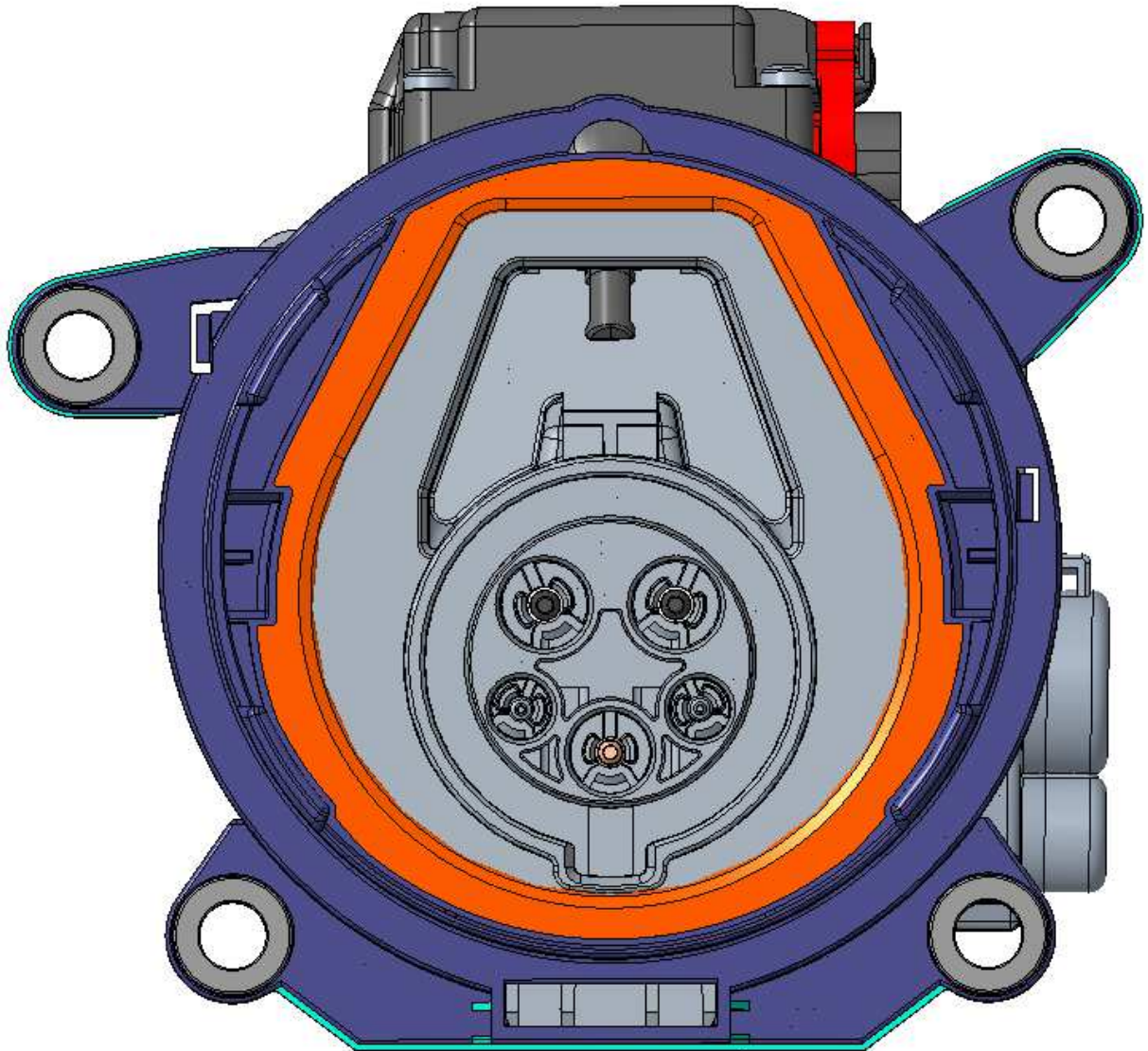

## Content

<b>1.</b>	<b>SCOPE</b> .....	<b>3</b>
1.1.	Content.....	3
1.2.	Processing Note.....	3
<b>2.</b>	<b>APPLICABLE DOCUMENTS</b> .....	<b>3</b>
2.1.	TE Connectivity Documents.....	3
2.2.	General Documentation.....	4
<b>3.</b>	<b>APPLICATION TOOLS</b> .....	<b>5</b>
<b>4.</b>	<b>Wires</b> .....	<b>6</b>
4.1.	Assessment of the wires.....	6
4.2.	Wire selection.....	6
4.3.	Wire preparation.....	6
<b>5.</b>	<b>Requirements on the crimped contact</b> .....	<b>7</b>
5.1.	Conductor position.....	7
5.2.	Crimp Geometry.....	7
5.3.	Cross Sections.....	8
5.4.	Wire pull-out forces.....	8
5.5.	Crimp Position.....	9
5.6.	Contact area.....	9
5.7.	Sealing area.....	9
5.8.	Shape and position tolerances.....	10
5.9.	Measuring equipment and measuring position.....	10
<b>6.</b>	<b>ASSEMBLY INSTRUCTIONS</b> .....	<b>11</b>
6.1.	Assembly overview Charge Inlet Type 1 AC.....	11
6.2.	Parts to order.....	12
6.3.	Assembly Configurations Cable Exit.....	13
6.4.	Security Advice.....	14
6.5.	Assembly Steps.....	15
6.6.	End of Line Test.....	26

## 1. SCOPE

### 1.1. Content

This specification describes the assembly and handling of the vehicle charge inlets Type 1 AC acc. IEC62196-2 and SAE1772 for conductive charging of electric vehicles. This specification applies to manual assembly of the components in series production configuration.

### 1.2. Processing Note

The processor is responsible for the quality of the manufacturing process to ensure the correct function of the system. The warranty and liability is excluded if quality deficiency or damages occur due to non-compliance to this specification or use of not specified or not released tools, cables and components.

## 2. APPLICABLE DOCUMENTS

The following technical documents, if referred to, are part of this specification. In case of a contradiction between this specification and the product drawing or this specification and the specified documentation, the product specification has priority.

### 2.1. TE Connectivity Documents

#### a) Customer drawings for inlet type 1 AC

INLET HSG, TYPE 1, ASSY	2298458
CABLE EXIT, RECT, 90 DEG	2296063
PERIPHERAL SEAL, 63, 63, AC	2320214
FAMILY SEAL, AC	2350592
STRAIN RELIEF, AC	2344703
COVER, CABLE SEAL, AC	2296057
MQS CAVITY PLUG	963143
PIN DIA 2,8mm, RIGID, PE	2293267
PIN DIA 3,6mm, RIGID, POWER AC, ASSY	2293266
PROTECTION CAP, TE, WATER DRAIN	2292534

#### b) Specifications / Spezifikationen

114-13000	Application Specification Micro Mate-N-Lock Connectors
108-94519	Product Spec. TE actuator for charge inlets

## 2.2. General Documentation

### Cable Specifications of Prescribed Cables

#### AC-cable: cross-section 2 x 6.0mm<sup>2</sup>

Supplier	Coficab
Outer Diameter	12.8 <sup>-0,6</sup> mm
Cable description	<i>FHLR2G2GCB2G 2x6.0mm<sup>2</sup> similar LV216-2 Tab. A.5</i>
Supplier Part No.:	2GCB2G26 H

#### PE-cable: cross-section 6.0mm<sup>2</sup>

Supplier	Coficab
Outer Diameter	4,3 <sup>-0,3</sup> mm
Cable description	<i>A3-3TBD acc. ISO 6722</i>
Supplier Part No.:	A30600 80

#### Signal-cable: cross-section 0,5mm<sup>2</sup>

Outer Diameter	1.6 <sup>-0,2</sup> mm
Cable description	<i>FLRY 0,5mm<sup>2</sup> acc. ISO6722-1</i>

### 3. APPLICATION TOOLS

To produce a correct wire crimp, as validated by TE with the wires listed in this specification, following application tools are required.

The press machine for crimping is required to provide minimum 20 tons press force.

Wire Size [mm <sup>2</sup> ]	Stripping Length single wire for crimp [mm]	Crimp height CH <sub>1</sub> [mm]	Cable Specification	Supplier	Contact P/N	Geometry	Applicator	Crimping press used by TE for Crimp Validation
6	13,0 ± 1	3,7 ± 0,1	FHLR2G2GCB2G 2x6.0mm <sup>2</sup>	Coficab	2293266-3	W	7-528041-0	Hanke 971-200. Cycle time: 1.7 - 2.5s Stroke: 44mm
			A3-3TBD	Coficab	2293267-3		7-528041-1	

Table 1

Crimp Die Sets are subject to wear and their condition and quality have to be monitored. Suspect and/or worn Die Sets have not to be used for the production of these crimps. Die Sets are available as spare parts.

---

## 4. WIRES

### 4.1. Assessment of the wires

To ensure the required electrical crimp contactability with stable crimp resistance a permissible maximum storage period of 8 months for unprocessed cable (referring to cable manufacturer production date) has to be respected.

### 4.2. Wire selection

The contact system is released for the application with wires specified in chapter 2.2  
The released contact-wire-combinations and crimp parameters are given in table 1.

Other wires require the validation and approval of the TE engineering department.  
The wires are applied as single wire terminations. Double terminations are not intended.

### 4.3. Wire preparation

The cable insulation must be stripped before crimping. The stripping length of the outer insulation and shield is defined in the following Assembly Steps.

The insulation must be cut accurately and pulled off from the conductor. Offcut of insulation must not remain on the conductor. Single strands may not be damaged, fanned out, cut or pulled out. Furthermore the operator should avoid touching the bare single strands and the strands shall not be twisted. All single strands need to be caught in the crimp and not a single strand must remain outside the crimp.

## 5. REQUIREMENTS ON THE CRIMPED CONTACT

The following terms shown below are used in this specification, see figure 1.

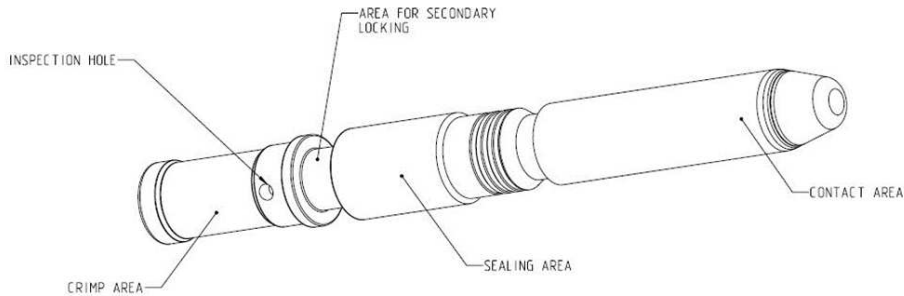

Figure 1

### 5.1. Conductor position

The single strands of the conductor are clamped inside the crimp area. All single strands need to be caught in the crimp and not a single strand must remain outside the crimp.. The wire end must be fully inserted into the crimp area and has to be checked via the inspection hole after crimping. Insulation must not be inside of the crimping area, see figure 2

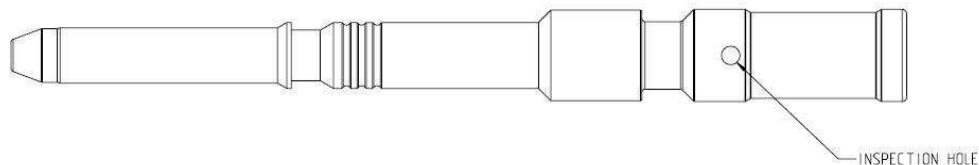

Figure 2

### 5.2. Crimp Geometry

The crimp geometry, crimp heights including their corresponding tolerances as well as wire sizes are given in table 1.

The crimp height is the key quality feature of a crimp connection. The measurement allows a non-destructing examination and a continuous process inspection. It is provided for every wire size and contact. The crimp height is given in table 2.

Crimp height and width may also be measured in a cross section image. The mechanical operated measurement though is preferred.

During the application process the crimp height must be checked. This is valid for each batch and after every change or switchover of contact reel or wire bundle or applicator respective it's setup or components.

The crimp height has to be measured over both extensions in middle of the crimp, figure 3:



Figure 3 (pic exemplarily)

### 5.3. Cross Sections

When creating cross sections, the correct grinding layer must be selected. The Grinding layer had to be at middle of crimp area and may not be inside of serration, see figure 4.

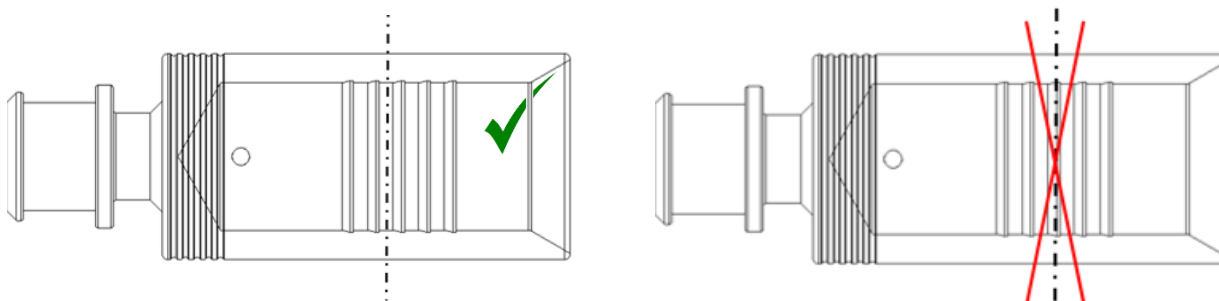

Figure 4 (pic exemplarily)

### 5.4. Wire pull-out forces

Measurement of wire pull-out forces from the wire crimp is a supporting manufacturing control.

The pull-out forces must fulfil the requirements according product specification 108-xxxxx



### 5.5. Crimp Position

The TE applicator positions the contacts in the crimping tool at middle position as shown, figure 5 and 6. Correct position and condition of applicator has to be checked for every production lot.

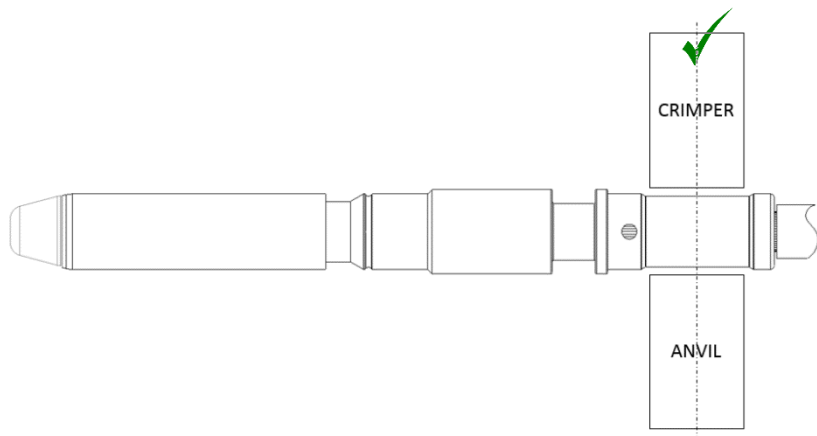

Figure 5 (pic exemplarily)

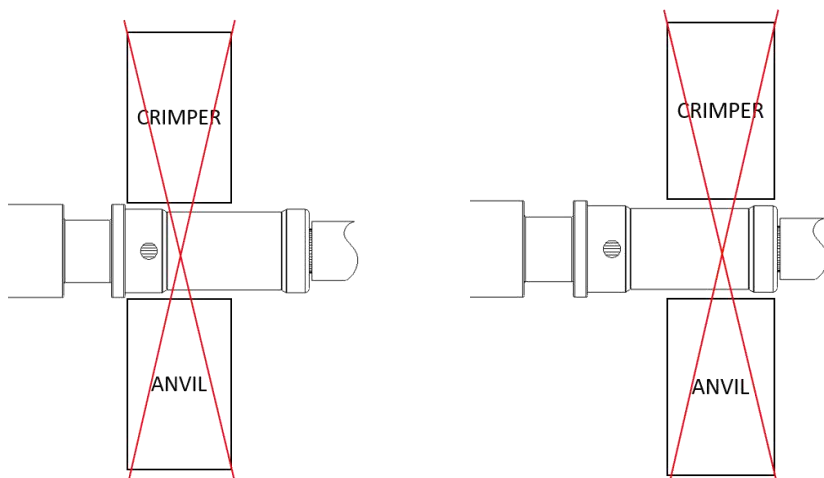

Figure 6 (pic exemplarily)

### 5.6. Contact area

During processing and following processing the contact area may not be damaged or bended.

### 5.7. Sealing area

During processing and following processing the sealing area may not be damaged or bended

## 5.8. Shape and position tolerances

Measuring the shape and position deviation is not always necessary, if the contact is obviously straight by eye. In case a measurement is required, the measurement equipment required at least a 10-time better measuring precision compared with the requirement tolerances, see figure 7 and 8.

Meeting the specific shape and position tolerances must be ensured before the contact is inserted into the housing.

If contacts are bent during the application process and exceed the specified tolerances these must not be bent back or reworked but have to be scrapped.

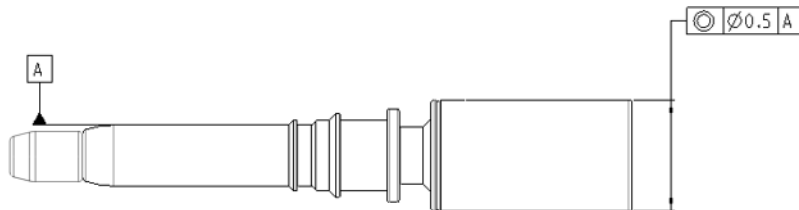

Figure 7 (pic exemplarily)

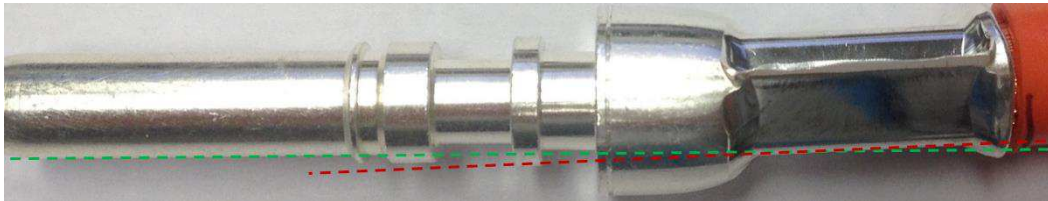

Figure 8 (pic exemplarily)

## 5.9. Measuring equipment and measuring position

As measuring equipment for measuring crimp height, a digital caliper with accuracy of measuring 0.01mm is the minimum requirement. Measuring of crimp height had to be done according as following always in middle of crimp area across whole crimp, see figure 9 and figure 3.



Figure 9 (pic exemplarily)

## 6. ASSEMBLY INSTRUCTIONS

### 6.1. Assembly overview Charge Inlet Type 1 AC

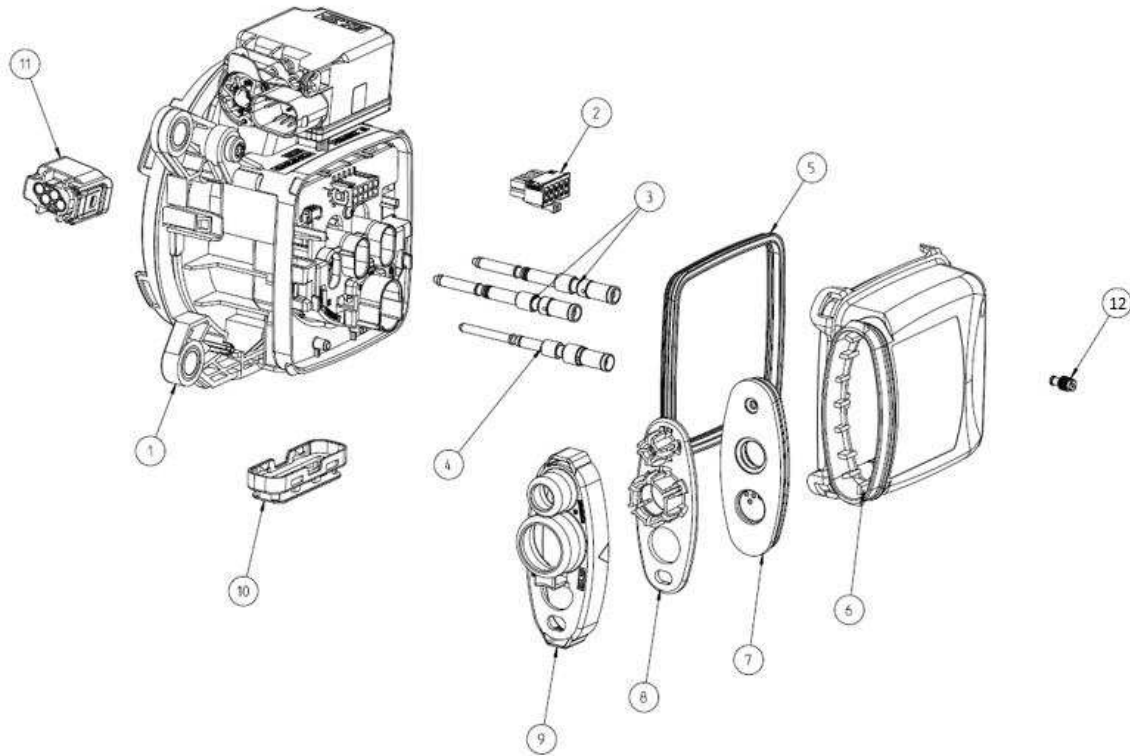

Figure 10

## 6.2. Parts to order

<b>Charge inlet Type 1 AC</b>			<b>1-phase AC 6mm<sup>2</sup></b>
<b>Part</b>		<b>Variant</b>	
<b>Pos.</b>	<b>Qty.</b>	<b>Name / Bezeichnung</b>	<b>P/N</b>
1	1	INLET HSG, TYP 1, ASSY	2298458-1
2	1	10P MICRO MNL ASSY, VRT, SMT, LF	Additional part for charge inlet cabling: 1-794617-0
	4	CONTACT MICRO MATE'N'LOCK	Additional part for charge inlet cabling: 0-794606-1
3	2	PIN DIA 3.6, RIGID, POWER AC, ASSY	2293266-3
4	1	PIN DIA 2.8, RIDIG, PE	2293267-3
5	1	PERIPHERAL SEAL, 63, 63 ,AC	0-2320214-1
6	1	CABLE EXIT, RECT, 90DEG	1-2296063-2
7	1	FAMILY SEAL, AC	2350592-9
8	1	STRAIN RELIEF, AC	1-2344703-4
9	1	COVER, CABLE SEAL, AC	2296057-3
10	1	PROTECTION CAP, TE, WATER DRAIN	2292534-1
11	-	4POS MQS Connector HSG, Seals and Contacts	Additional part for Actuator cabling: p/n acc. Prod. Spec. 108-94519
12	1	MQS Cavity Plug	963143-1

Table 2

### 6.3. Assembly Configurations Cable Exit

The inlet can be assembled with different cable exit directions. The required configuration can be chosen to customer request. The configurations shown in figure 11 can be realized

In this specification the version with cable exit downwards and ground cable left is shown exemplarily.

#### **Configurations for cable exit downwards:**

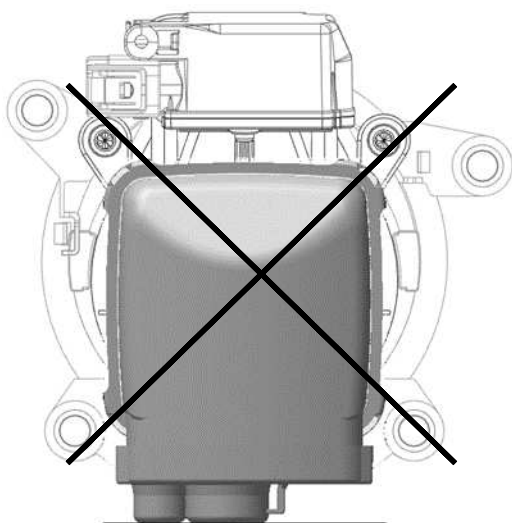

Ground cable left

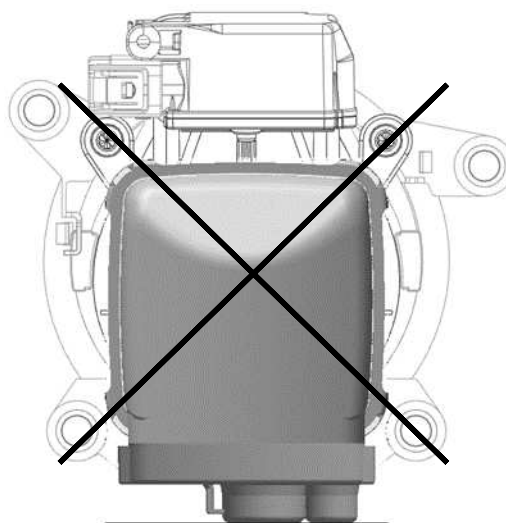

Ground cable right

#### **Configurations for cable exit sideways:**

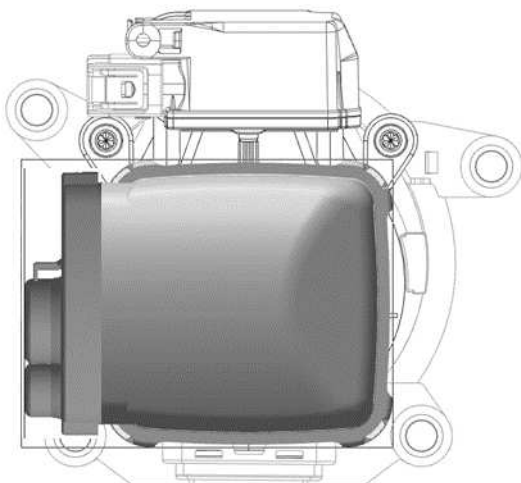

To left side with ground cable on bottom

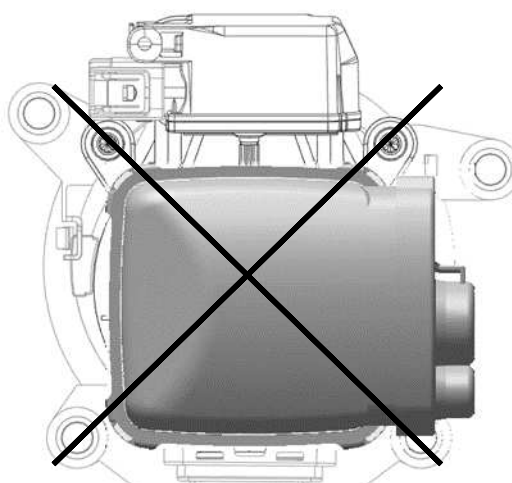

To right side with ground cable on bottom

Figure 11

## 6.4. Security Advice

**ATTENTION!**  
**- HIGH VOLTAGE APPLICATION -**  
**CABLE INSULATION MUST NOT BE DAMAGED!**



**The assembly has only be performed by trained personnel.**

**Avoid prolonged or repeated skin contact with silver plated contacts (wear protective gloves)!**

## 6.5. Assembly Steps

### Step 1

The COVER CABLE SEAL AC 2296057-3, STRAIN RELIEF AC 1-2344703-4 and FAMILY SEAL AC 2350592-9 must be pushed over the signal wires, the ground wire and the AC-Multicore wire. Pay attention to place all wires at correct positions, figure 12. Especially ensure the correct position of the flange of the L-shaped FAMILY SEAL AC towards the STRAIN RELIEF, figure 12a

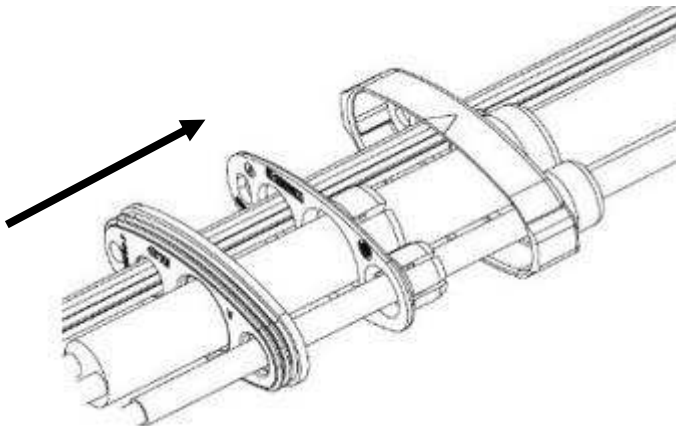

Figure 12

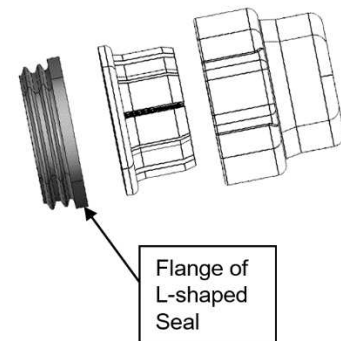

Figure 12a

### Step 2

Dismantle the wires:

#### AC-Multicore Cable

Remove outer insulation, shield and filler of AC-multicore-cable acc. figure 13 and table 3.

The given length of the single wires ensures that the outer sheath of the multicore cable seals off to the FAMILY SEAL AC 2350592. Alternatively, a marking on the outer sheath in a certain distance to the cut off position can be used to ensure the proper position of the outer sheath in the FAMILY SEAL AC.

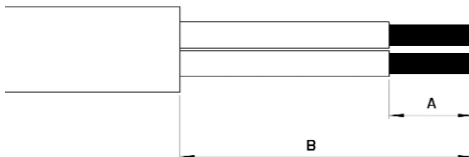

Figure 13

Wire Size	Removal of insulation dim. "A"	Length of single wires "B"
6 mm <sup>2</sup>	13 mm +/- 1mm	53 +/-2 mm for sideward cable exit direction 49 +/-2 mm for downward cable exit direction (See figure 11 for cable exit directions)

Table 3

**PE (ground) single wire**

Remove outer insulation acc. Figure 14 and table 4.

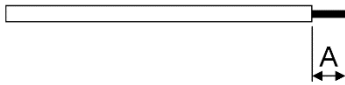

**Figure 14**

Wire Size	Removal of insulation dim. "A"
6 mm <sup>2</sup>	13 mm +/- 1mm

Table 4



**Crimp the conductors to the PIN DIA3.6 RIGID CONTACTS 2293266 and PIN DIA 2.8 RIGID CONTACT 2293267 with the specified tools listed in table 1. The crimp has to fulfill the requirements acc. Chapter 5.**

**Signal-Wires 0,5mm<sup>2</sup>**

Dismantle single wires acc. spec. 114-13000 and crimp the contacts 0-794606-1 acc. spec. 114-13000, see figure 15.

**After Crimping the subassembly of cables with cable exit components is in the condition shown in figure 16:**

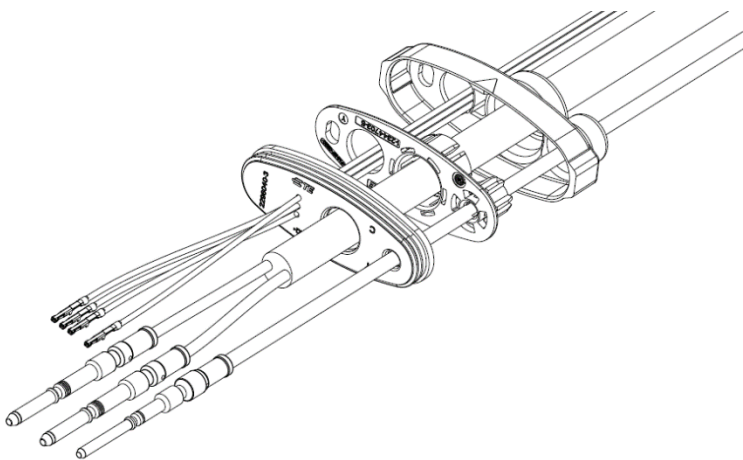

Figure 16 (schematic; crimp geometry not shown)



### Step 3

Push signal terminals 0-794606-1 (Micro Mate'n'Lock) into the Connector Housing 1-794617-0 acc. application spec 114-13000.

Pinning according figure 17:

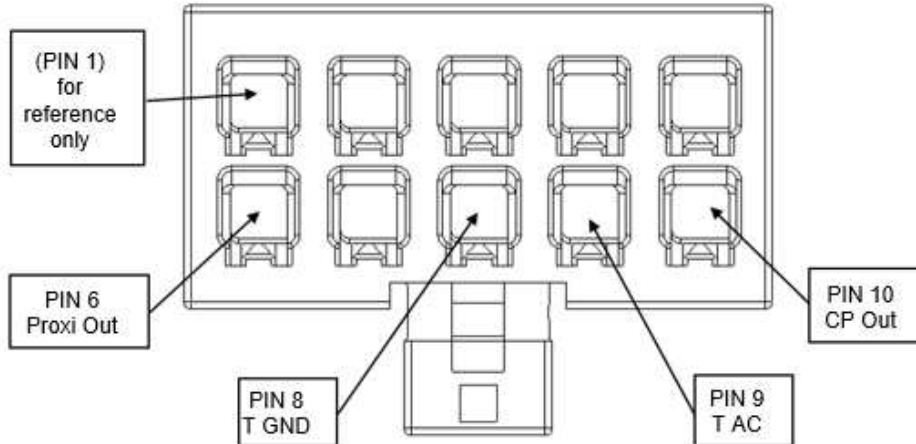

Figure 17

After Micro Mate'n'Lock connector housing assembly the subassembly of cables with cable exit components is complete, see figure 18:

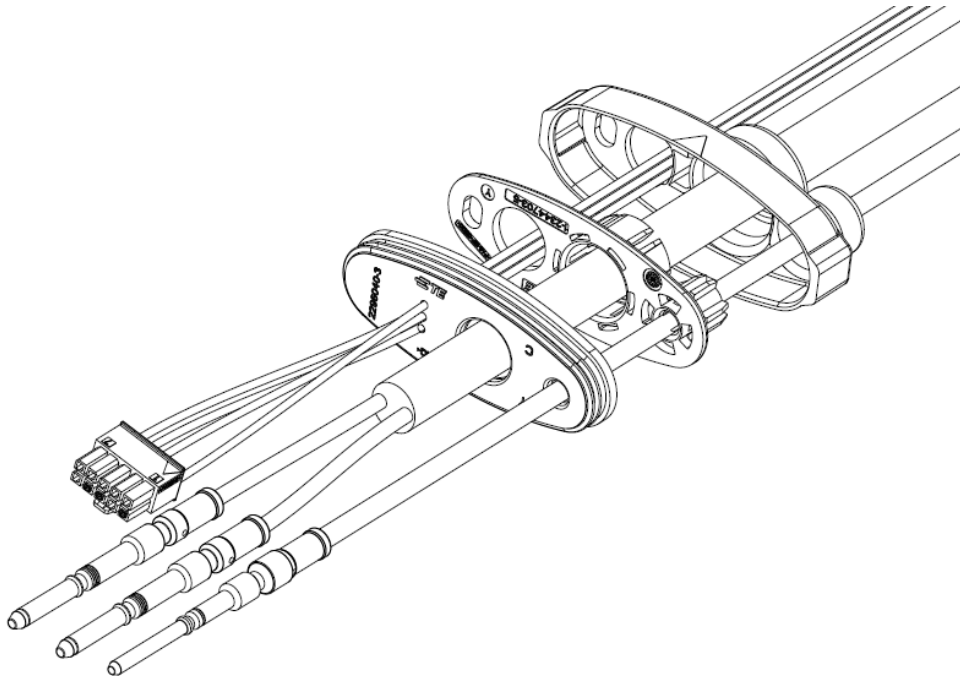

Figure 18 (schematic; crimp geometry not shown)

### Step 4



Assemble the Peripheral Seal 0-2320214-1 to the Cable Exit Cover 1-2296063-1. The Peripheral Seal has to be properly seated into the Collar of the Cable Exit Cover. The seal has a L-shaped design, pay attention to correct orientation of seal acc. Figure 19, 19a ! Wrong assembled seal will jeopardize water tightness.

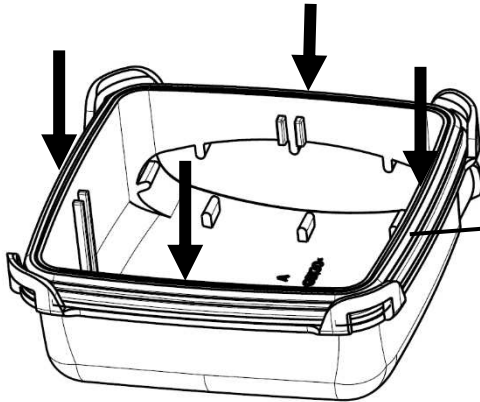

Figure 19

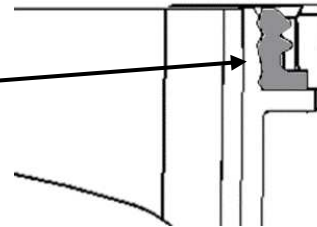

Figure 19a

### Step 5

Pass the cable subassembly (figure 17) through the AC slot in Cable Exit 1-2296063-2 (figure 20).

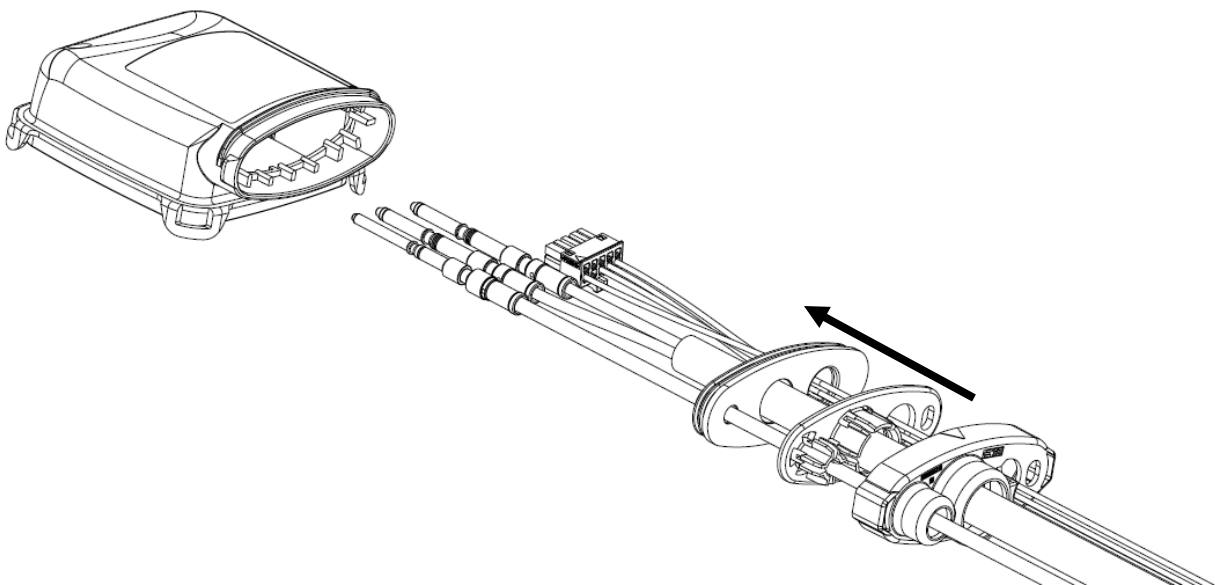

Figure 20

### Step 6

Insert the Contacts from the backside into the Inlet Housing according to the cavity description (see figure 21) into their locking position, see figure 22. To ensure that the contacts are correctly inserted, pull with a low force on the cables (max. 10N). Figure 22a shows contacts assembled in end position.

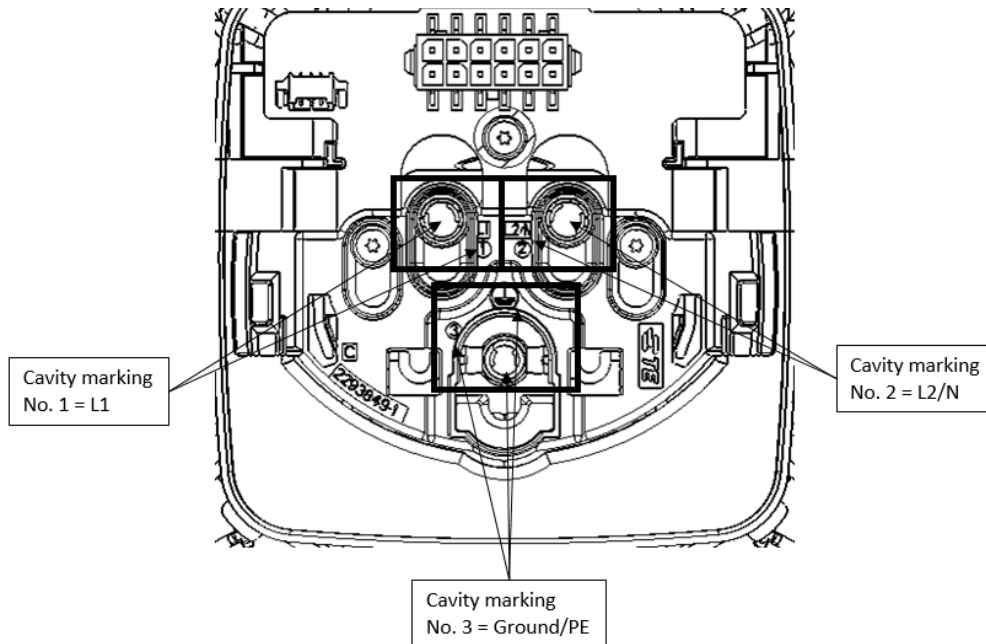

Figure 21



**ATTENTION:** The correct contact positions have to be ensured BEFORE pushing the contacts into locking their cavities in locking position. In case of wrong positioning of the contacts the complete assembly has to be scrapped. There is no rework allowed (risk of damaging contacts and/or locking geometry in housing) !

Figure 22

Figure 22a

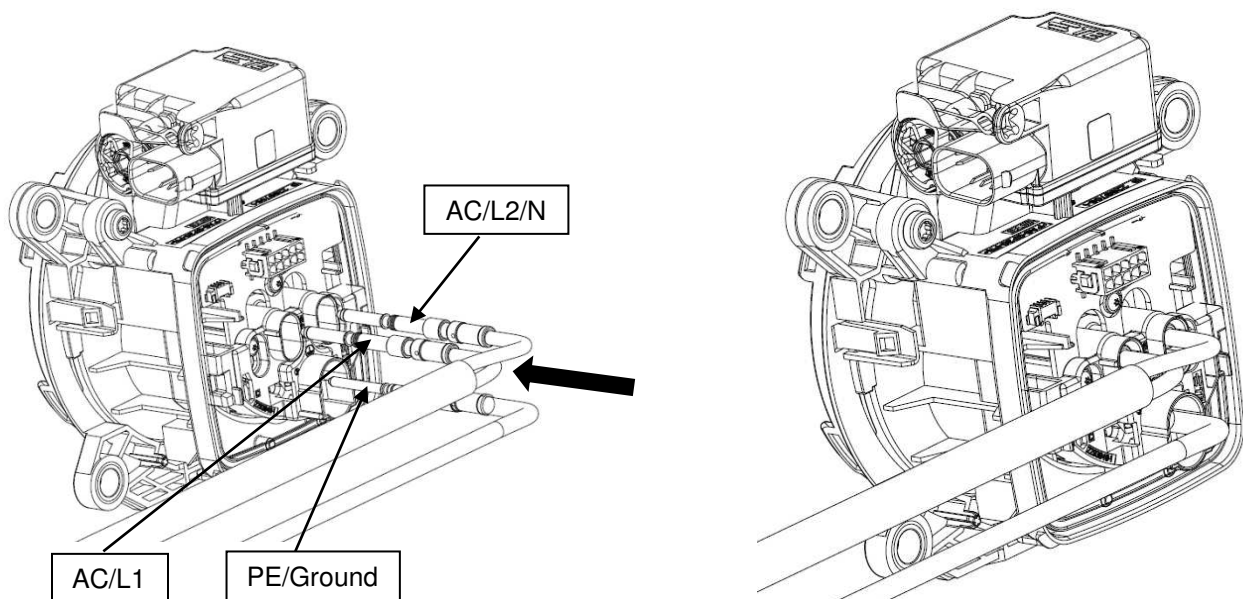

**Step 7**

After the contacts have been controlled for correct positioning and locking, the SECONDARY LOCK has to be pushed upwards (Figure 23). Ensure that both latches are properly engaged with the inlet housing, which has to be controlled by the double audible click and by visible inspection. (Figure 24 and 24a).

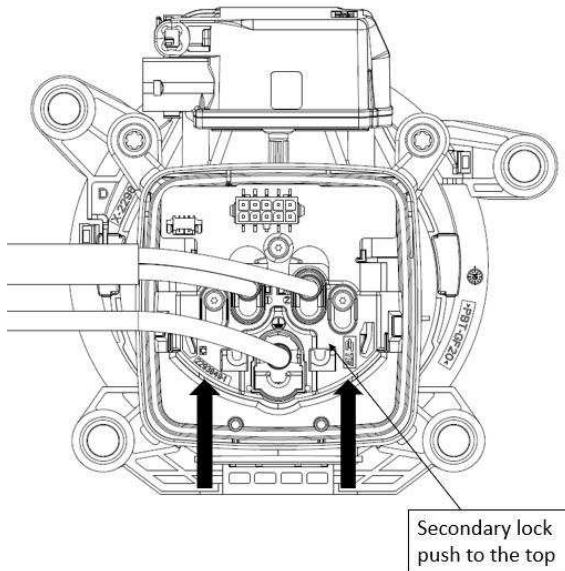

Figure 23

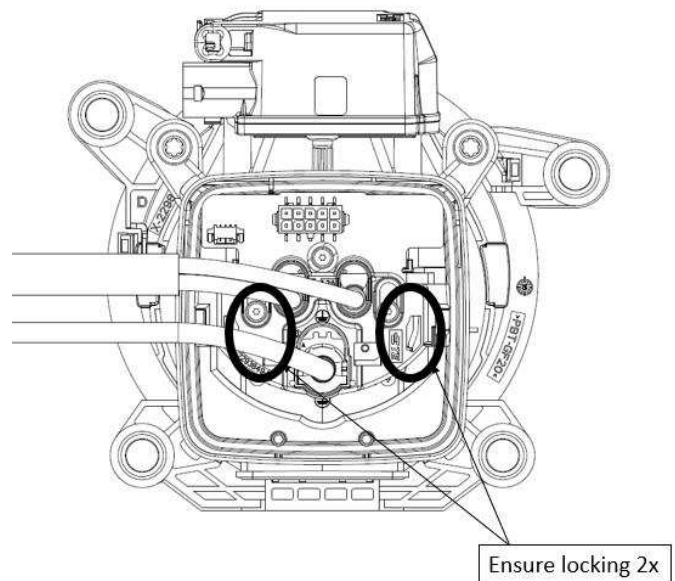

Figure 24

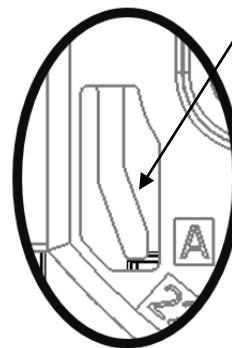

Figure 24a

**Step 8**

Connect Micro Mate'N'Lock Connector to PCB-Header. Ensure the hook is properly engaged with the header, see figure 25.

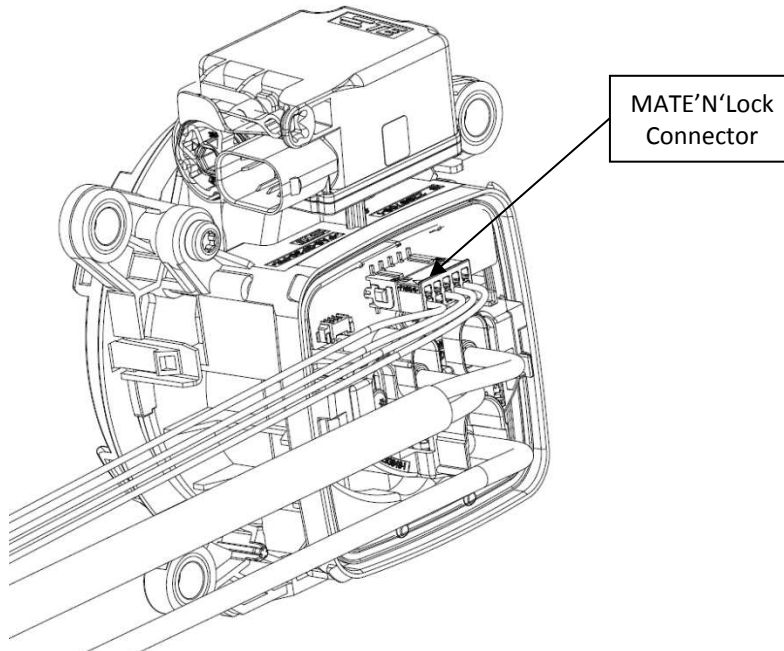

Figure 25

**Step 9**

Assemble the Cable Exit Cover 1-2296063-2 with preassembled Peripheral Seal 0-2320214-1 to the Inlet Housing Assy 2298458-1. Ensure that all 4 hooks are correctly engaged. (Figure 26). The press force has to be applied on the marked locations on the surrounding cable exit collar close to the latches, not over the complete surface of the cover, see figure 27.

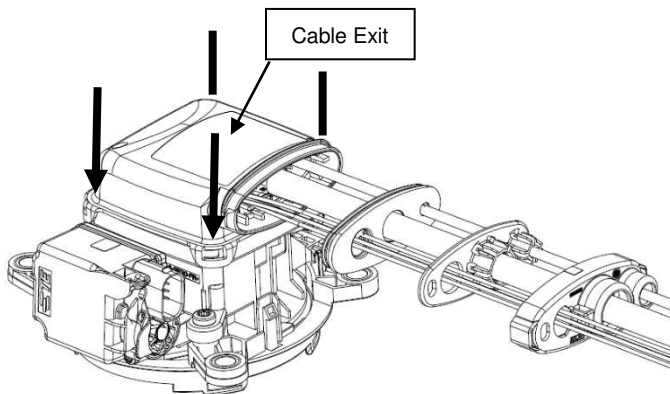

Figure 26

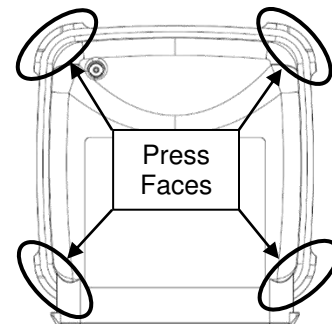

Figure 27



**Step 10**

Move the STRAIN RELIEF AC 1-2344703-4 together with FAMILY SEAL AC 2350592-9 into their position in the CABLE EXIT 1-2296063-2, see figure 28.



**ATTENTION:** Ensure that the AC-Multicore cable is well positioned in the FAMILY SEAL, that all seal lips are safely placed on the outer isolation of the cables. (Figure 29)

Push the COVER CABLE SEAL AC 2296057-3 over it and snap it on the CABLE EXIT COVER 1-2296063-2. Ensure that both hooks are correctly engaged (double audible click).

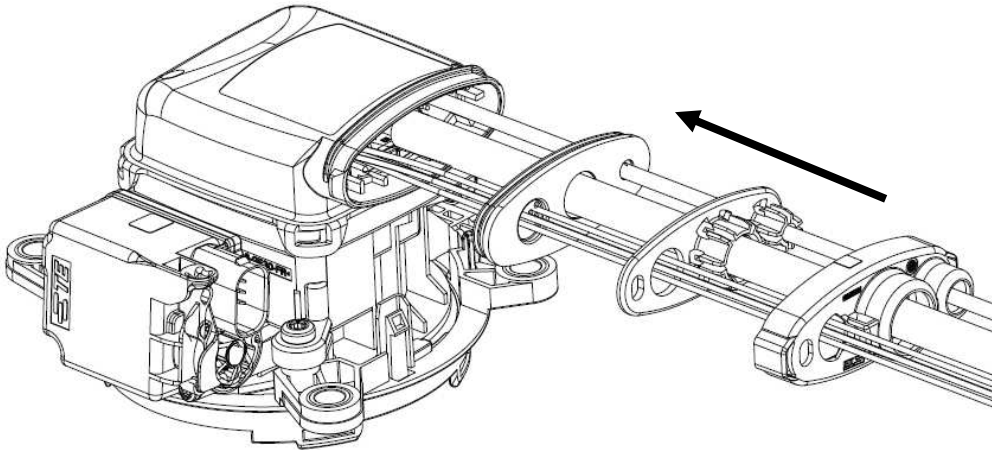

Figure 28

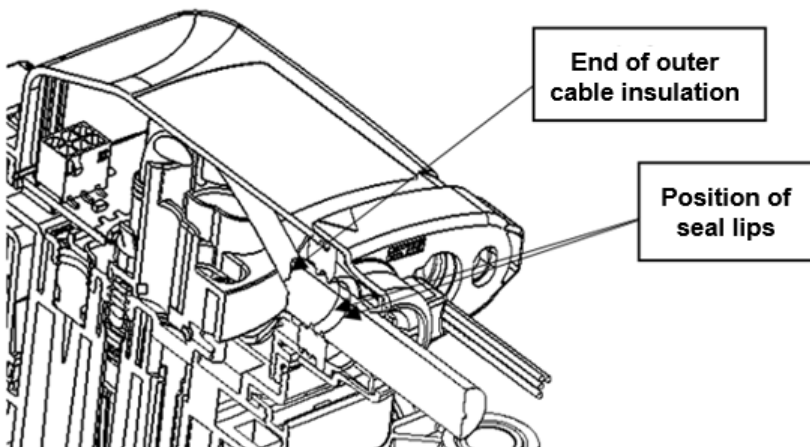

Figure 29

**Step 11**

Place a cable tie (proposed dimensions 2,5mm wide, material to be heat stabilized and suitable for automotive use) around the single wire signal cables and the bridge at the Cover Cable Seal 1-2296057-3 and pull tight, see figure 30.

**Step 12**

Assemble Protection Cap 2292534-1 at Inlet Housing, see figure 30.

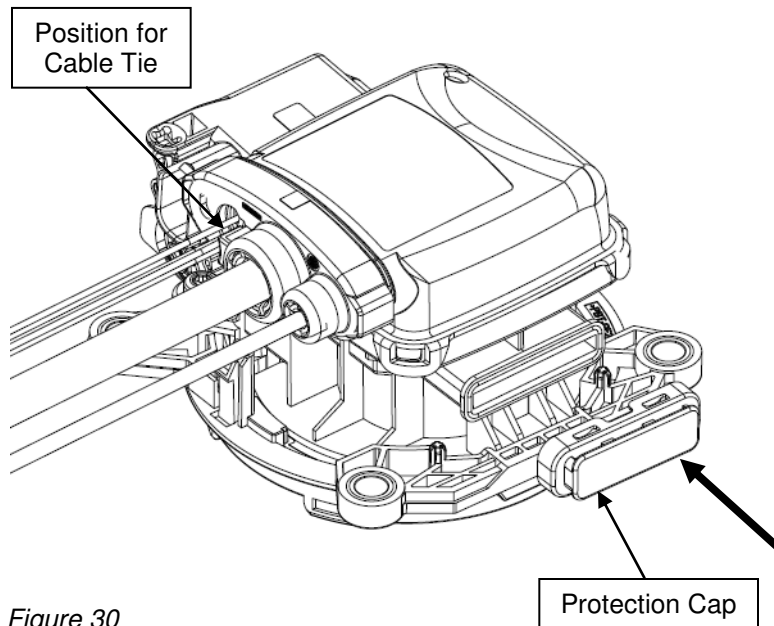

Figure 30

## Step 14

As part of the End of Line Test as listed in Chapter 6.6), perform the tightness check of the fully assembled charge inlet. The pressure port on the rear of CABLE EXIT COVER 1-2296063-2 (shown in figure 32) is designed to fit an elastic plastic tube (Polyurethan or similar) with an outer diameter of 4mm.

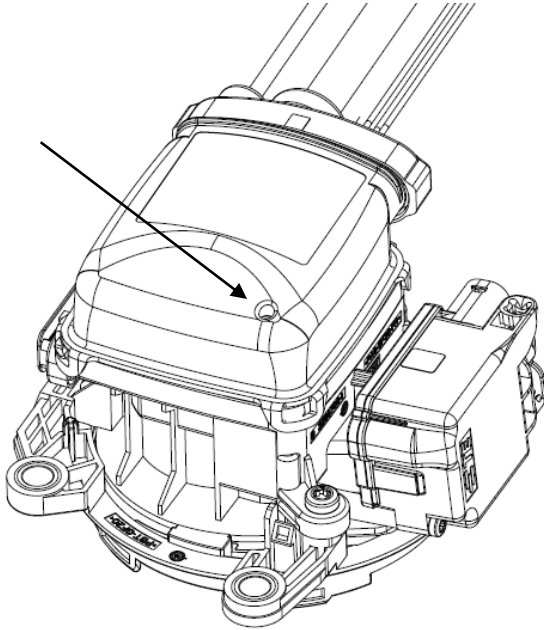

Figure 32

The tubular geometry of the pressure port has a reduced inner diameter towards the bottom to increase the pressure on the elastic tube when being inserted. The tube needs to be pushed that far into the pressure port that a sufficient air tightness can be achieved, see figure 33 for exemplarily inserted tube.

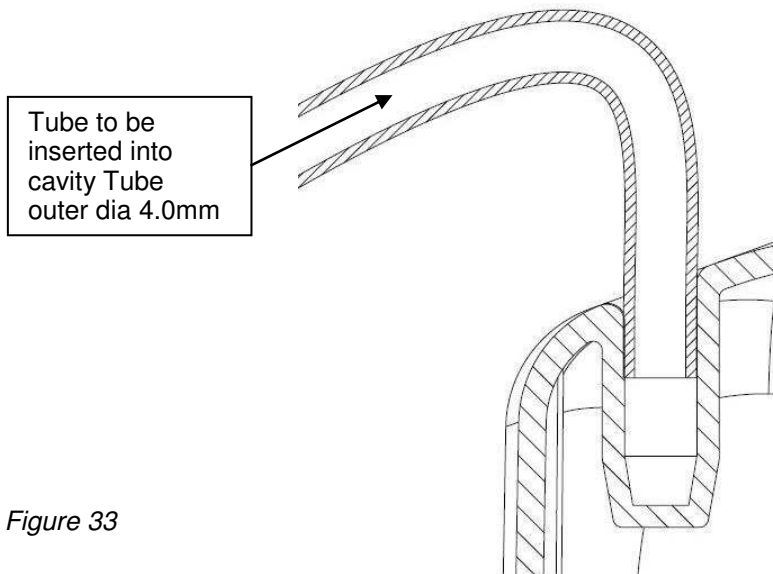

Figure 33

For the tightness check it is intended to perform an air differential pressure decay leak measurement test. Pressure profile is 0,1...0,15 bar, preferably under pressure. Acceptance criterion is pressure loss over time and has to be defined based on particularly prepared failure test samples



After successfully passed tightness check the pressure port needs to be closed with the MQS CAVITY PLUG 963143-1.

The MQS CAVITY PLUG needs to be FULLY inserted into the pressure port, see figure 34. The bottom of the pressure port is closed with a cross geometry to avoid that the MQS Cavity Plug could be pushed through.

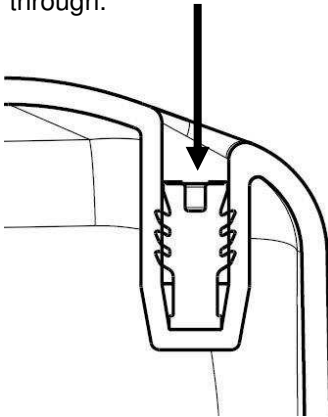

Figure 34

**Step 15**

For identification a label can be applied on this specified polished face on the CABLE EXIT, see figure 35. The label needs to include information acc. requirements of IEC 62196-1/-2 and IEC 61851 and SAE 1772. Information acc. to customer requirements can be applied here.

Marking acc. SAE J1772 / IEC62196-2:

Manufacturer Company's identification	XXXXX
Product designation or catalog or product number	Art.: XXXXXXXX
Rated Current, Voltage and Frequency	Max. 32A, 250V~ 50-60Hz / 200A, 650V
Number of Phases	1L / N / ⊕
Degree of protection	IP55 closed, IP67

There may apply additional national marking requirements, depending on the market/country the car will be configured for. Also information acc. to customer requirements can be applied here. As a compatible label TE p/n 5-1768421-9 is recommended.

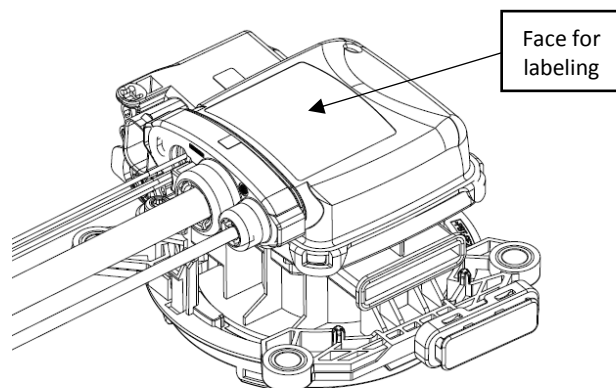

Figure 35

## 6.6. End of Line Test



The assembled Charge Inlet has to be tested electrically and mechanically to applicable requirements, including High Voltage test.

As a minimum, following tests have to be performed:

- Isolation Resistance:  
Test Voltage: 500VDC  
Inspection Duration: 1s  
min. Riso: 200M $\Omega$ m  
pin-to-pin, excluding CP-to-Proxy and CP-to-Ground and Proxy-to-Ground
  - a) L1 versus N
  - b) L1+N versus Ground
  - c) L1+N versus AC multicore shield
  - d) L1+N versus CP
  - e) L1+N versus Proxy
  
- Dielectric withstand voltage:  
Test Voltage: 2000VAC  
Inspection Duration: 1s  
max. Leakage current: 10mA  
pin-to-pin, excluding CP-to-Proxy and CP-to-Ground and Proxy-to-Ground
  - a) L1 versus N
  - b) L1+N versus Ground
  - c) L1+N versus AC multicore shield
  - d) L1+N versus CP
  - e) L1+N versus Proxy
  
- Correct Pinning of all Contacts
  
- Check seals for correct seating by Tightness Check of completed Charge Inlet Harness Assy (Air pressure test)
  
- Check correct assembled MQS Cavity Plug in the pressure port after Tightness Check.
  
- Gauge check of geometrical interface acc. IEC62196-2 / SAE1772.
  
- Functionality check of actuator. Drive (first) in lock and (second) in unlock position. During this operation, the actuator pull ring becomes pulled back in end position.

LTR	REVISION RECORD	DWN	APP	DATE
A	INITIAL DOCUMENT	S. KUMAR	S. BEAU	11MAY21

DRW S. KUMAR	TE CONNECTIVITY GERMANY GMBH AMPÈRESTRASSE 12-14 D-64625 BENSHEIM GERMANY		
CHK M. MAENCHE			
APP S. BEAU	NO 114-94719	REV A	LOC AI
TITLE	<p style="text-align: center;"><b>Application Specification</b>  <b>Vehicle Charge Inlet Type 1 AC acc. IEC62196-2</b></p>		