

**24P Mini Fuse and Relay Box**

# 24P Mini Fuse and Relay Box

- GENERAL PARTS, NOT RESTRICTED -



A	INITIAL RELEASE	20MAY2020	TEJUS KIRAN	DAVID KLEIN
LTR	Revision Record	Date	DWN	APVD

---

TABLE OF CONTENTS

1.	General.....	3
1.1	Purpose .....	3
1.2	Customer Drawings .....	3
1.3	Product Specification .....	3
1.4	Note .....	3
2.	Product Description .....	4
2.1	MOUNTING CLIPS.....	4
2.1.1	DT CLIPS.....	4
2.1.2	AMP SEAL 16 CLIPS.....	4
3.	24P Minifuse and relay box .....	5
3.1	Terminal Insertion.....	5
3.2	Mini Fuse Insertion .....	6
3.2.1	Mini Fuse Insertion – Active.....	6
3.2.2	Mini Fuse Insertion – Spare.....	7
3.3	Mini Fuse Removal.....	7
3.4	Cover Mounting.....	8
3.5	Cover Un-Mounting.....	9
3.6	Terminal Extraction.....	10
3.7	Fuse Box Mounting.....	12
3.8	Fuse Box Clips Mounting.....	12
3.8.1	Sheet metal clips mounting.....	12
3.8.2	Plastic clips mounting .....	14
3.9	Little Fuse Box Clips Mounting .....	17

**1. GENERAL**

**1.1 Purpose**

This specification describes the guidelines which must be followed during:

- a) Assembly of receptacle terminal into the housing assembly.
- b) Extraction of receptacle terminal from housing assembly with proper extraction tool.
- c) Mounting and Un-mounting of cover.
- d) Mounting and Un-mounting of fuse and relay housing assembly.
- e) Assembly and disassembly of Fuse and relay.
- f) Applicable relays.

**1.2 Customer Drawings**

This application specification is based on the latest valid customer drawing as per below table.

Item No.	Part No.	Description
1	2318967-1 & -2	24P Mini Fuse and Relay Housing Assembly
2	2318957-1 & -2	Cover, 24P Mini Fuse and Relay Housing Assembly
3	1355036	AMP MCP 2.8 Flat Type Receptacle (Group Drawing)

Table 1

Part Description	Part No	Applicable Terminal Part No	Terminal Description	Applicable Wire Size	Applicable wire seal	Terminal Application spec.
24P Mini Fuse and Relay Housing Assembly	2318967-1	1-968882-1; -3 1-1719506-1; -3	AMP MCP 2.8 Flat Type Receptacle	0.35 mm <sup>2</sup> to 3 mm <sup>2</sup>	828904-1, 828905-1	114-18148
24P Mini Fuse and Relay Housing Assembly	2318967-2	1-968882-1; -3 1-1719506-1; -3	AMP MCP 2.8 Flat Type Receptacle	0.35 mm <sup>2</sup> to 3 mm <sup>2</sup>	828904-1, 828905-1	114-18148

Table 2

**1.3 Product Specification**

This application specification is valid for the products specified in the product specification 108-94651. The product specification contains information about technical details and performances. For this product, the temperature rating: -40°C to +125°C.

**1.4 Note**

Some of the named components within this specification are not scope of supply. These components include fuses, fuse puller, relay & sheet metal bracket used for mounting. The harness maker can separately order fuses, fuse puller, relay and should manufacture the sheet metal mounting bracket based on the bracket dimensions.

All work on terminals must be accomplished considering the appropriate processing specifications of the respective terminals.

If terminals are to be replaced, it is necessary that neither the contacts nor the cavity are damaged during this process. Use TE recommended extraction tool wherever specified. Defective parts must be replaced.

All parts must be processed at ambient temperature.

The harness or the cable itself must be affixed to protect the assembly and contacts against additional force.

**2. PRODUCT DESCRIPTION**

24P Mini Fuse box consists of a sealed housing which can be assembled with AMP MCP 2.8 sealed contacts.

The sealed housing can hold 12 Active fuses or 6 Active Fuses + 2 Active Relays as per requirement.

It is coupled with a top cover which seals the fuses and relays to avoid water ingress inside the housing. This cover can hold up to 4 spare fuses.

Snap mounting arrangement has been provided on the housing to ensure that the fuse box remains intact in its position during vehicle operation.

For 2318967-1, the mounting arrangement is provided which can be used with DT and AMP Seal 16 mounting clips.

For 2318967-2, the mounting arrangement is provided which can be used with Little fuse Bracket.

**2.1 MOUNTING CLIPS**

**2.1.1 DT CLIPS**

Part Number	Material	Description
1027-003-1200	Stainless steel	Metal clip, 11mm Hole Mounting bracket DT/DTM/DTP/DTHD
1027-004-1200	Zn Plated Steel	Metal clip, 13mm Hole Mounting bracket DT/DTM/DTP/DTHD
1027-005-1200	Stainless Steel	Metal clip, 13mm Hole Mounting bracket DT/DTM/DTP/DTHD
1027-008-1200	Zn Plated steel	Metal Clip, 11mm Hole Side Mounting Bracket DT/DTM/DTP/DTHD
1027-009-1200	Zn Plated steel	Metal Clip, 13mm Hole Side Mounting Bracket DT/DTM/DTP/DTHD
1027-017-1200	Zn Plated steel	Metal Clip, 8.2mm Hole Side Mounting Bracket DT/DTM/DTP/DTHD
1011-026-0205	PA6/6 GF13-15	Attachment Clip DT Series
1011-030-0205	Nylon 6/6	Attachment Clip 'T-Stud' mount, DT Series
1011-310-0205	Nylon 6/6	Attachment Clip, Fir Tree Stud Mount DT & DTM Series

**2.1.2 AMP SEAL 16 CLIPS**

Part Number	Material	Description
1924487-1	Nylon 6/6	Retainer Clip, Ampseal 16
1924487-2	Nylon 6/6	Retainer Clip, Ampseal 16, With Anti Rotational Post
1924487-3	Nylon 6/6	Retainer Clip, Ampseal 16, Small Tree with Bowl and Rails

Note: Refer mounting clip customer drawings for recommended thread types and panel thickness.  
Not validating 1924487-1 and -3

**3. 24P MINIFUSE AND RELAY BOX**

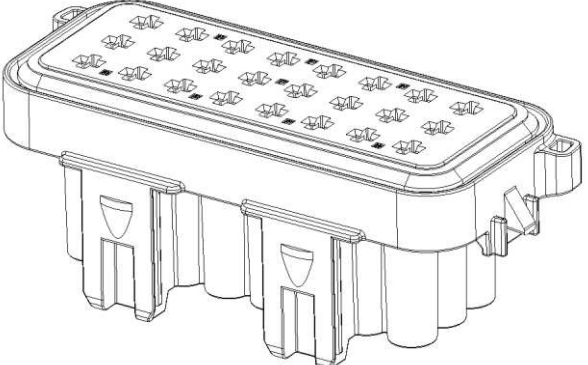
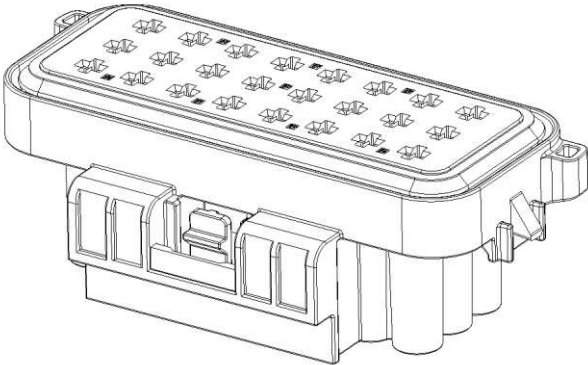
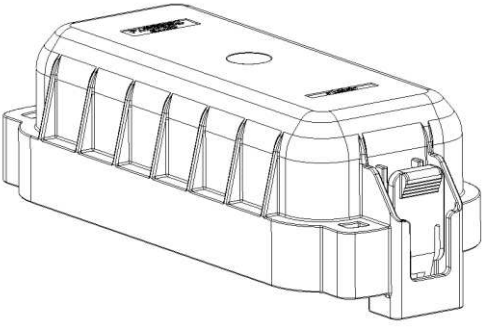
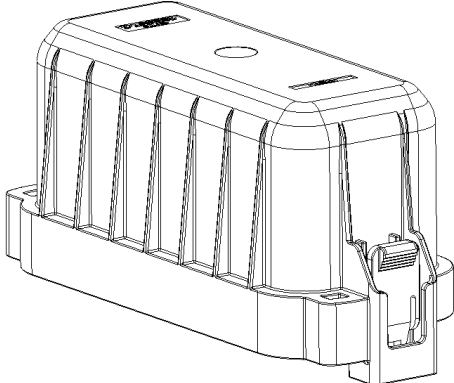
	
<p>Figure 1 2318967-1 24P Mini Fuse and Relay Housing Assembly</p>	<p>Figure 2 2318967-2 24P Mini Fuse and Relay Housing Assembly</p>
	
<p>Figure 3 2318957-1 Cover, 24P Mini Fuse Housing Assembly</p>	<p>Figure 4 2318957-2 Cover, 24P Mini Fuse and Relay Housing Assembly</p>

**3.1 Terminal Insertion**

AMP MCP 2.8 Flat Type Receptacle (TE P/N as mentioned in Table 2)

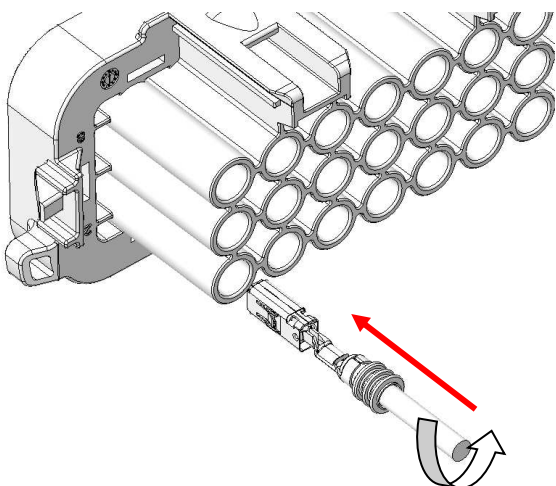

Orient the terminal as shown in figure 3 and insert it in the housing cavity. The terminal locks with a click sound.

Contact Orientation 180° Turnable

Figure 5

### 3.2 Mini Fuse Insertion

#### 3.2.1 Mini Fuse Insertion – Active

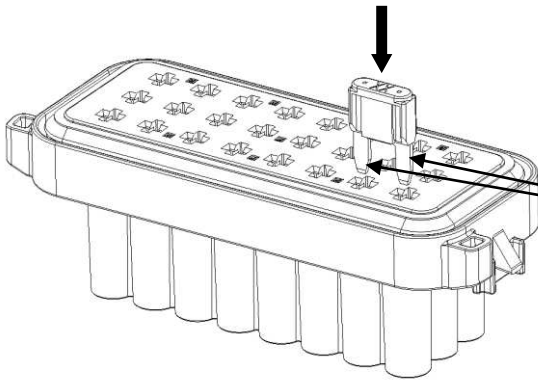

Orient the Fuse as shown in Figure 7 and push the Fuse in the shown direction.

Figure 7

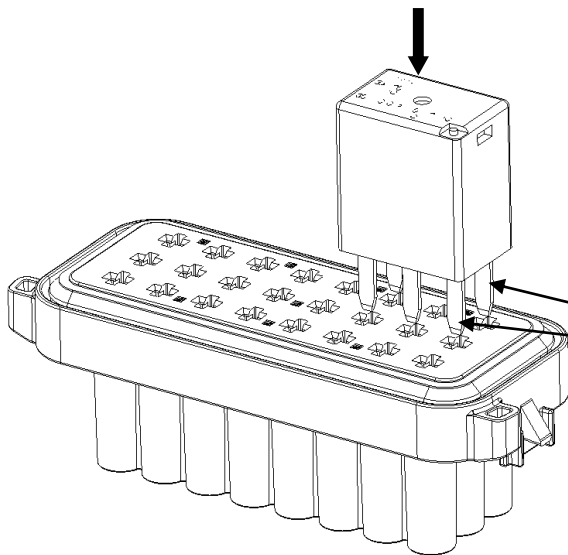

Orient the Relay as shown in Figure 8 and push the Relay in the shown direction.

Figure 8

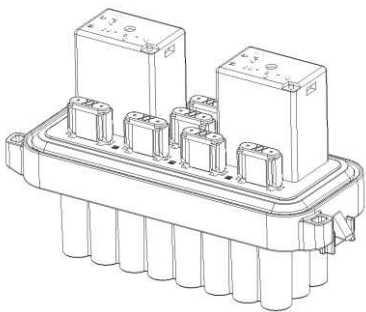

Figure 9

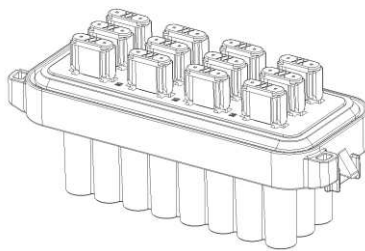
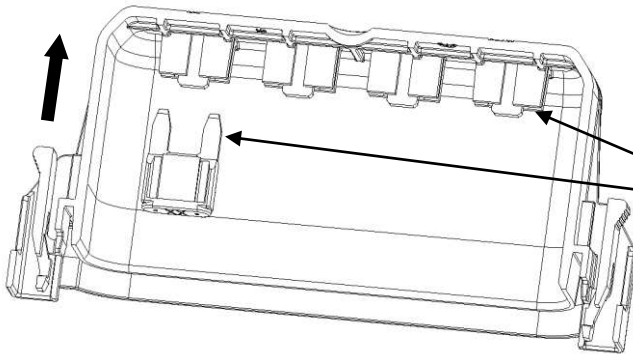

Figure 10

After inserting both active fuses and relays, final assembly will look as shown in Figure 9 and 10.

### 3.2.2 Mini Fuse Insertion – Spare



Orient the Fuse as shown in Figure 11 and push the fuse up to the end position as shown in Figure 12  
Cover holds the Spare fuses.

Figure 11

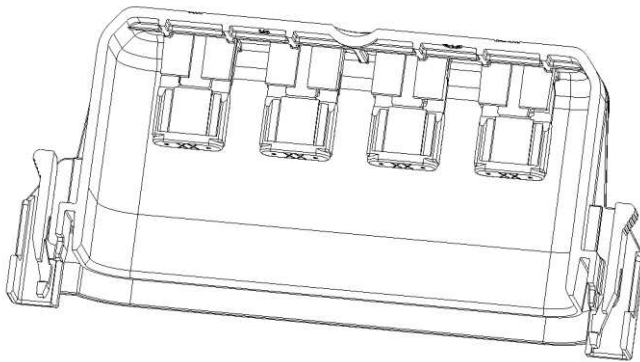

After inserting Spare fuses, final assembly will look as shown in Figure 12.

Note: Fuses to be purchased separately by the customer.

Figure 12

### 3.3 Mini Fuse Removal

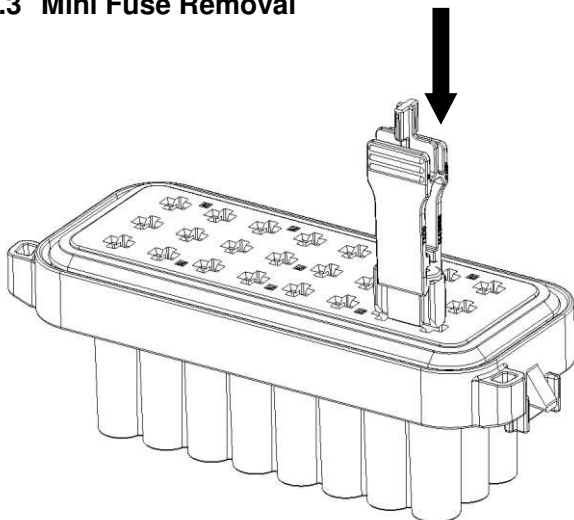

For replacement of faulty fuses, it is recommended to use a fuse puller. To replace a fuse, insert the fuse puller on the fuse as shown in Figure 13.

Note: Fuse puller is not a part of fuse box kit. Fuse puller part number: 1443998-1

Figure 13

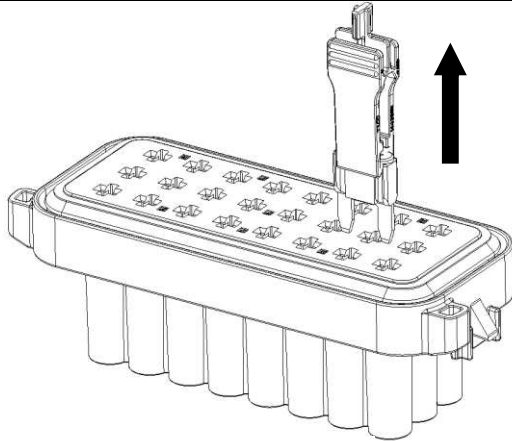

Figure 14

Pull the fuse puller in the upward direction to disengage the fuse from the terminals as shown in Figure 14. Replace the faulty fuse with a new one from the spare fuses.

### 3.4 Cover Mounting

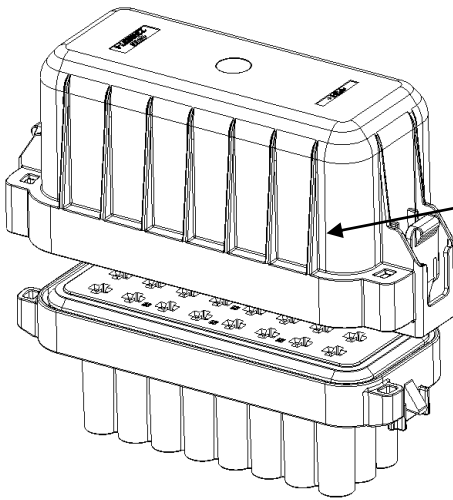

Figure 15

Poka-Yoke designed on cover will not allow the insertion of the cover in reverse direction. See Figure 15.

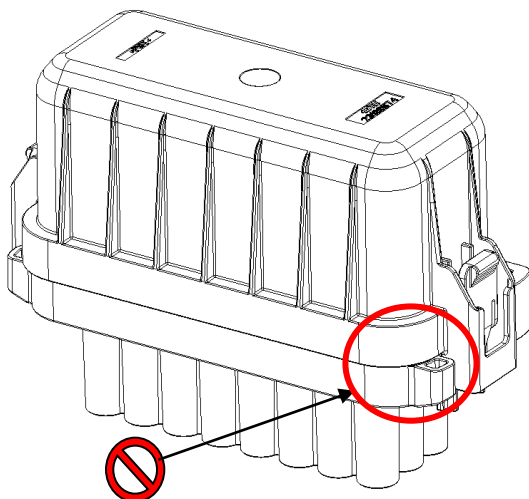

Figure 16

Figure 16 shows wrong orientation of cover during assembly.



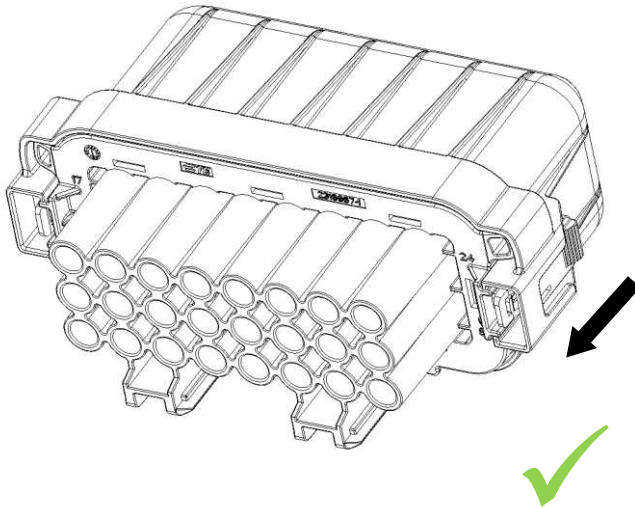

Figure 17

Figure 17 shows correct orientation of cover during assembly. In this orientation, push the cover up to end position until the Cover locks with a click sound.

\*Ensure both snaps are locked. See Fig. 18.

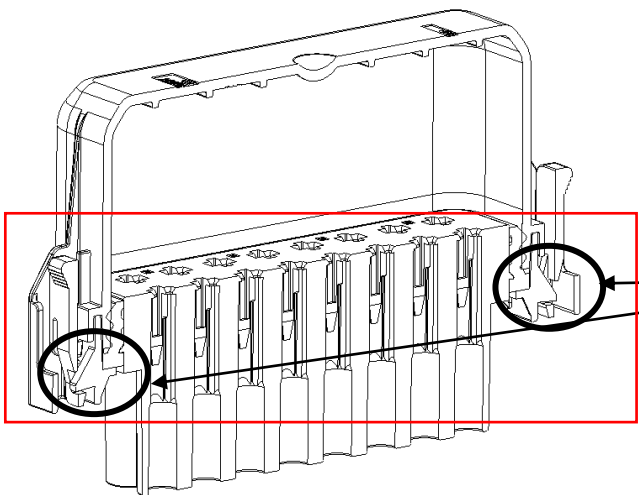

Figure 18

Cover Locking with Fuse Box housing. Both snaps are locked.

### 3.5 Cover Un-Mounting

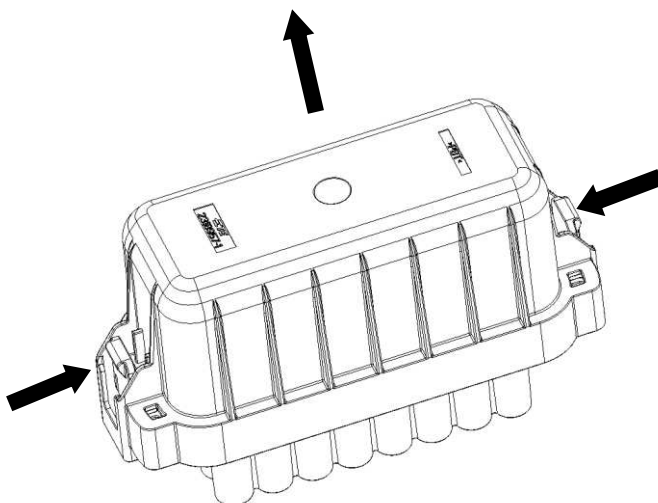

Figure 19

Press both the cover snap locks simultaneously as shown in figure 19 and pull the cover in the upward direction to release it completely.

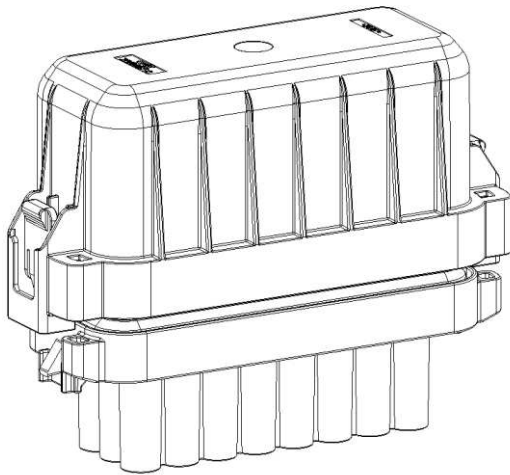

Figure 20 shows cover released completely.

Figure 20

### 3.6 Terminal Extraction

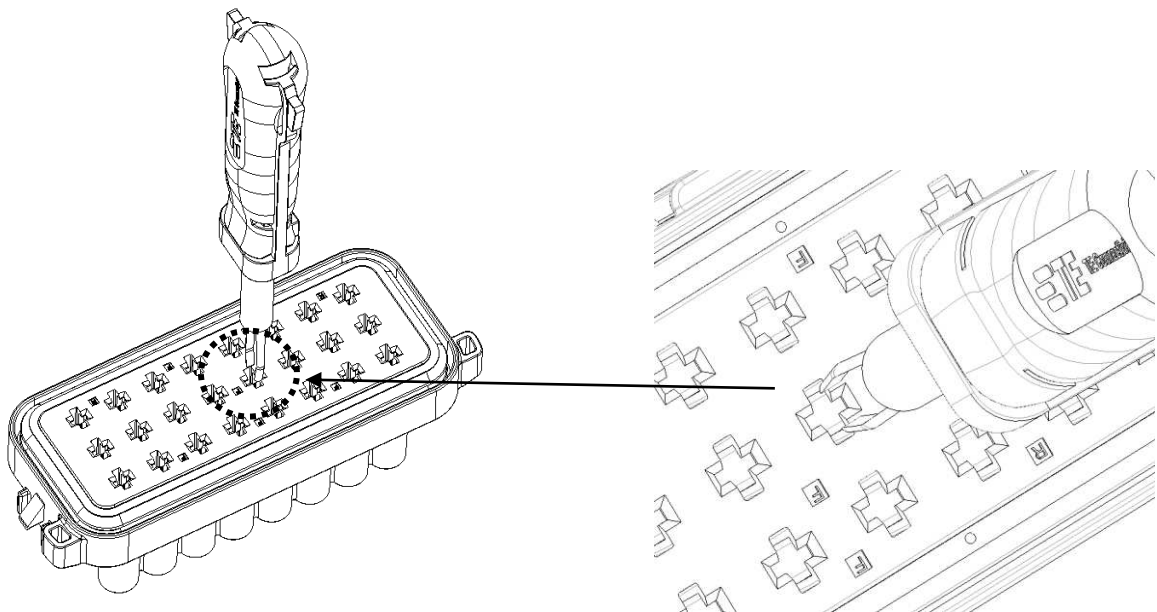

Figure 21

For replacement of fuse box contacts, it is highly recommended to use extraction tool P/N: 1579007-1 to avoid damage to terminal or the housing cavity. Insert the extraction tool in the housing cavity as shown in figure 21. Below figures show sectional view of the extraction tool & housing cavity indicating removal process.

Figure 22 – Extraction tool entering the terminal cavity.

Figure 23 – Extraction tool fully engaged and terminal latch closed for removal.

Figure 24 – Pull the contact in the downward direction. It releases from the housing cavity as seen in figure.

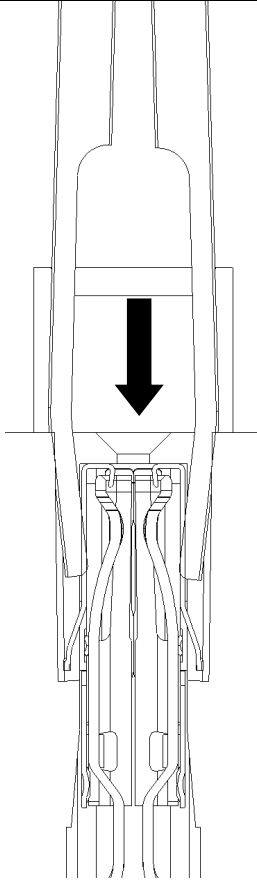

Figure 22

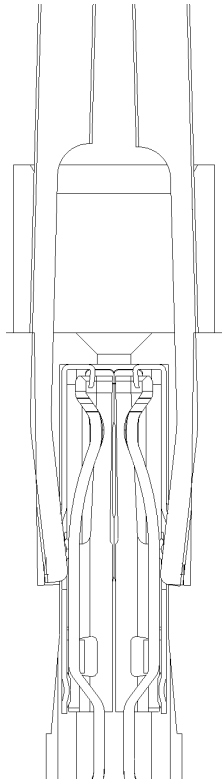

Figure 23

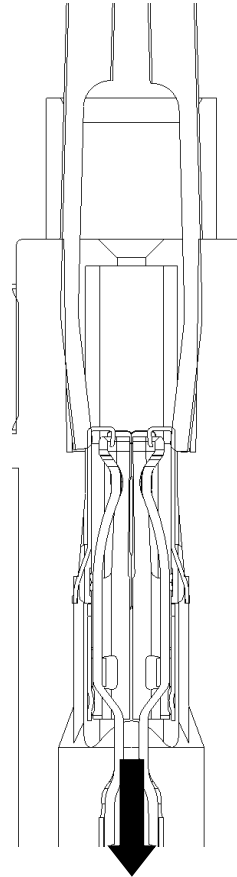

Figure 24

### 3.7 Fuse Box Mounting

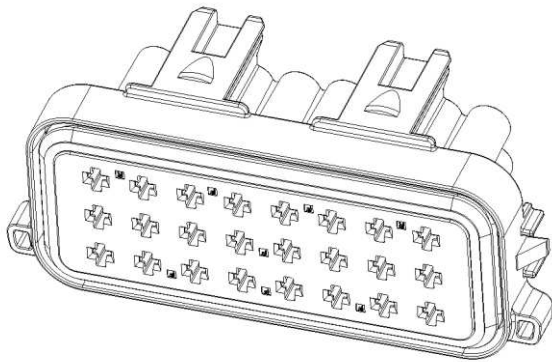

Figure 25  
2318967-1

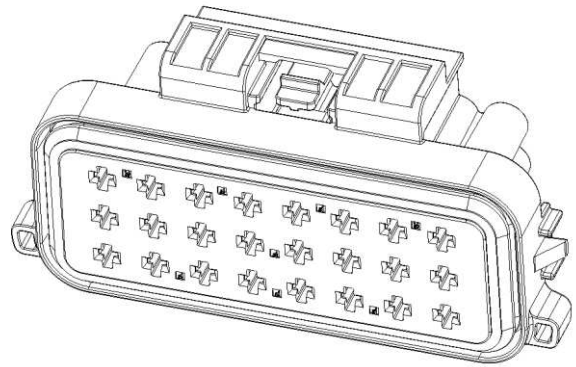

Figure 26  
2318967-2

### 3.8 Fuse Box Clips Mounting

#### 3.8.1 Sheet metal clips mounting

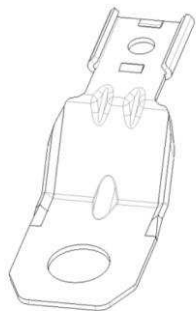

Figure 27  
1027-003-1200  
1027-004-1200  
1027-005-1200

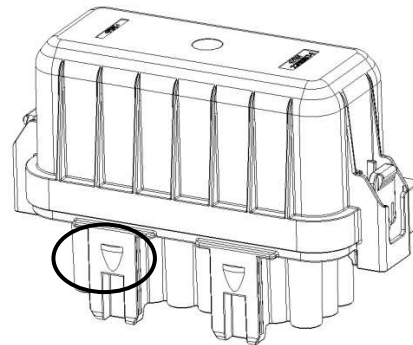

Figure 28  
Raised bump lock. One-time installation, cannot be removed after installation.

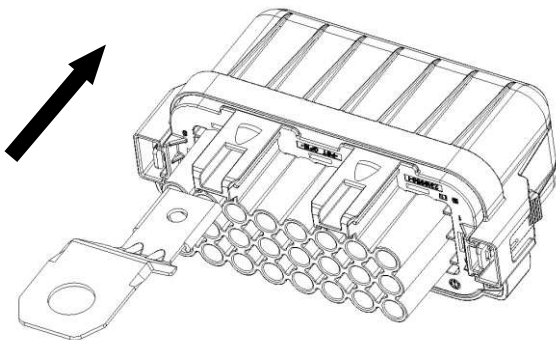

Figure 29  
Insert the fuse box housing on the sheet metal mounting clip as shown in Figure 29. The clip is fixed on the vehicle body.

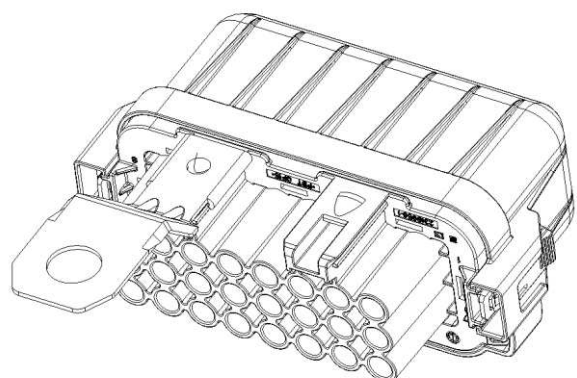

Figure 30  
shows the fuse box mounted on the sheet metal mounting clip. Mount clip to the second mounting feature also.

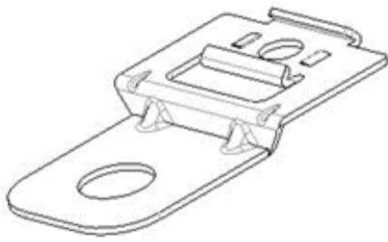

Figure 31  
1027-008-1200  
1027-009-1200  
1027-017-1200

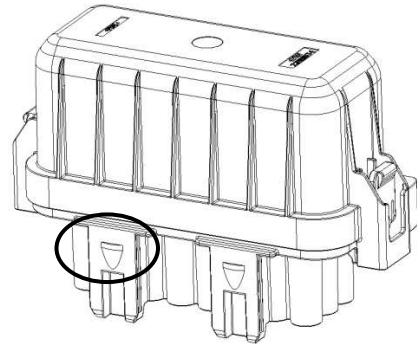

Figure 32  
Insert the fuse box housing on the sheet metal mounting clip as shown in Figure 32. The clip is fixed on the vehicle body.

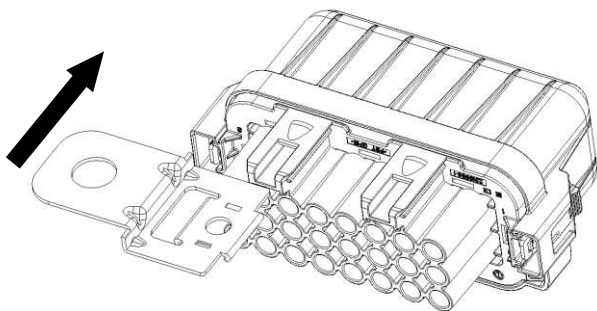

Figure 33  
Insert the fuse box housing on the sheet metal mounting clip as shown in Figure 33. The clip is fixed on the vehicle body.

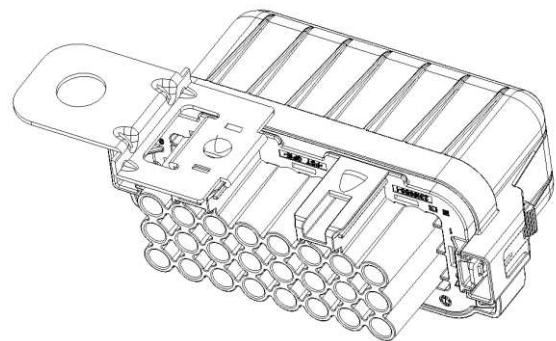

Figure 34  
shows the fuse box mounted on the sheet metal mounting clip. Mount clip to the second mounting feature also.

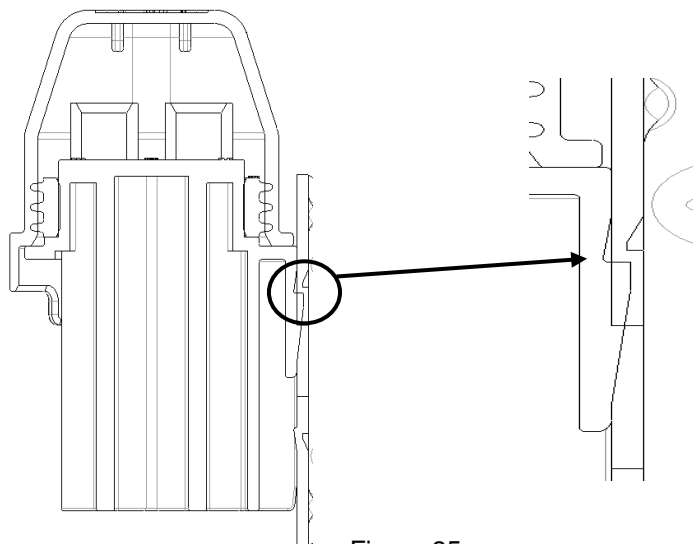
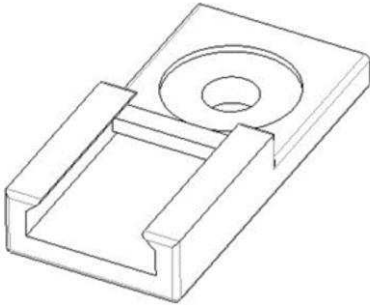
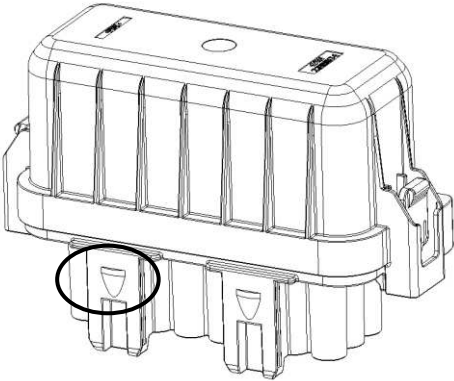
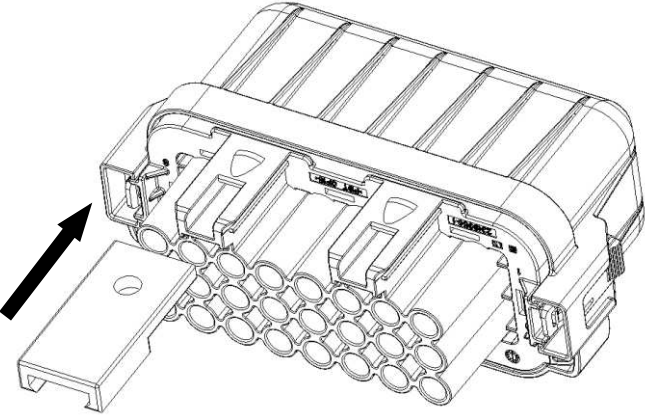
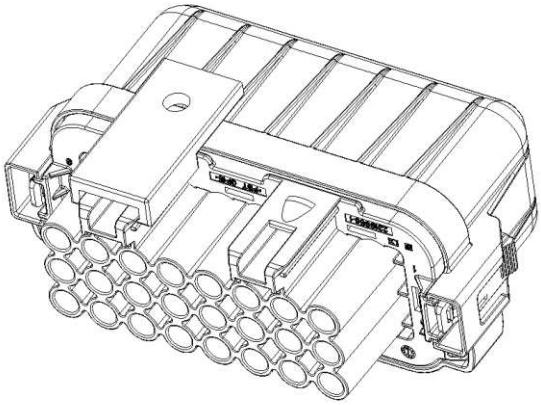
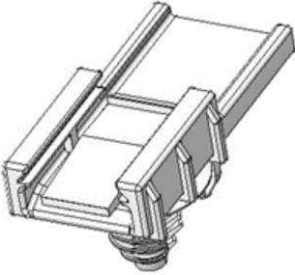
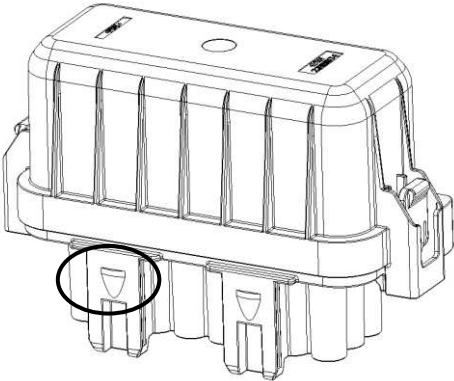
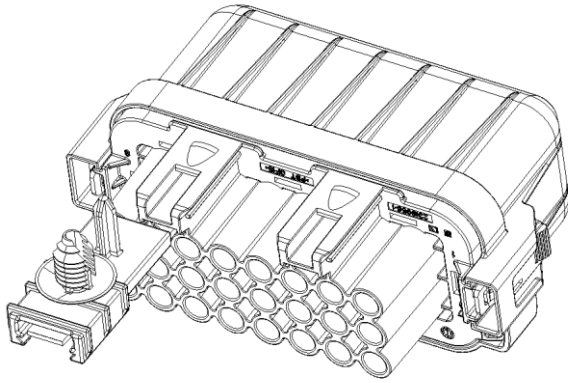

Figure 35

Figure 35 shows the engaged position of mounting clip to the raised bump in the housing.

3.8.2 Plastic clips mounting

	
<p>Figure 36 1011-026-0205</p>	<p>Figure 37 Raised bump lock. One-time installation, cannot be removed after installation.</p>
	
<p>Figure 38 Insert the fuse box housing on the plastic clip as shown in Fig. 38. The clip is fixed on the vehicle body. An audible click sound is to ensure the proper mounting clip.</p>	<p>Figure 39 shows the fuse box mounted on the Plastic mounting clip. Mount plastic clip to the second mounting feature also.</p>
	
<p>Figure 40 1011-310-0205</p>	<p>Figure 41 Raised bump lock One-time installation, cannot be removed.</p>



**Figure 42**  
 Insert the fuse box housing on the plastic clip as shown in Fig. 42. The clip is fixed on the vehicle body. An audible click sound is to ensure the proper mounting clip.

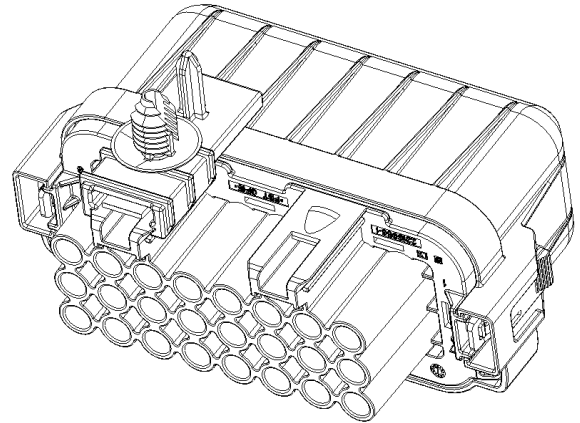

**Figure 43**  
 shows the fuse box mounted on the mounting clip. Mount clip to the second mounting feature also.



**Figure 44**  
 1924487-1, 2 and 3

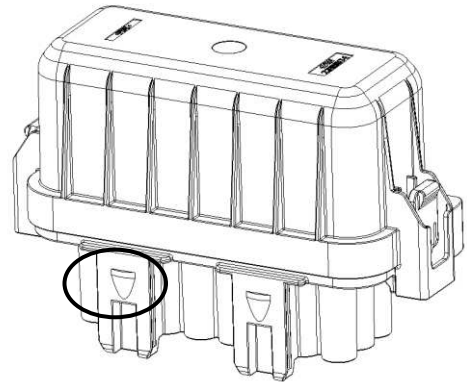

**Figure 45**  
 Raised bump lock. One-time installation, cannot be removed after installation.

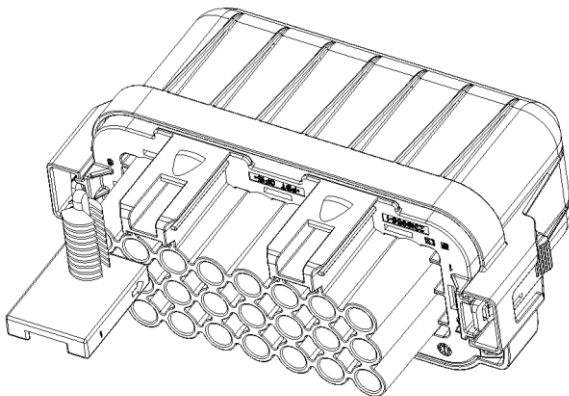

**Figure 46**  
 Insert the fuse box housing on the plastic clip as shown in Fig. 46. The clip is fixed on the vehicle body. An audible click sound is to ensure the proper mounting clip.

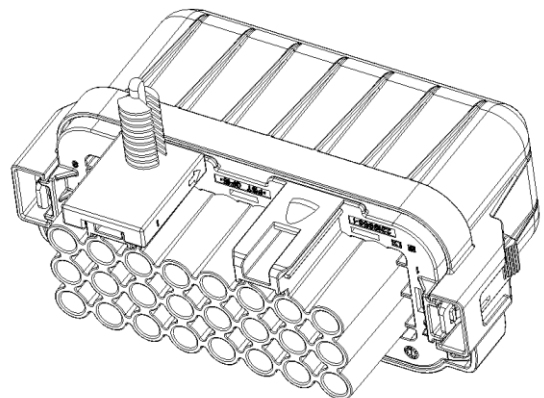

**Figure 47**  
 shows the fuse box mounted on the mounting clip. Mount clip to the second mounting feature also.

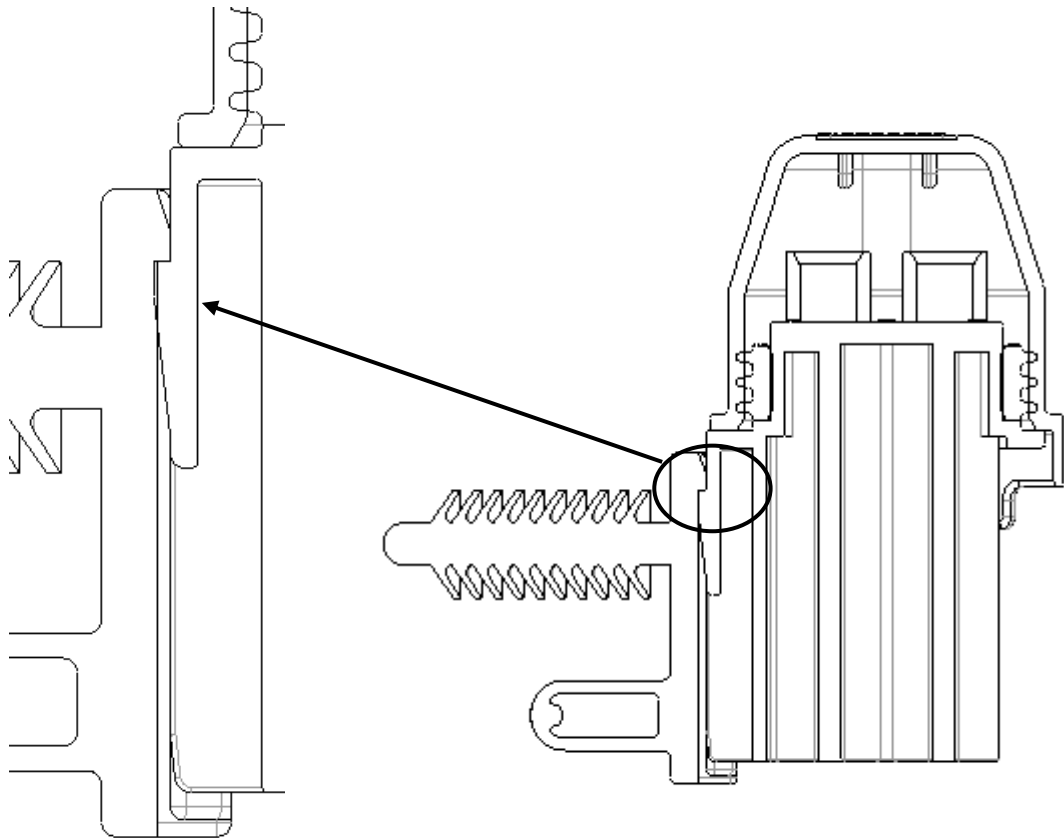
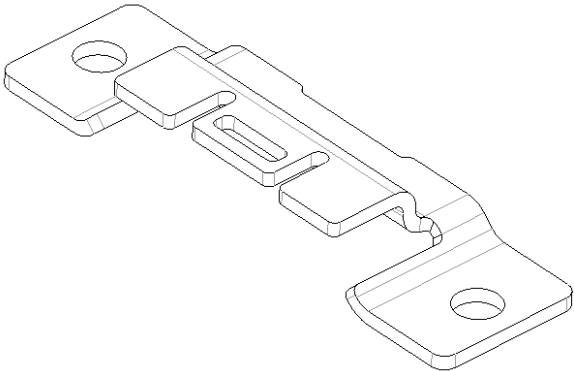
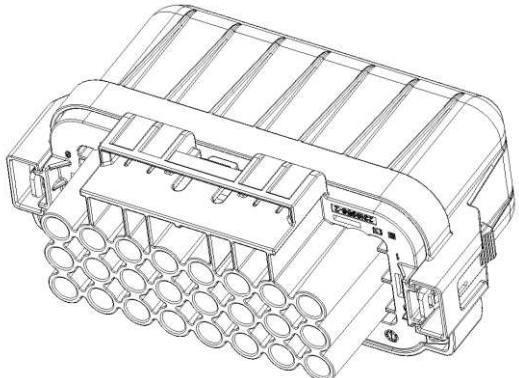
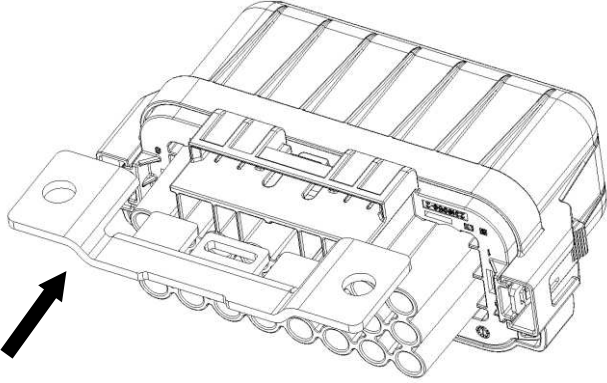
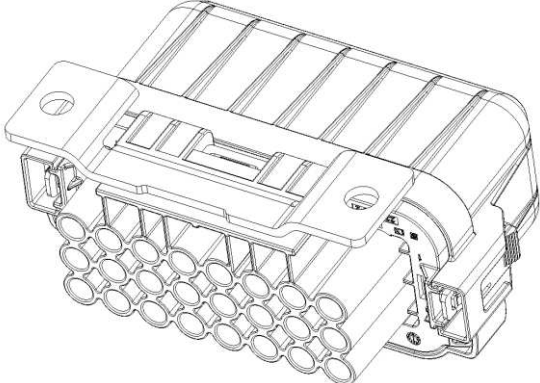

Figure 48

Figure 48 shows the engaged position of mounting clip to the raised bump in the housing.



### 3.9 Little Fuse Box Clips Mounting

	
<p>Figure 49 Little fuse Mounting Bracket</p>	<p>Figure 50</p>
	
<p>Figure 51 Insert the fuse box housing on the little fuse clip as shown in Fig. 51. The clip is fixed on the vehicle body. An audible click sound is to ensure the proper mounting clip.</p>	<p>Figure 52 shows the fuse box mounted on the mounting clip.</p>

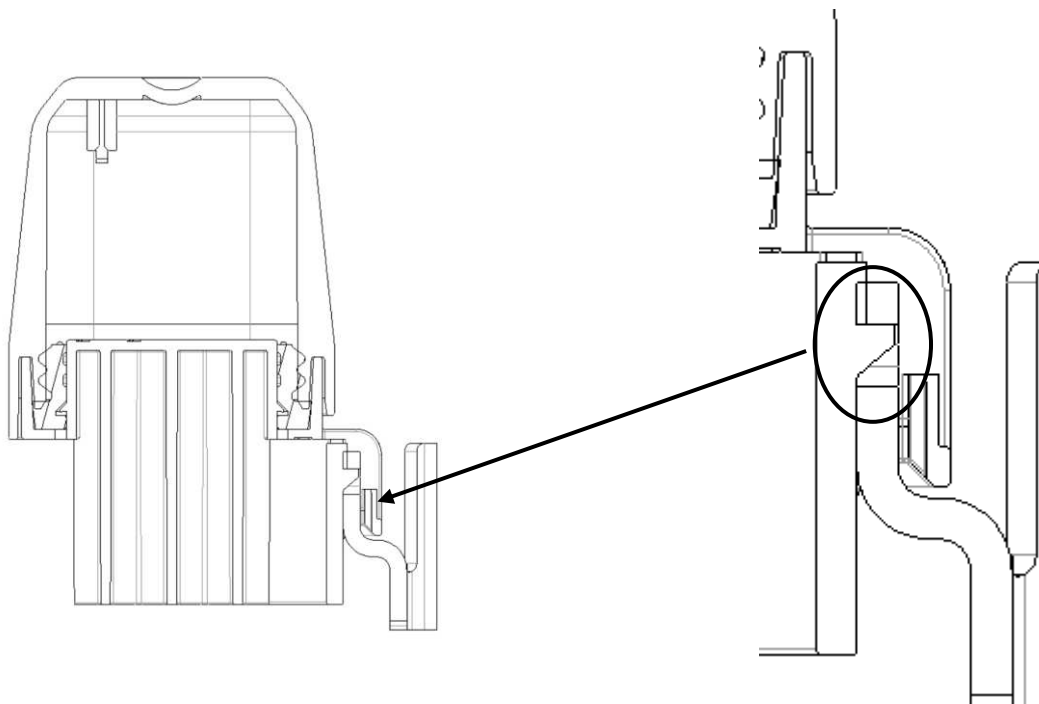

Figure 53 shows the engaged position of Little fuse clip to the latch in the housing.

#### 4. APPLICABLE RELAY

ISO 280 Micro Relay and ultra-micro Relay is applicable with Fuse and Relay Housing Assembly.