



72 WAY BCM CONNECTOR

TABLE OF CONTENT

1	GENERAL.....	2
1.1	PURPOSE	2
1.2	CUSTOMER DRAWINGS	2
1.3	DELIVERY CONDITION.....	2
1.3.1	72 WAY CONNECTOR CODINGS	3
1.3.2	TERMINALS FOR 72 WAY CONNECTOR.....	4
2.	72 WAY CONNECTOR.....	4
2.1	ASSEMBLY OF THE 72 WAY CONNECTOR.....	4
2.2	TERMINAL INSERTION INSTRUCTION	5
2.3	TPA GENERAL INFORMATION	7
2.3.1	TPA INSERTION INFORMATION - FROM PRE-LOCK TO END-LOCK POSITION	7
2.3.2	TPA REMOVAL INSTRUCTION (SERVICE CASE)	9
2.4	TERMINAL REMOVAL INSTRUCTIONS.....	12
2.5	APPLICABLE WIRES.....	13
2.6	COVER INSERTION / REMOVAL INSTRUCTION.....	14
2.6.1	COVER INSERTION INSTRUCTION.....	14
2.6.2	CABLE STRIP INSTRUCTION.....	16
2.6.3	COVER REMOVAL INSTRUCTION.....	17
2.7	72 WAY CONNECTOR INTERFACE INSERTION / REMOVAL INSTRUCTION.....	19
2.7.1	72 WAY CONNECTOR INTERFACE INSERTION	19
2.7.2	72 WAY CONNECTOR / INTERFACE UNLOCK AND REMOVAL FROM BACKSIDE	23
2.7.3	72 WAY CONNECTOR / INTERFACE UNLOCK AND REMOVAL FROM FRONTSIDE	25

1 GENERAL

1.1 PURPOSE

THIS SPECIFICATION DESCRIBES HOW YOU HANDLE THE 72 WAY CONNECTOR COMPONENTS.

1.2 CUSTOMER DRAWINGS

THIS APPLICATION SPECIFICATION IS BASED ON THE LATEST VALID CUSTOMER DRAWING

C-2287336 72 WAY CONNECTOR

INTERFACE SPECIFICATION

114-94384 72 WAY CONNECTOR

1.3 DELIVERY CONDITION

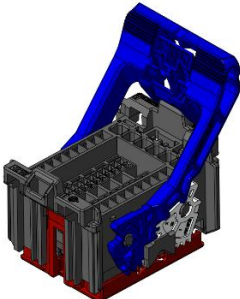
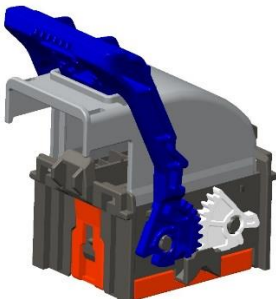
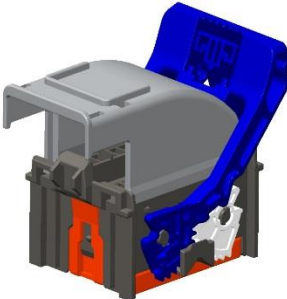

Table 1: lever position during delivery condition

Delivery Position From TE to harness maker	Unmated Position From harness maker to OEM	Mated Position (by usage)
		
Lever in END-LOCK position TPA in PRE-LOCK position Cover unmounted	Lever in PRE-LOCK Position TPA in END-LOCK position Cover mounted	Lever in END-LOCK Position TPA in END-LOCK position Cover mounted
This is the position in which the part will be shipped to harness maker.	Harness maker loads terminals and assembles Wire Dress cover. Moves lever to the pre-mate position.	Operator mates to BCM by rotating lever to final position.

1.3.1 72 WAY CONNECTOR CODINGS

<p>72 WAY CONNECTOR ASSYEMBLY</p>	<p>1-2287336-1 COLOR: BLACK</p> <p>1-2287336-2 COLOR: GRAY</p>	
<p>72 WAY COVER TO BE ORDERED SEPARATELY</p>	<p>1-2287341-2</p>	

1.3.2 TERMINALS FOR 72 WAY CONNECTOR

0.64 GENERATION Y	USEABLE CONTACTS SHOWN ON TE CUSTOMER DRAWING 2287336	
MX150 OR YAZAKI 1.5	USEABLE CONTACTS SHOWN ON TE CUSTOMER DRAWING 2287336	
FCI APEX 2.8 OR SUMITOMO 2.8	USEABLE CONTACTS SHOWN ON TE CUSTOMER DRAWING 2287336	

2. 72 WAY CONNECTOR

2.1 ASSEMBLY OF THE 72 WAY CONNECTOR

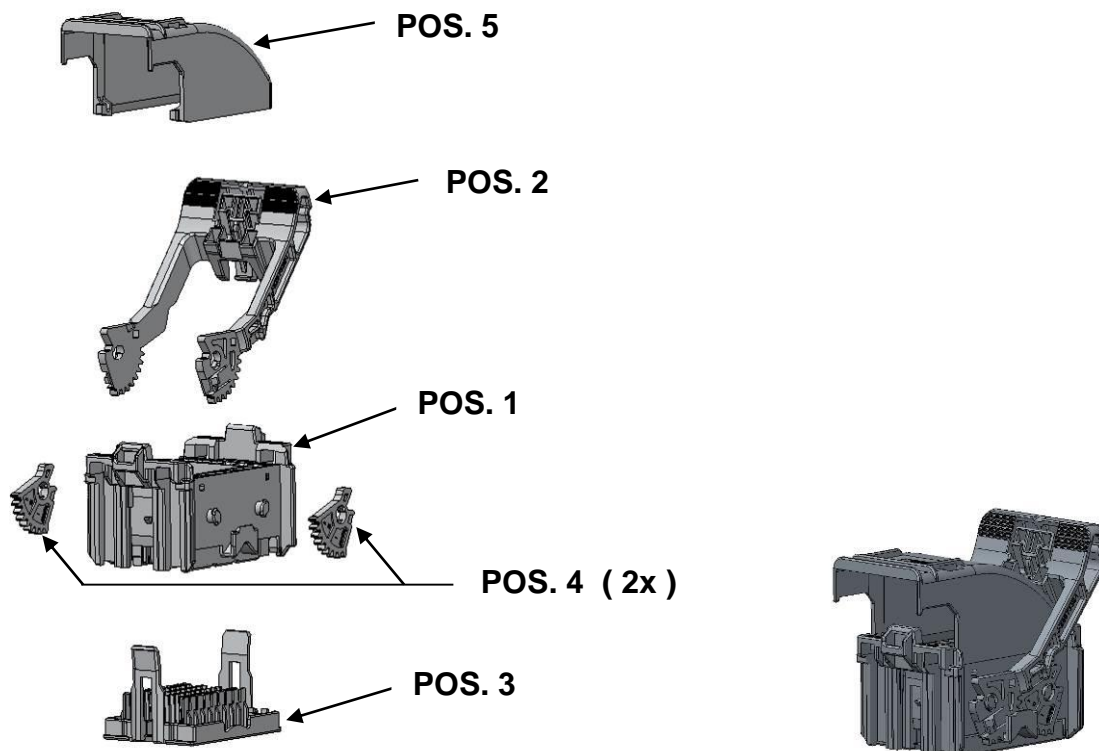

- POS. 1 HOUSING - 72 WAY UNSEALED HYBRID PLUG
- POS. 2 LEVER - 72 WAY UNSEALED HYBRID PLUG
- POS. 3 TPA - 72 WAY UNSEALED HYBRID PLUG
- POS. 4 PINION GEAR - 72 WAY UNSEALED HYBRID PLUG
- POS. 5 COVER - 72 WAY UNSEALED HYBRID PLUG

2.2 TERMINAL INSERTION INSTRUCTION



*DURING TERMINAL INSERTION THE LEVER SHOULD NOT BE MOVED OUT OF THE **END-LOCK POSITION** (DELIVERY CONDITION FROM TE TO HARNESSMEKER SEE FOR REFERENCE CHAPTER 1.3)*

INSERT **MX150 OR YAZAKI 1.5** TERMINALS STRAIGHT INTO CAVITIES AND NOTE ORIENTATION THE CONTACT POLARISATION TO THE CAVITY POLARISATION

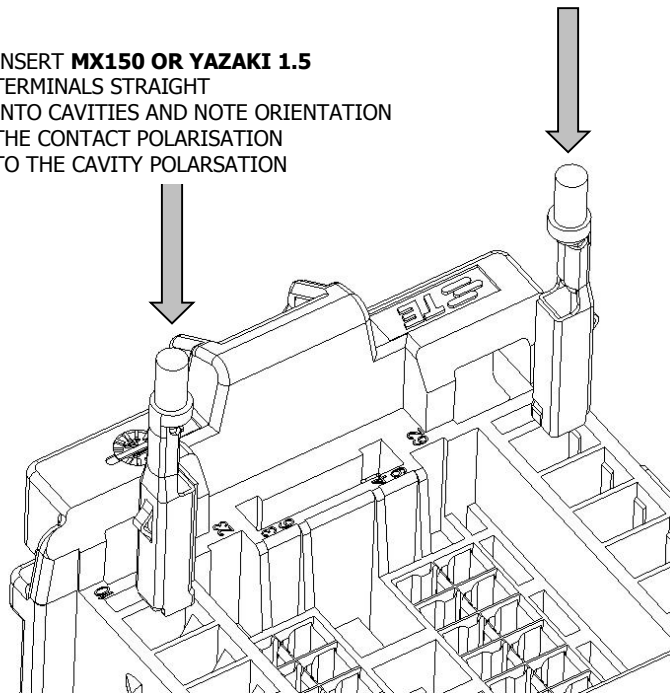

ORIENTATION FEATURE ON **MX150 OR YAZAKI 1.5** TERMINAL

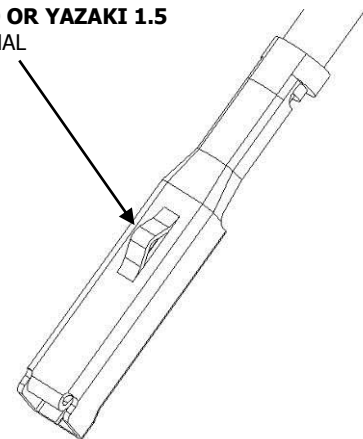

INSERT **GENERATION 0.64** TERMINALS STRAIGHT INTO CAVITIES AND NOTE ORIENTATION THE CONTACT POLARISATION TO THE CAVITY POLARISATION

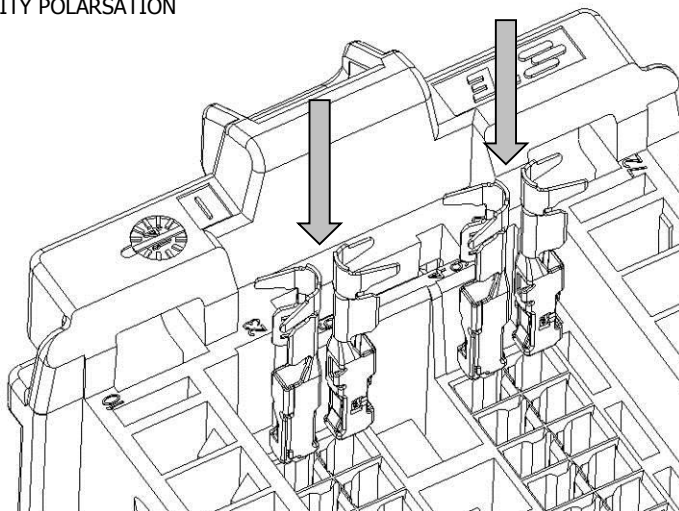

ORIENTATION FEATURE ON **GENERATION 0.64** TERMINAL

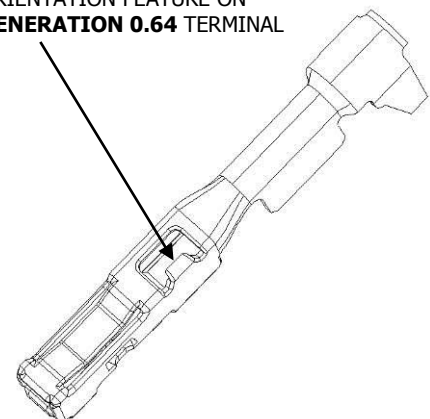

OUTER TERMINAL ROW ORIENTED 180° FROM INSIDE TERMINAL ROW

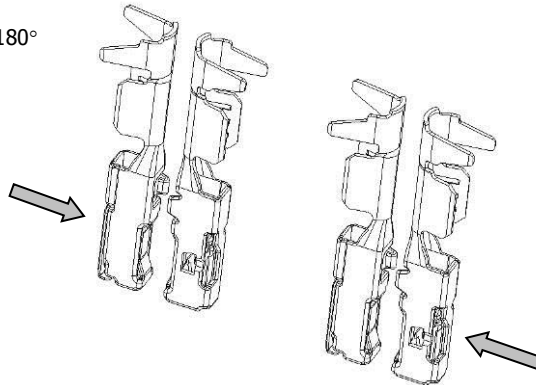

INSERT **SUMITOMO 2.8 OR FCI APEX 2.8** TERMINALS STRAIGHT INTO CAVITIES.

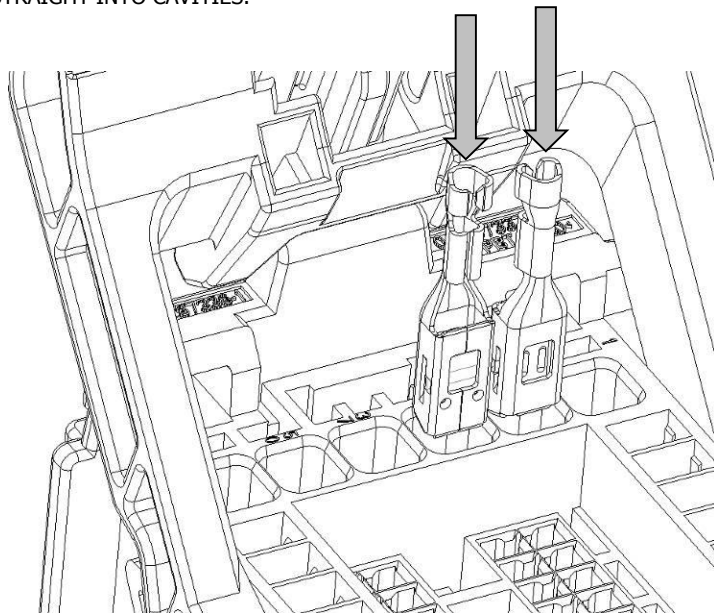

NO ORIENTATION FEATURE ON **SUMITOMO 2.8 OR FCI APEX 2.8** TERMINAL
BOTH ORIENTATIONS 0° AND 180° ALLOWED

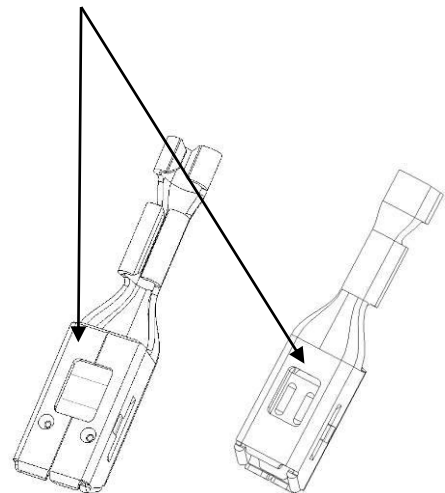

INSERT TERMINALS UNTIL AN AUDIBLE '**CLICK**' IS HEARD OR FELT
TERMINALS ARE NOW LOCKED INTO THE CAVITY



ASSURE THAT TERMINALS ARE FULLY LOCKED INTO CAVITIES

2.3 TPA GENERAL INFORMATION

For the terminal position assurance (TPA) three different mating position exists:

- TPA in End-lock position (delivery condition from harness maker to OEM)
- TPA in Pre-lock (delivery condition from TE to harness maker)
- Removed position (service of contacts)

TPA - END-LOCK position	TPA - PRE-LOCK position	TPA - REMOVED position
<p>A) working position</p>  <p>TPA align</p>	<p>B) as delivered</p>  <p>4.2mm</p>	<p>C) terminal service</p>  <p>TPA lose</p>

Figure 1: three different TPA position, A) End-lock - , B) Pre-lock - and C) Removed – position

2.3.1 TPA INSERTION INFORMATION - FROM PRE-LOCK TO END-LOCK POSITION

After terminal insertion, push both TPA latches to each other as shown in Figure 2 (step 1). If both locking features are unlocked, you can push the TPA into the End-lock position, as show in Figure 3 (step 2). If the TPA is complete installed, both locking latches should be locked as shown in Figure 4 (step 3).

Step 1:

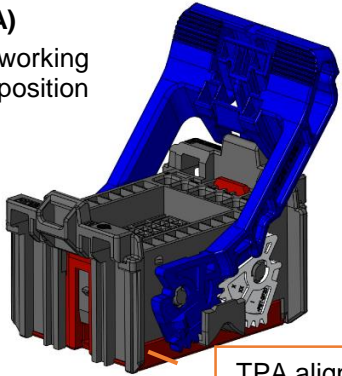
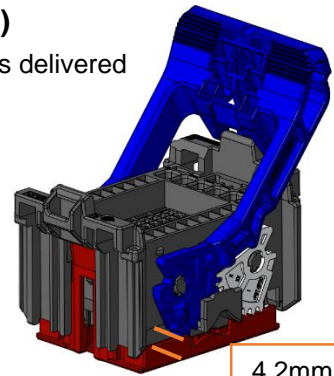
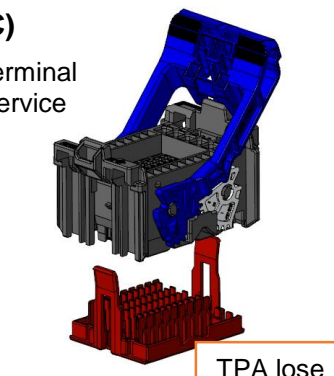
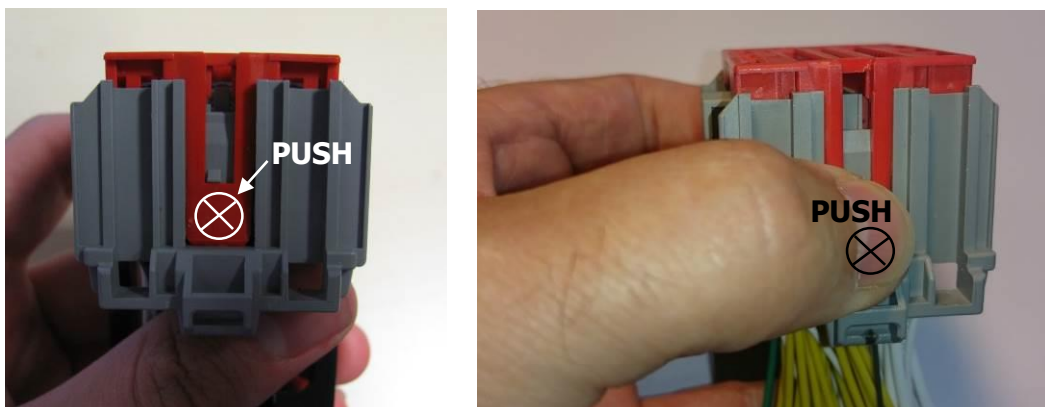

Figure 2: Unlock TPA latch in order to release TPA for insertion

Step 2:

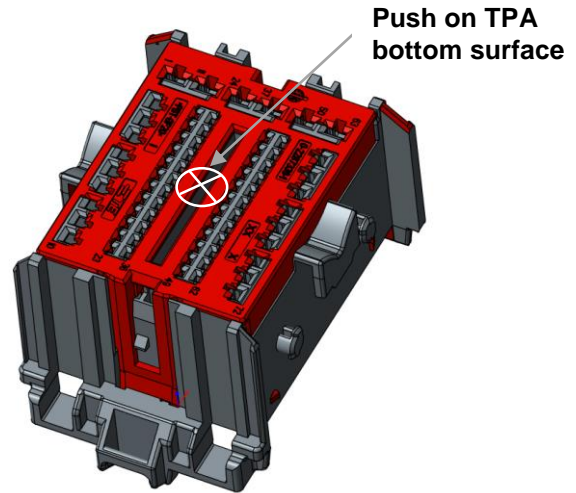
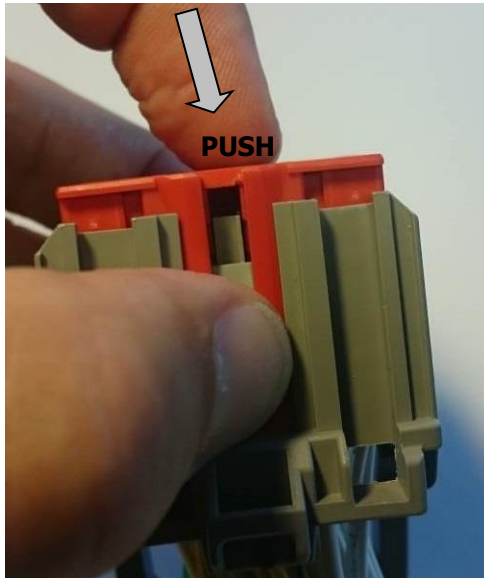

Figure 3: Unlocking TPA release locking feature with thumb and ring finger, then push the TPA bottom surface to the end-lock position

Step 3:

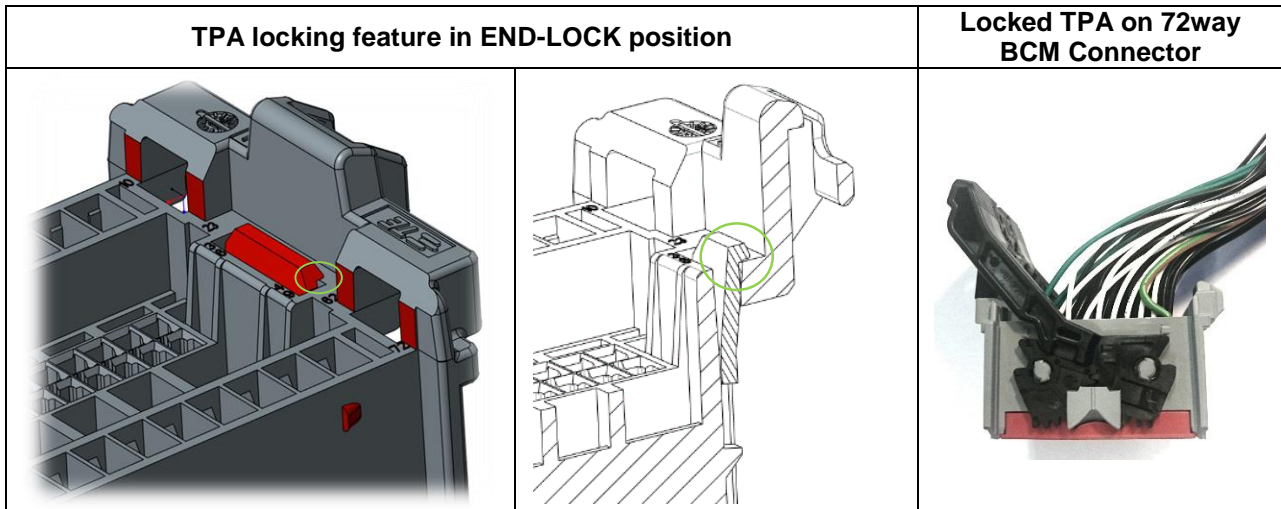

Figure 4: TPA in end-lock position with terminals installed



Make sure both locking feature are locked as shown in Figure 4

2.3.2 TPA REMOVAL INSTRUCTION - FROM END-LOCK TO REMOVED POSITION (SERVICE CASE)

In case for service, the operator should remove the TPA in 5 steps.

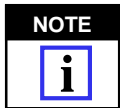

BEFORE TO REMOVE THE TERMINALS THE TPA MUST BE DISMANTLED UNLOCK THE TPA ON BOTH SIDES USING THE EXTRACTION TOOL 1452426-1

Remove the locking latch by using the extraction tool 1452426-1. Unlock both latches as shown in Figure 5. During the removal process the connector lever should not be moved. In the case that the lever was moved out of the end-lock position (see for reference Table 1) the operator should return the lever for lever unlocking as described in step one of chapter “2.6.3 cover removal instruction”.



*DURING TPA REMOVAL THE LEVER SHOULD NOT BE MOVED OUT OF THE **END-LOCK POSITION** (DELIVERY CONDITION FROM TE TO HARNESSMEKER SEE FOR REFERENCE CHAPTER 1.3)*

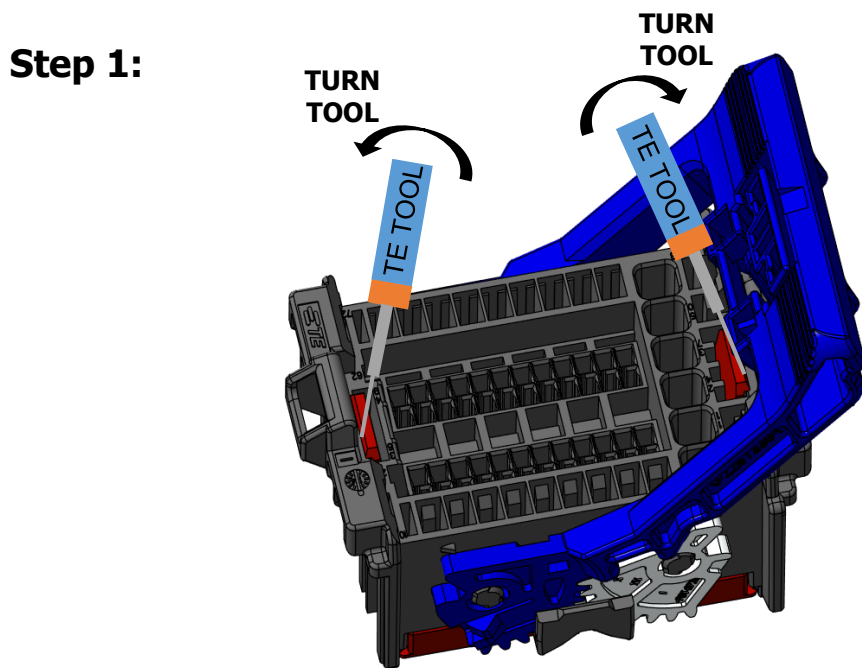

Figure 5: Unlock of TPA latch



IF THE LOCKING FEATURES ARE UNLOCKED YOU CAN PULL TPA TO PRESET POSITION.

Step 2:

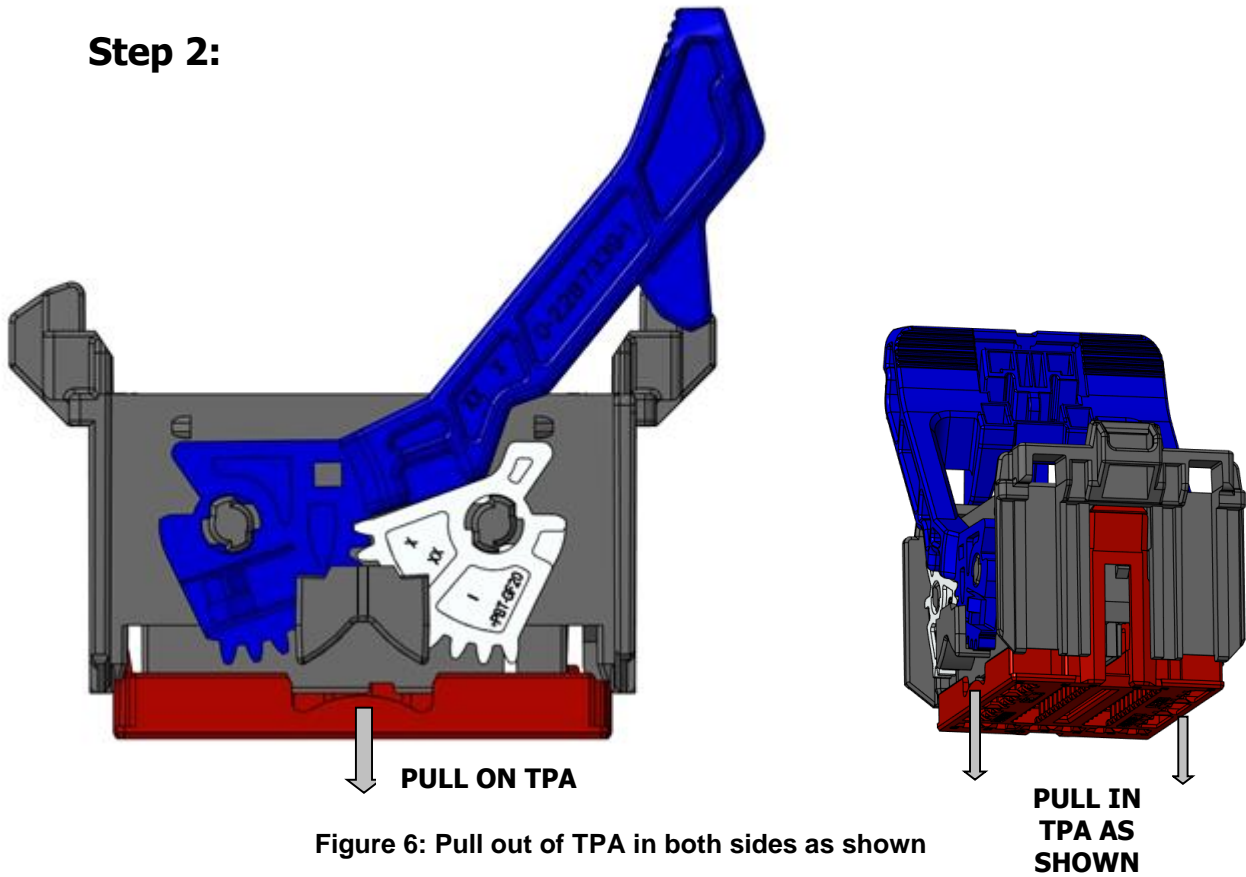

Figure 6: Pull out of TPA in both sides as shown

Step 3:

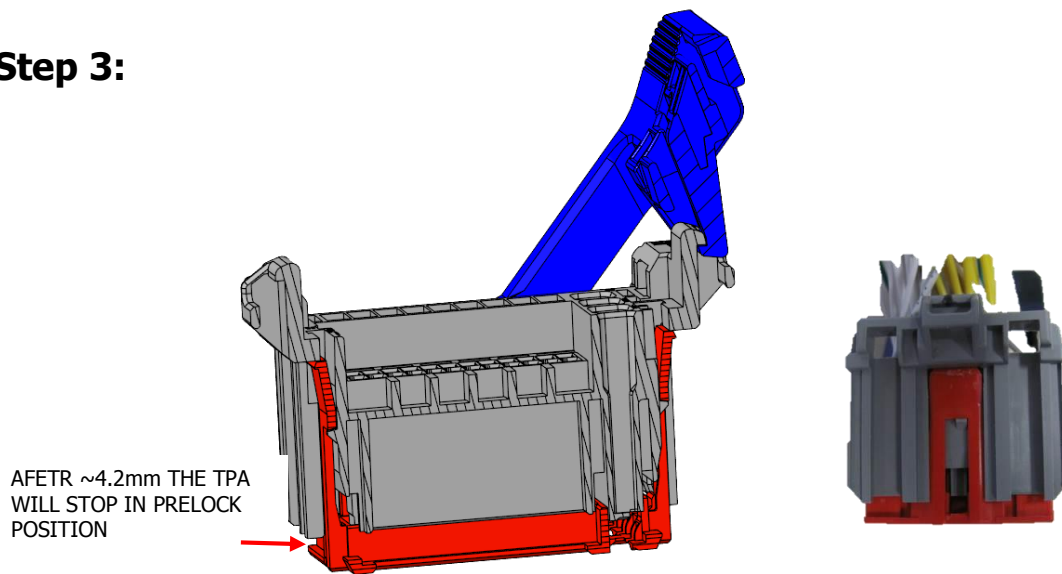
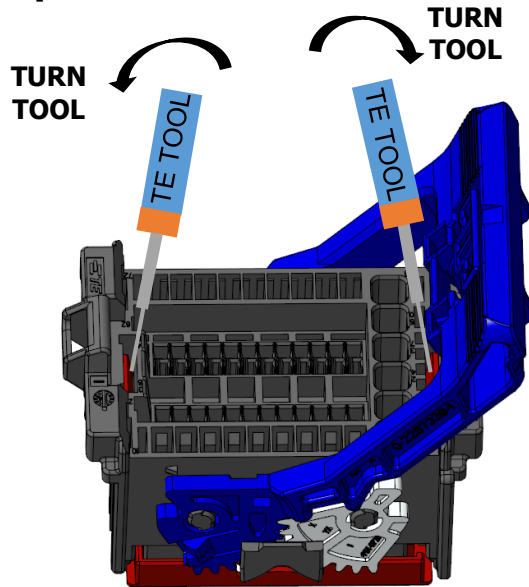

Figure 7: TPA will stop in pre-lock position as shown
 INSERT THE EXTRACTION TOOL 1452426-1 FROM THE TOP AND LEVERAGE TPA OVER THE LOCKING LATCH.

Step 4:



REMOVE TPA FULLY BRFORE UNMOUNT THE CONTACTS

Figure 8: Insert TE extraction tool TE PN 0-1452426-1

Step 5:

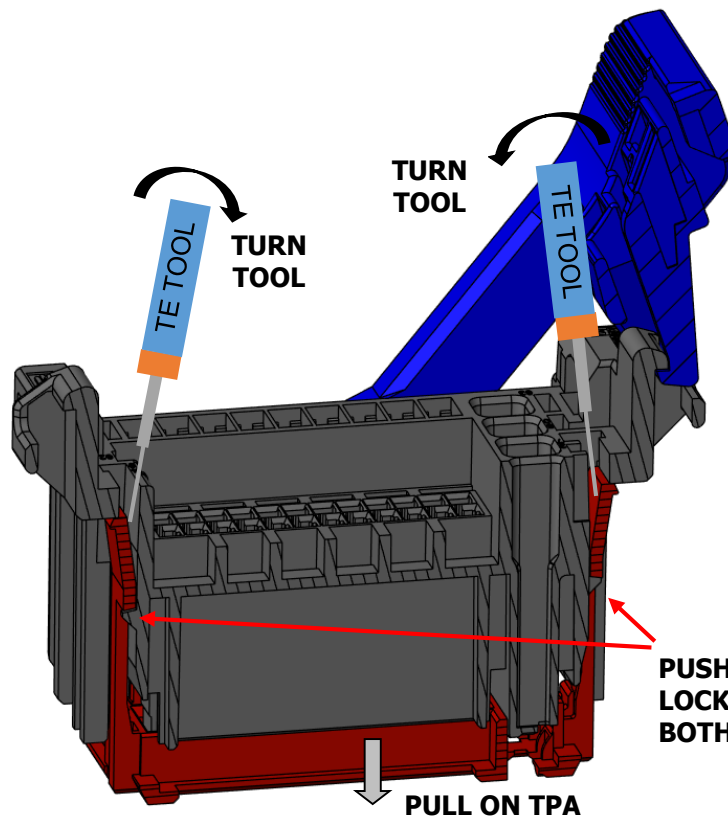

PUSH THE TPA OVER THE LOCKING FEATURES TO BOTH SIDES

Figure 9: Unlock locking latch from pre-lock position as shown



IF BOTH LOCKING LATCHES WERE BETTERED YOU CAN REMOVE THE TPA FROM HOUSING

2.4 TERMINAL REMOVAL INSTRUCTIONS



TPA NEEDS TO BE FULLY REMOVED BEFORE TERMINALS CAN BE REMOVED. HOW TO REMOVE THE TPA SEE CHAPTER "2.3.2 TPA REMOVAL INSTRUCTION - FROM END-LOCK TO REMOVED POSITION (SERVICE CASE)"

1. POSITION
THE EXTRACTION
TOOL 1452426-1
TO LOCKING FINGER

INSERT

2.

2. ROTATE
EXTRACTION
TOOL TO RELEASE
THE LOCKING
FINGER

1.

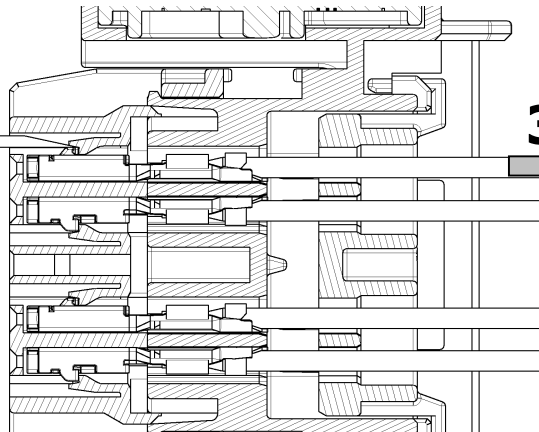

3.

3. PULL OUT
THE TERMINALS



*DURING TERMINAL REMOVAL THE CONNECTOR LEVER SHOULD NOT BE MOVED OUT OF THE **END-LOCK POSITION** (DELIVERY CONDITION FROM TE TO HARNESSMEKER SEE FOR REFERENCE CHAPTER 1.3)*

2.5 APPLICABLE WIRES

CONTACT SYSTEM	WIRE SIZE [mm ²]	CABLE INSULATION DIAMETER [mm]
0.64 mm TERMINAL	0,35 mm ²	1,4 -0,2 mm
	0,50 mm ²	1,6 -0,2 mm
	0,75 mm ²	1,9 -0,2 mm
1.50 mm TERMINAL	0,35 mm ²	1,4 -0,2 mm
	0,50 mm ²	1,6 -0,2 mm
	0,75 mm ²	1,9 -0,2 mm
	1,0 mm ²	2,1 -0,2 mm
	1,5 mm ²	2,4 -0,2 mm
2.80 mm TERMINAL	0,35 mm ²	1,4 -0,2 mm
	0,50 mm ²	1,6 -0,2 mm
	0,75 mm ²	1,9 -0,2 mm
	1,0 mm ²	2,1 -0,2 mm
	1,5 mm ²	2,4 -0,2 mm
	2,5mm ²	3,0 -0,3 mm
	5,0mm ²	4,0 -0,3 mm

2.6 COVER INSERTION / REMOVAL INSTRUCTION

2.6.1 COVER INSERTION INSTRUCTION



*DURING COVER INSERTION THE CONNECTOR LEVER SHOULD NOT BE MOVED OUT OF THE **END-LOCK POSITION** (DELIVERY CONDITION FROM TE TO HARNESSMEKER SEE FOR REFERENCE CHAPTER 1.3)*

Step 1:

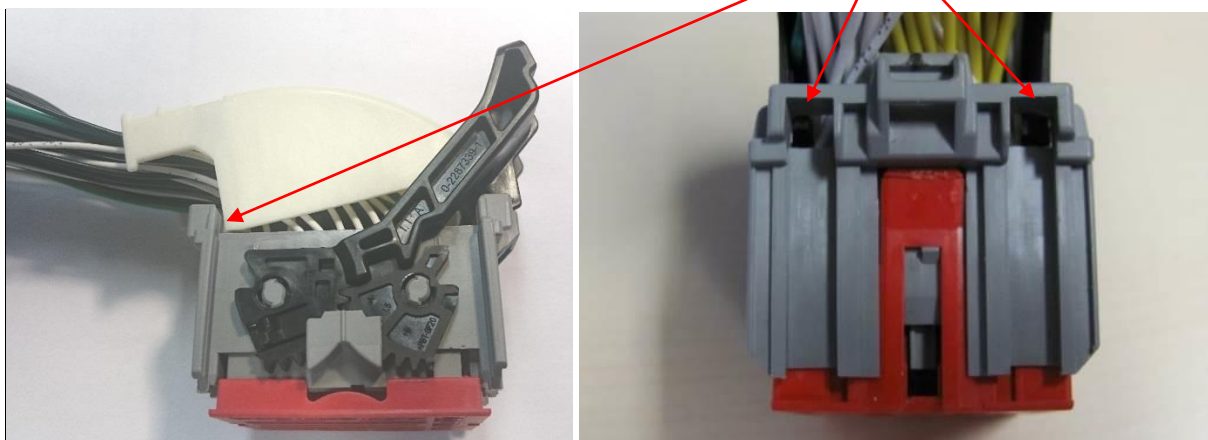

Figure 10: Rotate and place the cover as shown into the locking windows as shown

Step 2:

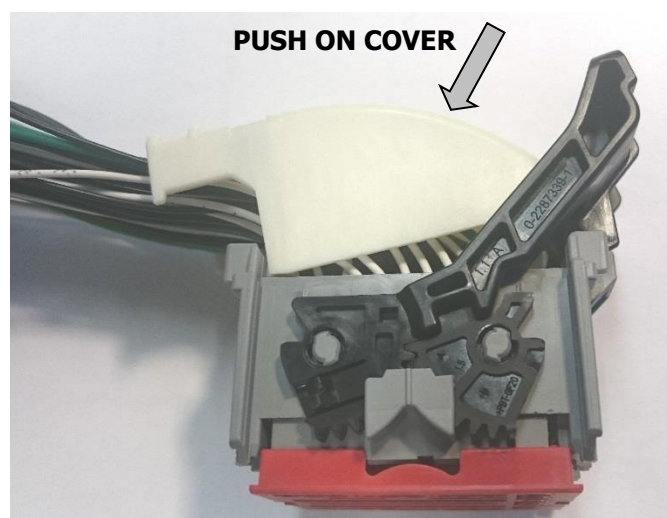

Figure 11: Press the cover into end-lock position until it locks (see next page)

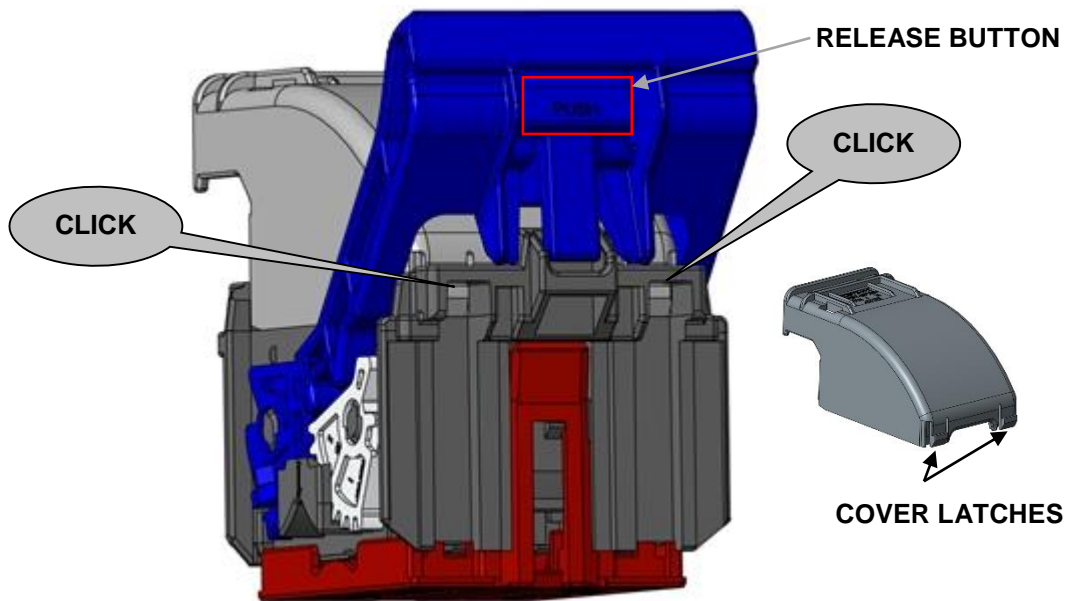
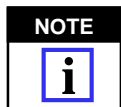

Figure 12: Both cover latches will lock into the locking windows



After cover insertion, push the release button (shown in Figure 12) and turn the lever into the PRE-LOCK position shown in Figure 13

Step 4:

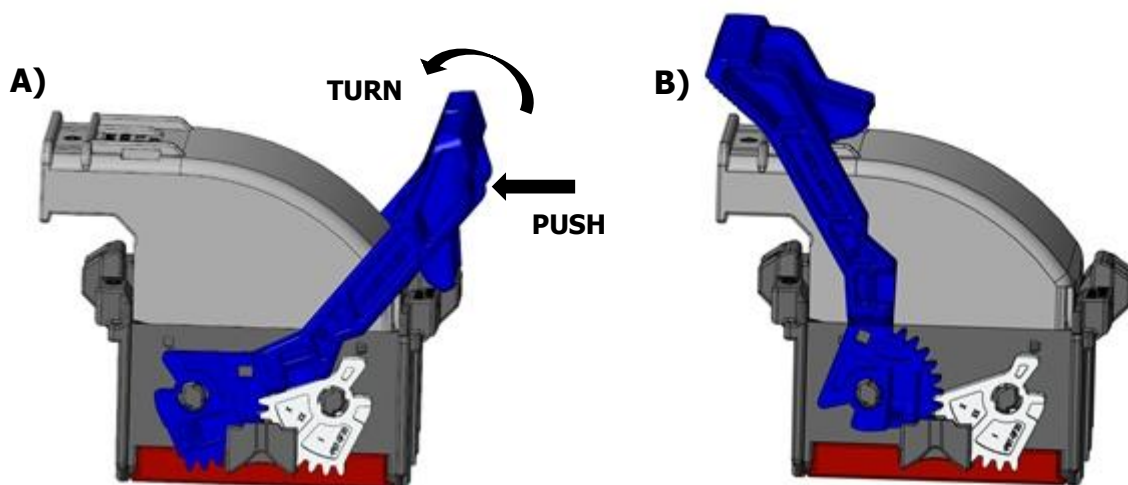

Figure 13: A) Cover in END-LOCK position

B) cover in PRE-LOCK position

2.6.2 CABLE STRIP INSTRUCTION

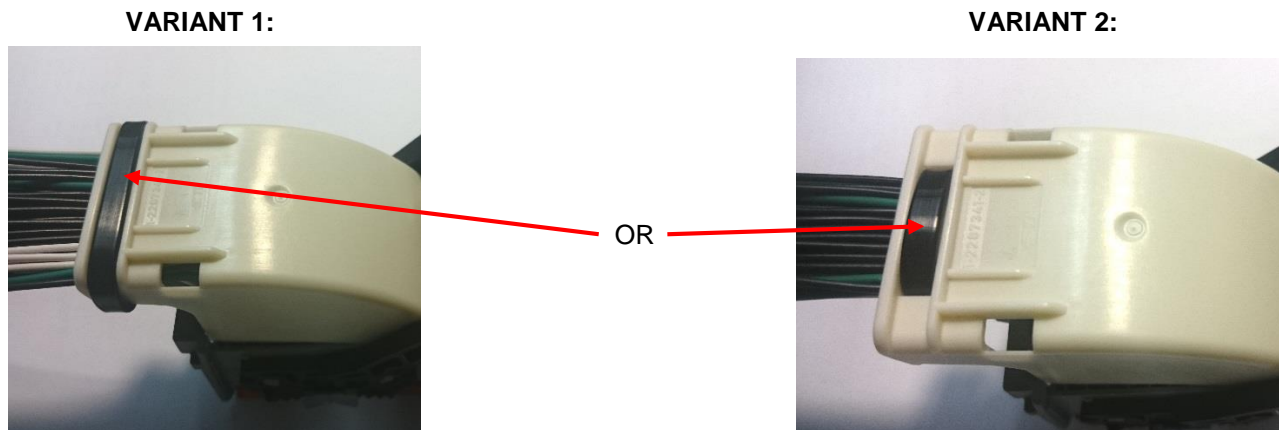
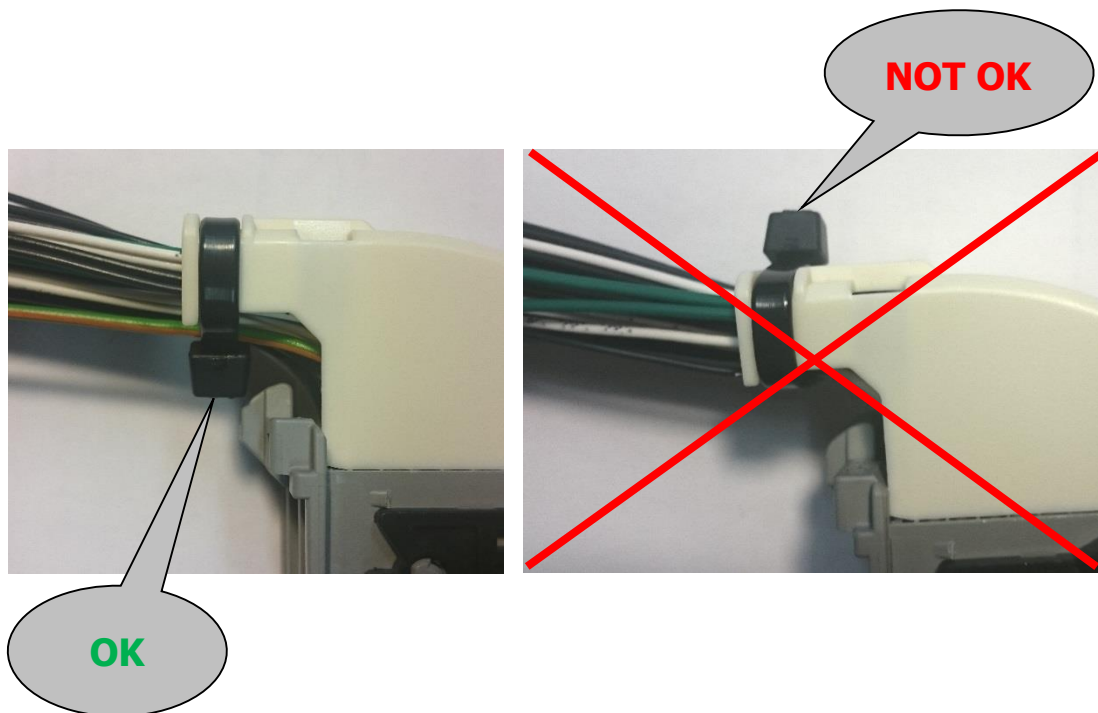

Figure 14: Variations of cable strip insertion



CABLE STRIP MUST BE TIGHTENED. THE MAX ALLOWED CABLE STRIP WIDE IS 4.5mm

2.6.3 COVER REMOVAL INSTRUCTION



IN SERVICE CASE THE CONNECTOR LEVER HAS TO BE MOVED IN END-LOCK POSITION. IF THE LEVER IS NOT IN END-LOCK POSITION, FOLLOW STEP 1 BELOW. IF THE LEVER IS ALLREADY IN PRE-LOCK POSITION PROCEED WITH SETP 2.

Step 1:

A) LEVER IN PRE-LOCK POSITION:

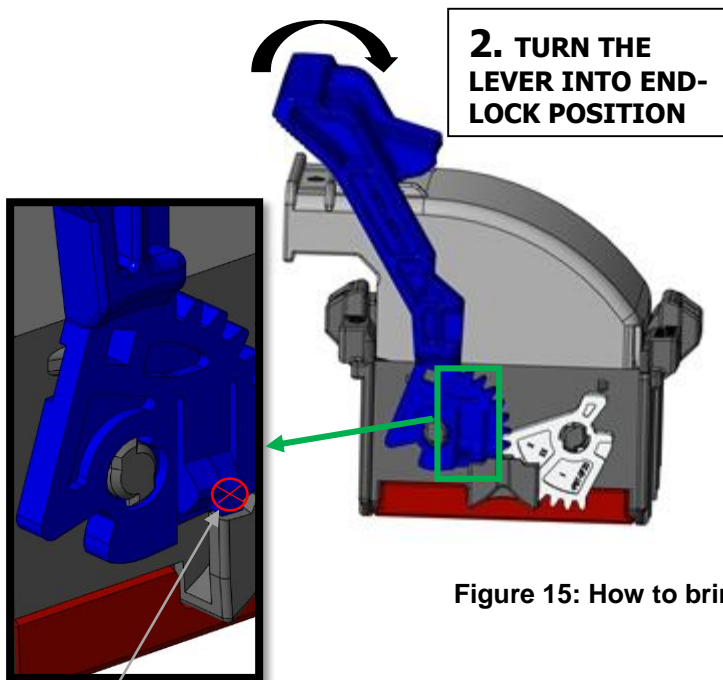

B) LEVER IN END-LOCK POSITION:

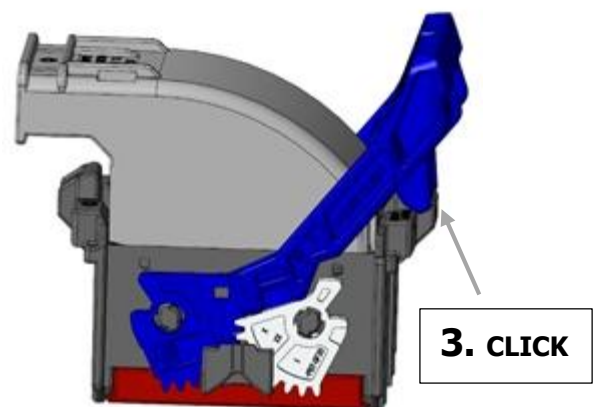

Figure 15: How to bring Lever from pre-lock to end-lock position

Step 2:

UNLOCK THE COVER BY USING A SMALL SCREW DRIVER AS SHOWN. IF BOTH LOCKING LATCHES ARE UNLOCKED YOU CAN REMOVE THE COVER

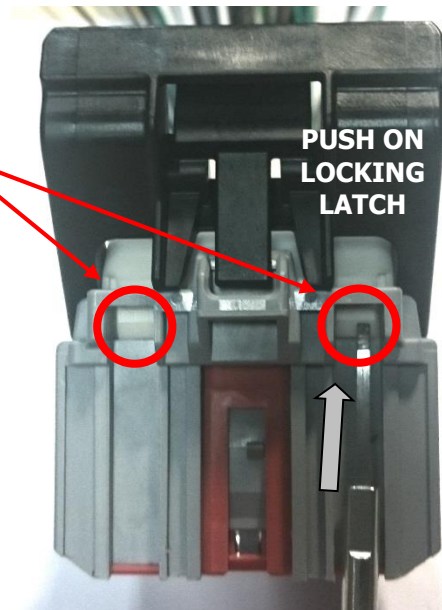

Figure 16: Unlock of wire dress cover

Step 3:

Figure 17: Removal of wire dress cover



IF BOTH LOCKING LATCHES BETTERED YOU CAN REMOVE THE COVER FROM THE HOUSING

2.7 72 WAY CONNECTOR INTERFACE INSERTION / REMOVAL INSTRUCTION

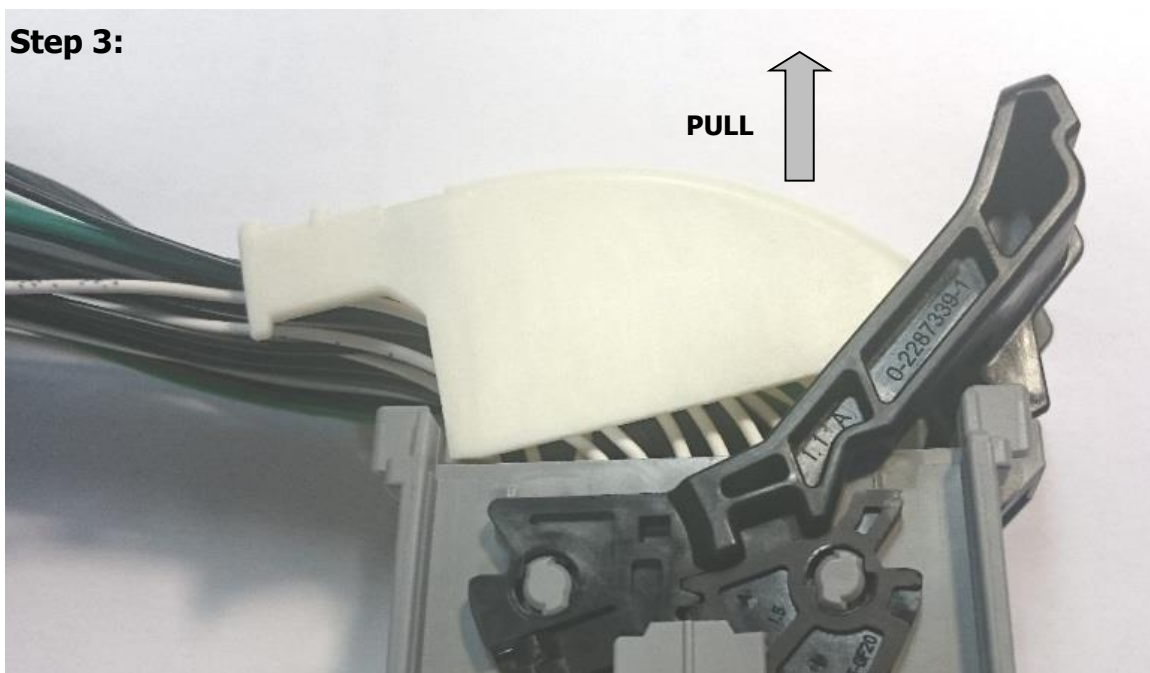
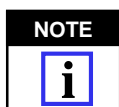
2.7.1 72 WAY CONNECTOR INTERFACE INSERTION



IF THE TERMINALS ARE INSTALLED, TPA IN END-LOCK POSITION, COVER MOUNTED AND THE CABLE STRIP IS TIGHTENED PUT THE LEVER INTO PRELOCK POSITION. THE CONNECTOR CAN BE MOUNTED WITH LEVER IN PRELOCK POSITION ONLY!



Step 1:- check lever position

72 WAY CONNECTOR **ENDLOCK POSITION**

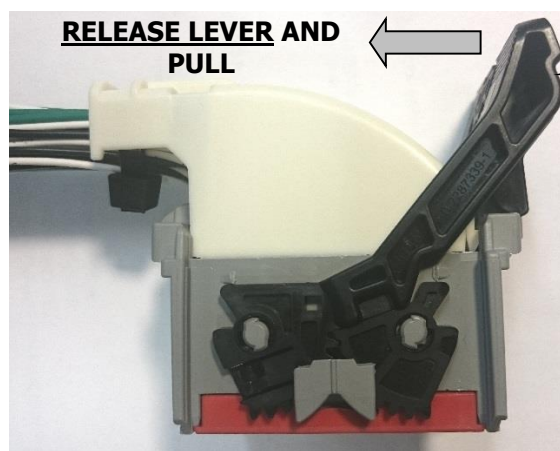

MOVE LEVER TO MOUNTING POSITION



PUSH RELEASE BUTTON

72 WAY CONNECTOR DOES NOT FIT TO INTERFACE WITH THE LEVER IN THIS POSITION

72 WAY CONNECTOR **PRELOCK POSITION**

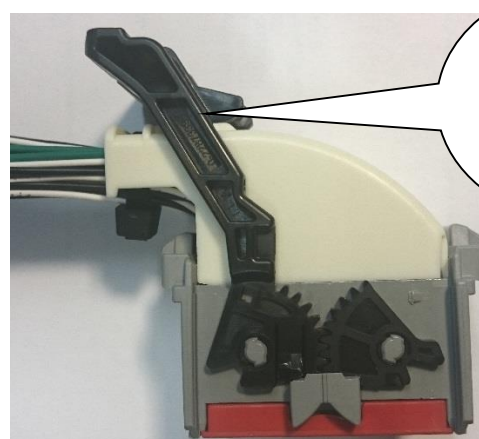

LEVER POSITION BEFORE CONNECTOR MOUNTING

LEVER POSITION OK 72 WAY CONNECTOR READY TO MATE TO THE INTERFACE

Figure 18: Check if lever is in the correct position

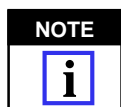

HOW TO RELEASE THE LEVER FROM END-LOCK POSITION SEE CHAPTER 2.7.2. MAKE SURE THE RELEASE FEATURE IS NOT BROKEN BEFORE INSERTION INTO INTERFACE.

CODING A

CODING B

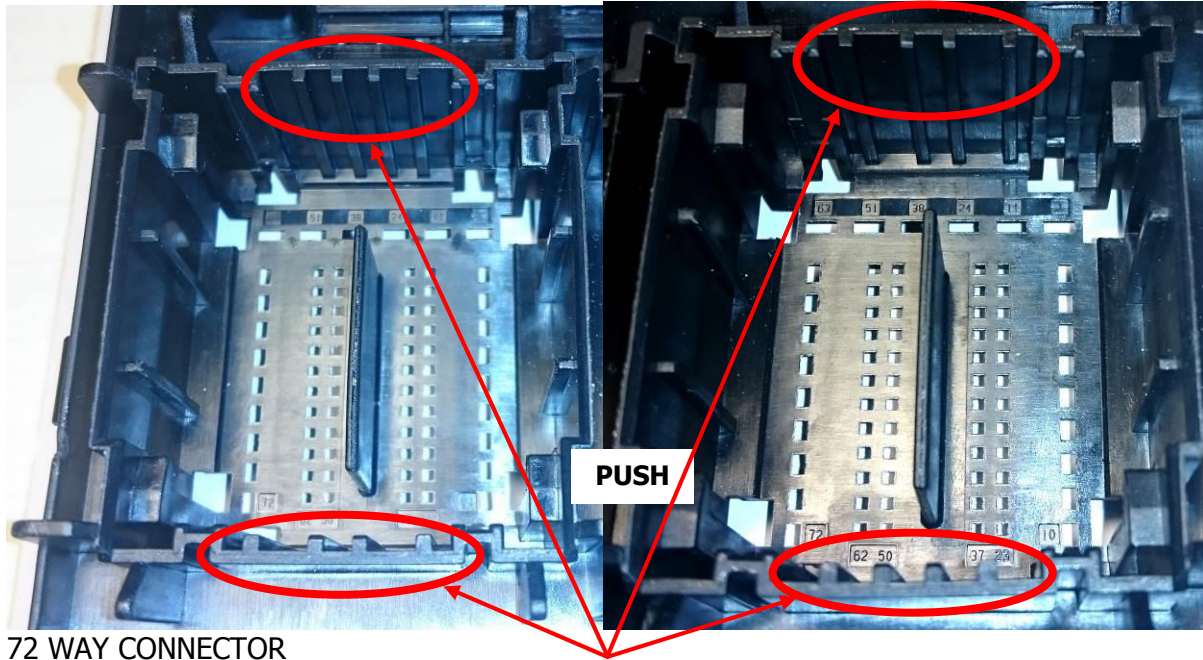

72 WAY CONNECTOR

INTERFACE CODING RIBS

Figure 19: 72 WAY INTERFACE

CODING A / HOUSING COLOR BLACK

CODING B / HOUSING COLOR GREY

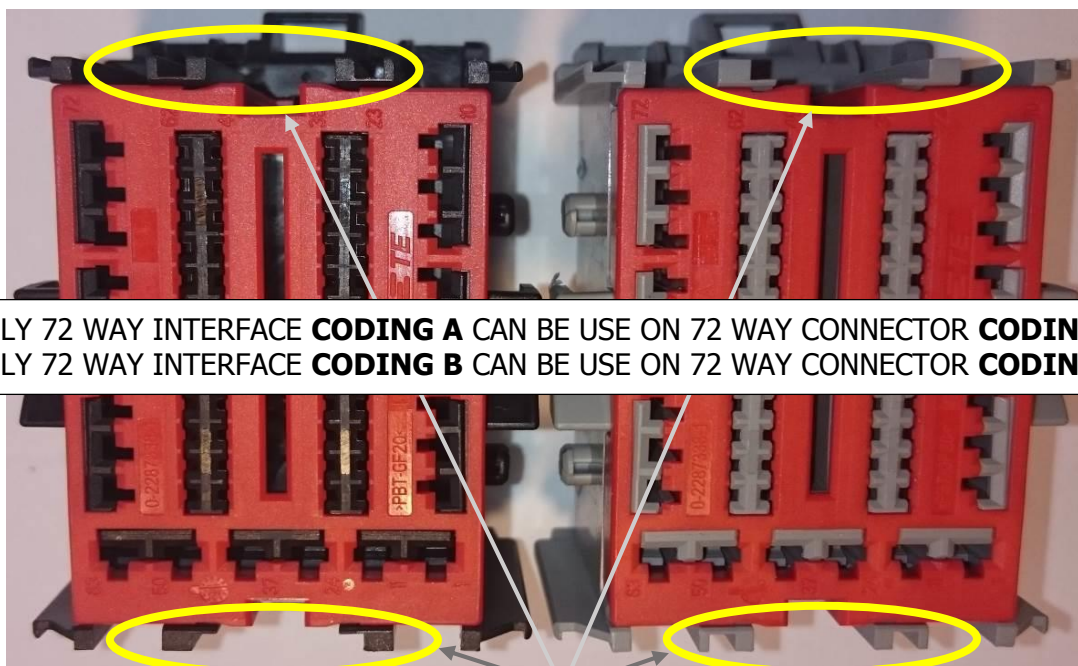

ONLY 72 WAY INTERFACE CODING A CAN BE USE ON 72 WAY CONNECTOR CODING A
ONLY 72 WAY INTERFACE CODING B CAN BE USE ON 72 WAY CONNECTOR CODING B

CONNECTOR HOUSING CODING RIBS

Figure 20: CNNECTOR HOUSING CODING RIBS

Step 2:

Insert connector until lever moves



PUSH TOWARDS INTERFACE

Figure 21: Connector insertion into the interface



IF THE LEVER IS IN PRE-LOCK POSITION AND THE ORIENTATION ON INTERFACE IS CORRECT, THE 72 POS. CONNNECTOR CAN BE MATED. ONLY ONE ORIENTATION CAN BE MOUNTED

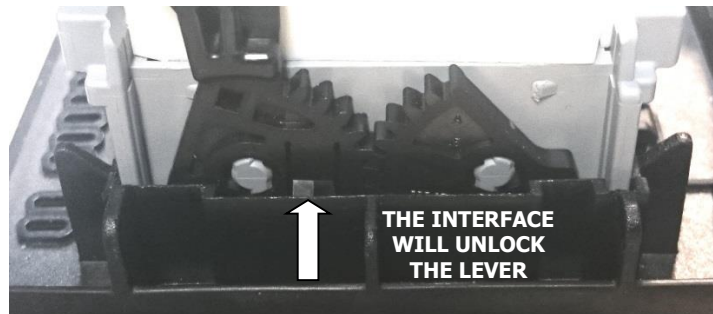

Figure 22: Shows the lever release feature (for information only)

Step 3:

LEVER BECOMES RELEASED (SEE NEXT PAGE)

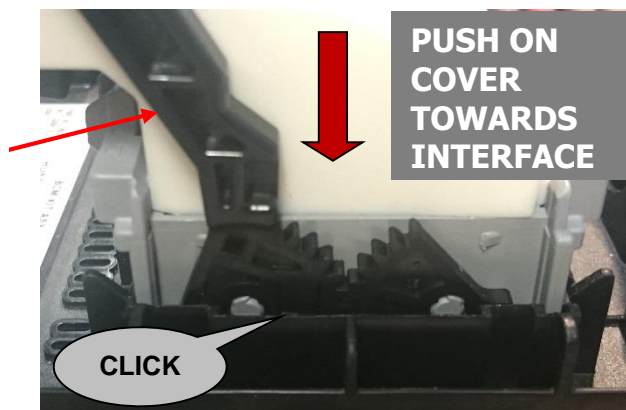
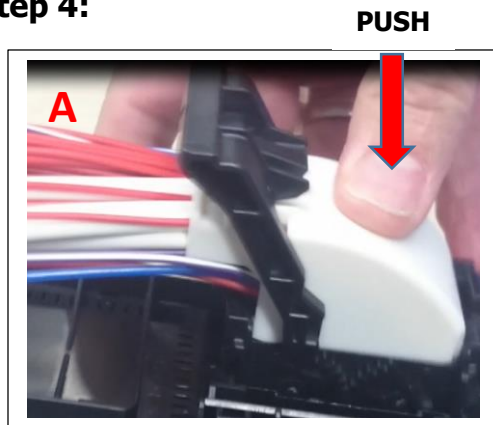

Figure 23: Push onto the wire dress cover

Step 4:



LEVER JUMP

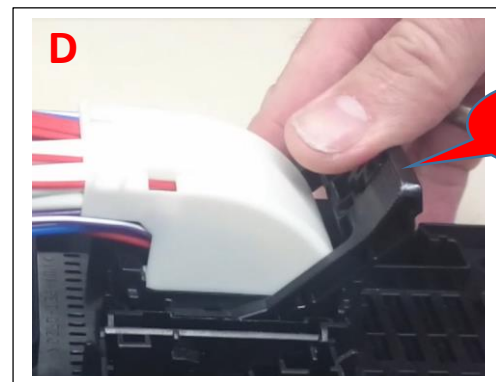
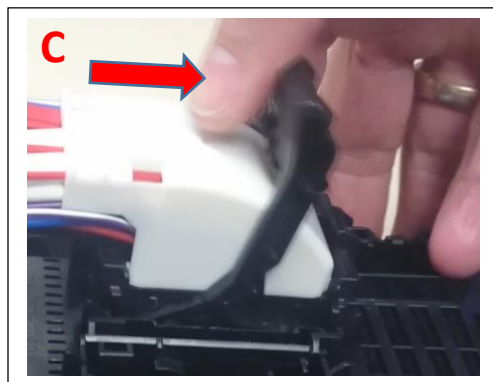
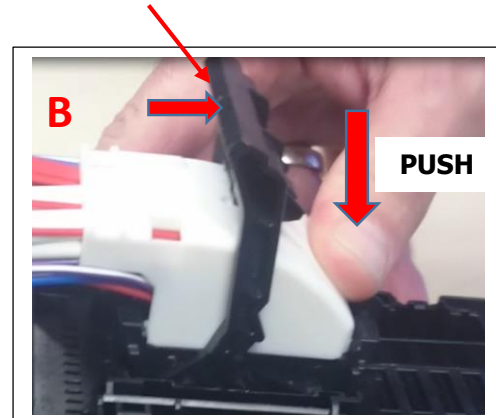
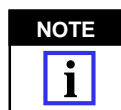

Figure 24: Push onto the wire dress cover until the lever is moved as shown by step B



PUSH THE 72 WAY CONNECTOR AS SHOWN IN FIGURE [Figure 24 B](#). NOW THE LEVER CAN BE MOVED TO THE END-LOCK POSITION AS SHOWN BY FIGURE [Figure 24 D](#).



MAKE SHUR THAT THE LEVER IS LOCKED INTO THE HOUSING PROPERLY.

2.7.2 72 WAY CONNECTOR / INTERFACE UNLOCK AND REMOVAL FROM BACKSIDE

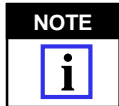

TO REMOVE THE 72 WAY CONNECTOR FROM THE MODULE (INTERFACE) PUSH ON THE MARKED SURFACE SHOWN IN Figure 25

Step 1:

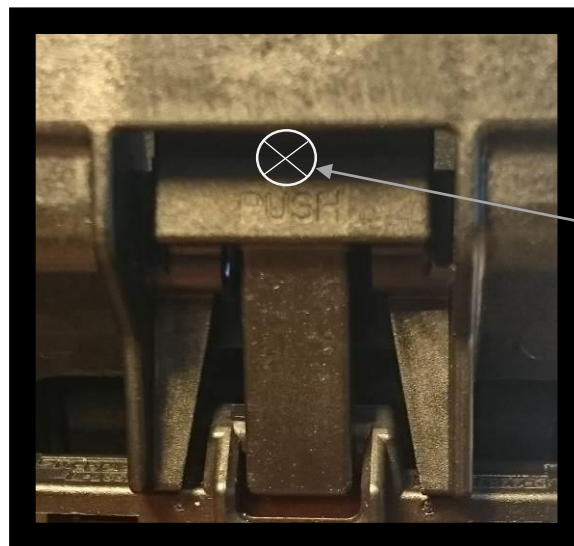

PUSH TO RELEASE THE LEVER/CONNECTOR

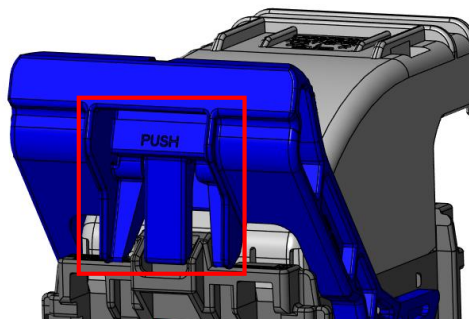
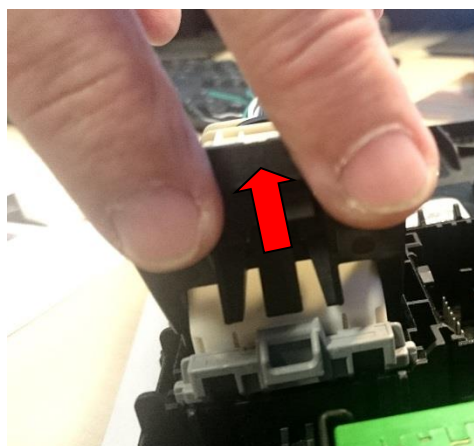

Figure 25: Release area of 72 way connector

Step 2a:

MOVE THE UNLOCKED LEVER TO UNMATE THE CONNECTOR. (SEE NEXT PAGE)



Step 2b:

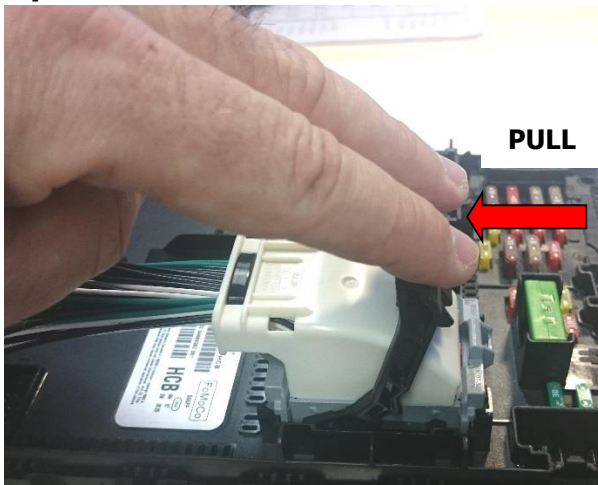

Step 2c:

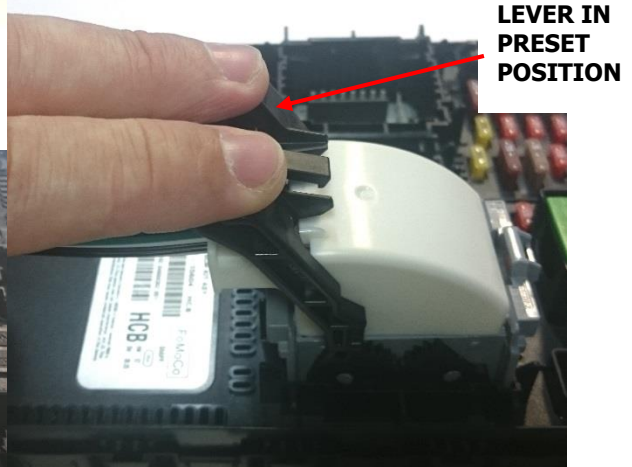
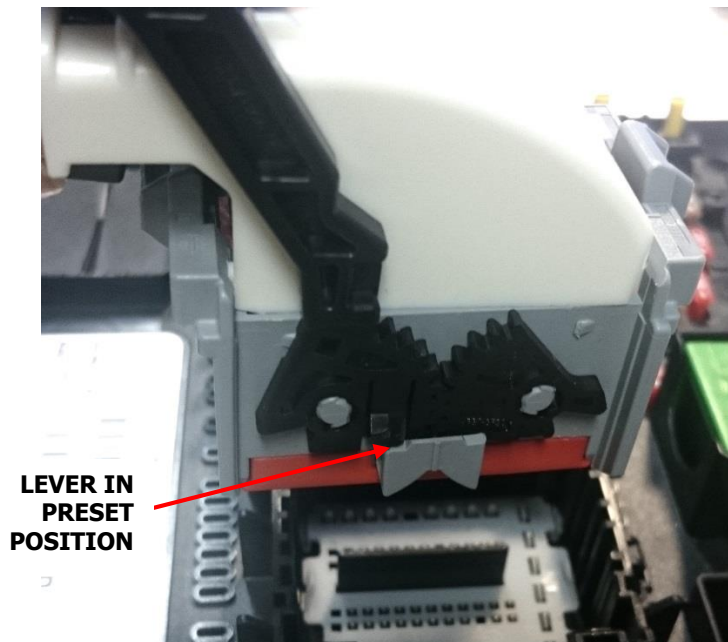

Figure 26: Unmate connector by moving lever back into the pre-lock position

Step 3:



**PULL THE 72 WAY
CONNECTOR
RETURN IN PRESET
POSITION**

Figure 27: Remove connector from BCM module



AFTER STEP 1 & 2 WAS SUCCESSFULLY PERFORMED, YOU CAN REMOVE THE CONNECTOR FROM BCM MODULE

2.7.3 72 WAY CONNECTOR / INTERFACE UNLOCK AND REMOVAL FROM FRONTSIDE WITH SCREWDRIVER

(OPTIONAL)

Step 1:

TO BE DONE ONLY IF
USAGE OF SCREW
DRIVER IS ALLOWED!

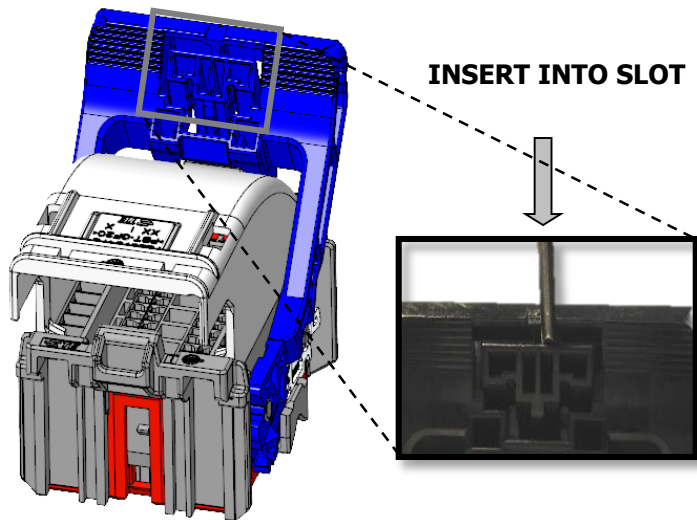

PUSH THE SCREWDRIVER BEHIND THE LEVER RELEASE FEATURE AS SHOWN ABOVE

Step 2:

TURN TO
UNLOCK THE
LEVER RELEAS
FEATURE

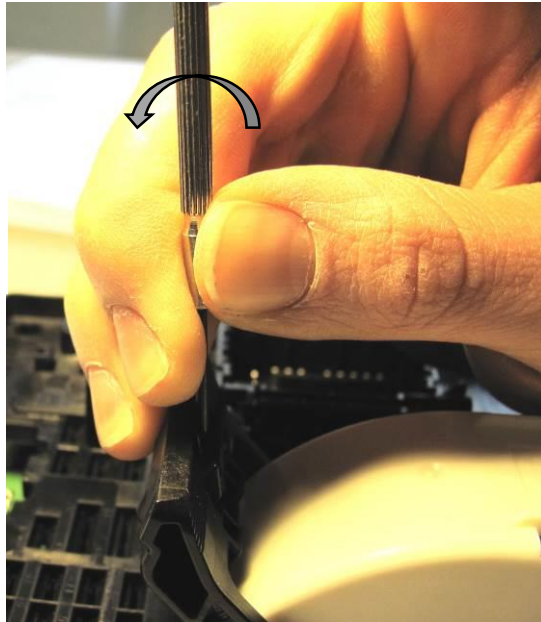

UNLOCK THE LEVER!

Step 3:

**PULL THE
LEVER TO
UNMATE THE
CONNECTOR**



PULL THE LEVER INTO PRE-LOCK POSITION BY HAND AND REMOVE THE CONNECTOR FROM THE BCM MODUL (INTERFACE)