



NOTE

All numerical values are in metric units [with U.S. customary units in brackets]. Dimensions are in millimeters [and inches]. Unless otherwise specified, dimensions have a tolerance of ± 0.13 [$\pm .005$] and angles have a tolerance of $\pm 2^\circ$. Figures and illustrations are for identification only and are not drawn to scale.

1. INTRODUCTION

This specification covers the requirements for application of Micro IDC Terminals. These terminals are insulation piercing and are designed to accept a wire size range of 40 through 30 AWG solid round copper magnet wire with single insulation.

Basic terms and features of this product are provided in Figure 1.

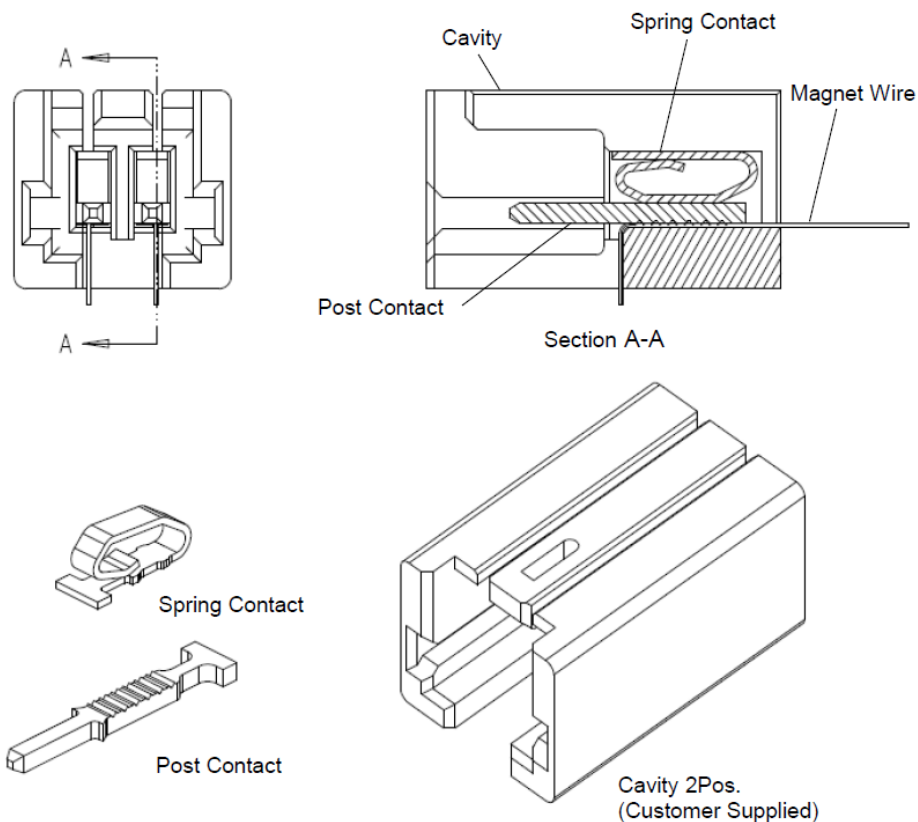

Figure 1

2. REFERENCE MATERIAL

2.1. Revision Summary

This paragraph is reserved for a revision summary of the most recent additions and changes made to this specification which include the following:

- Initial release

2.2. Customer Assistance

Reference Product Base Part Number 2366999 and Product Code 1043 are representative of Nano MAG-MATE Terminals. Use of these numbers will identify the product line and help you to obtain product and tooling information when visiting www.te.com or calling the number at the bottom of page 1.

2.3. Drawings

Customer drawings for product part numbers are available from www.te.com. Information contained in the customer drawing takes priority.

2.4. Specifications

Product Specification [108-140191](#) provides product performance and test results.

2.5. Instructional Material

Instruction sheets (408-series) provide product assembly instructions or tooling setup and operation procedures and customer manuals (409-series) provide machine setup and operating procedures. Instructional material that pertain to this product are:

- [408-3295](#) Preparing Reel of Contacts for Application Tooling
- [408-9816](#) Handling of Reeled Products

3. REQUIREMENTS

3.1. Safety

Do not stack product shipping containers so high that the containers buckle or deform.

3.2. Storage

A. Storage Temperature and Humidity

Products should be stored at room temperature and low ambient humidity. The temperature and humidity should be in the range as per DIN IEC68 (15-35°C, 25-75% relative humidity). Products should not be exposed to extreme temperatures, intense humidity or damaging mediums (acid or base atmospheres, aggressive agents, etc.)

B. Durability of Products

These products have a normally unlimited durability, provided they are stored in their original packing and at normal storage temperature and humidity. Exceptions are solderable products, tubes and cables. Solderable products will be solderable only within 6 months after delivery.

C. Ultraviolet Light

Prolonged exposure to ultraviolet light may deteriorate the chemical composition used in the product material.

D. Shelf Life

The product should remain in the shipping containers until ready for use to prevent deformation to components. The product should be used on a first in, first out basis to avoid storage contamination that could adversely affect performance.

E. Chemical Exposure

Do not store product near any chemical listed below as they may cause stress corrosion cracking in the material.

Alkalies	Ammonia	Citrates	Phosphates	Citrates	Sulfur Compounds
Amines	Carbonates	Nitrites	Sulfur Nitrites		Tartrates



NOTE

Where the above environmental conditions exist, phosphor-bronze contacts are recommended instead of brass if available.

3.3. Cavity Design

Performance of the Nano MAG-MATE is dependent on insertion into a cavity that is designed to TE guidelines. Cavity drawings (411-series) provide cavity dimensions and interface dimensions.

Drawing number	Connector position	Wire size (mm)	Interface
411-106401	2	0.08 ~ 0.15 (single wire only)	Mini CT Connector

Drawings of final design must be supplied to TE Engineering for review and approval and for compatibility of insertion equipment. The following items pertain to all applicable cavity designs.

1. Recommended material is 30% glass filled nylon and PBT or TE Engineering approved equivalent.
2. Coil windings and other assembly components must not extend above the base of the wire slot or obstruct proper seating of the magnet wire in the slot.
3. Draft angles must be held within the feature tolerance.
4. Consideration shall be given for start and finish winding to prevent magnet wire crossover.

3.4. Wire placement

The magnet wire must be placed on the bottom of the cavity slot prior to terminal insertion. The free end shall be laced and wrapped a minimum of three times around the tie-off post. Position of the tie-off post should be designed by customer accordingly as indicated in Figure 2 as a reference.

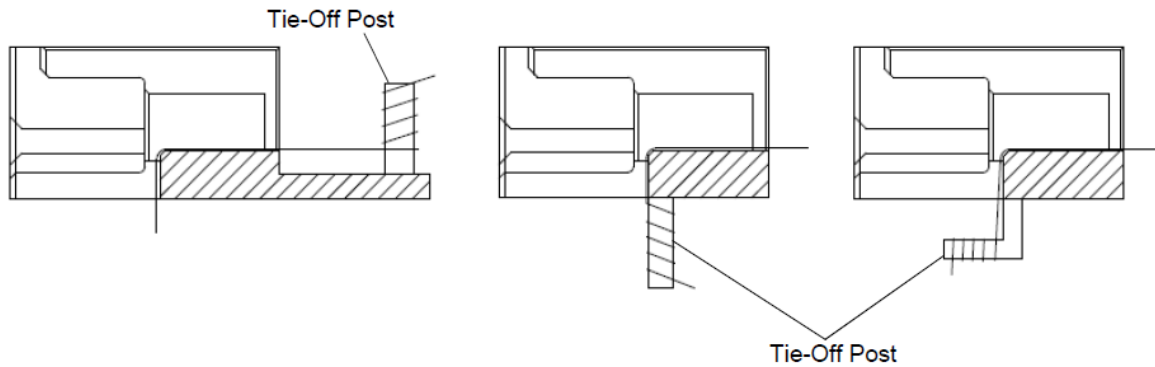

Figure 2



NOTE

- (1) Pre-design consultation with TE Engineering is necessary to be sure the position of the tie-off post for automatic terminal insertion machines.
- (2) Magnet wire must be flat on the bottom of the cavity slot to avoid any damages by serrated burrs of post contact during terminal insertion process as indicated in Figure 3.

Correct

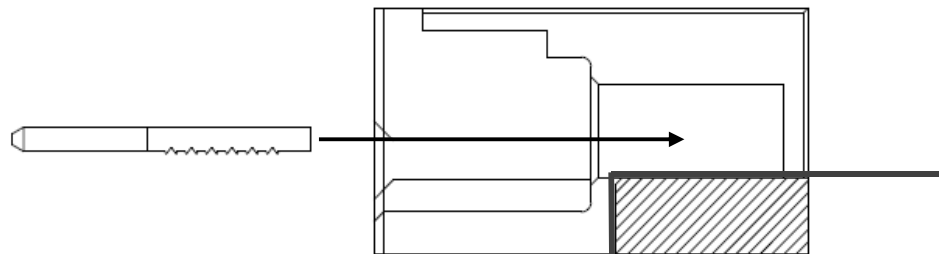

Incorrect

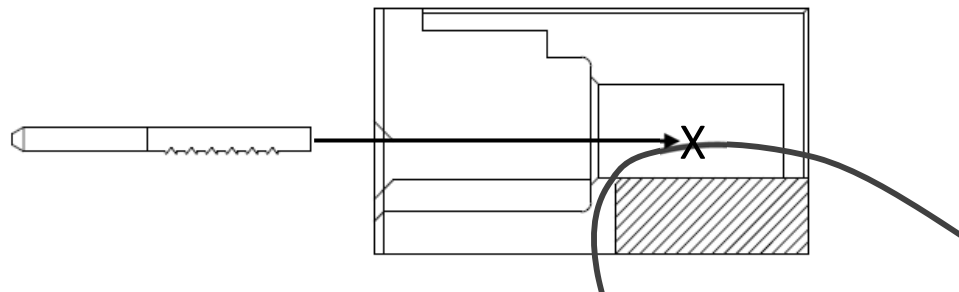

Figure 3

3.5. Terminal Insertion

The terminal shall be inserted in the cavity as shown Figure 4.

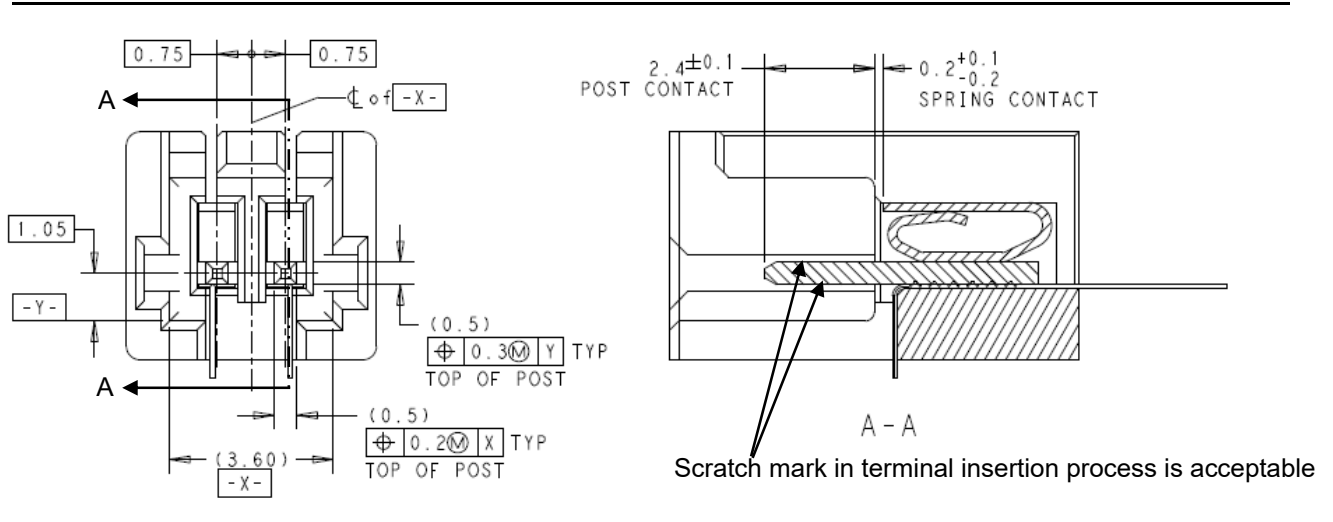

Figure 4

3.6. Magnet Wire Location

The Magnet wire must be placed between cavity and terminal serrations after inserting the terminals into the cavity.

3.7. Terminal Cutoff Tab and Burr

A. Cutoff Tab

The terminal cutoff tab shall be within the limits as specified in Figure 5.

B. Burr

The terminal cutoff tab shall be within the limits as specified in Figure 5.

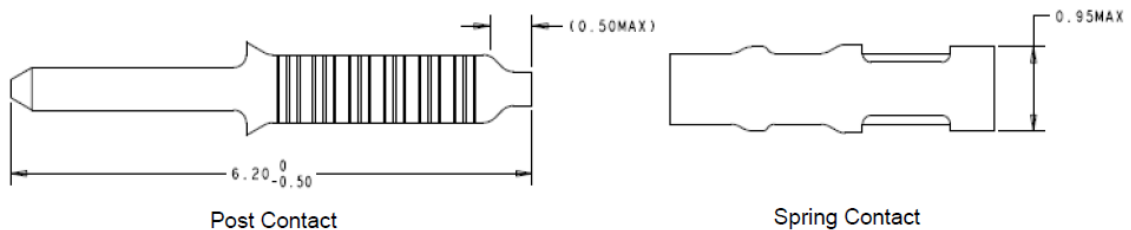

Figure 5

3.8. Repair/Replacement

**CAUTION**

Damaged product should not be used. If a damaged terminal is evident, it should be cut from the wire and replaced with a new one. Terminals should not be re-terminated.

4. QUALIFICATION

Magnet wire terminations using Nano MAG-MATE, cavities, and assembly requirements outlined in this specification will conform to the product specification provided in 108-140191.

5. TOOLING

A variety of insertion tooling are available for your production needs. Some tooling is shown in Figure 6. Contact the Product Information Center number located at the bottom of page 1 for your specific requirements.

**NOTE**

TE Tool Engineers have designed machines for a variety of application requirements. For assistance in setting up prototype and production line equipment, contact TE Tool Engineering through your local TE Representative or call the Product Information Center number at the bottom of page 1.

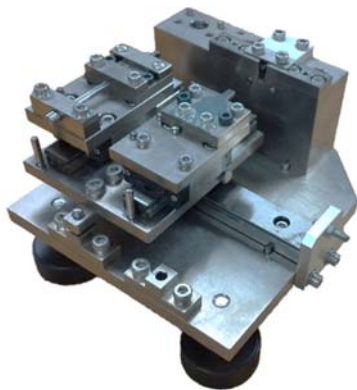

Manual Insertion Tool



Semi-Automation Machine

Figure 6

6. VISUAL AID

The illustration below shows a typical application of this product. This illustration should be used by production personnel to ensure a correctly applied product. Applications which do not appear correct should be inspected using the information in the preceding pages of this specification and in the instructional material shipped with the product or tooling.

HOUSING MUST NOT BE SCRAPED,
CRACKED, BROKEN, OR HAVE ANY
OTHER SIGNS OF DAMAGE

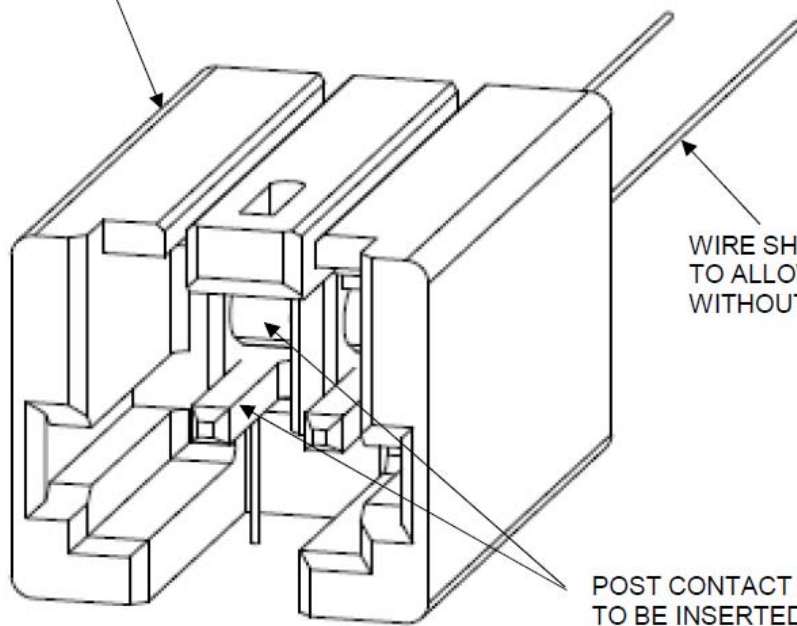

WIRE SHOULD HAVE SUFFICIENT SLACK
TO ALLOW ANY NECESSARY MOVEMENT
WITHOUT STRETCHING THE WIRE

POST CONTACT AND SPRING CONTACT
TO BE INSERTED TO THE PROPER DEPTH
AS SHOWN IN PRECEDING FIGURES

Figure7: Visual Aid