

040 Series Tab Contact

1. Scope:

This specification covers the requirements for crimping 040 series tab contact.

2. Application Contacts:

Contact Features	Contact P/N	Nominal Wire Size	Remarks
.040 Tab contact	1897724-1	0.3 ~ 0.5 (AWG # 22 ~ AWG #20)	

3. Nomenclature

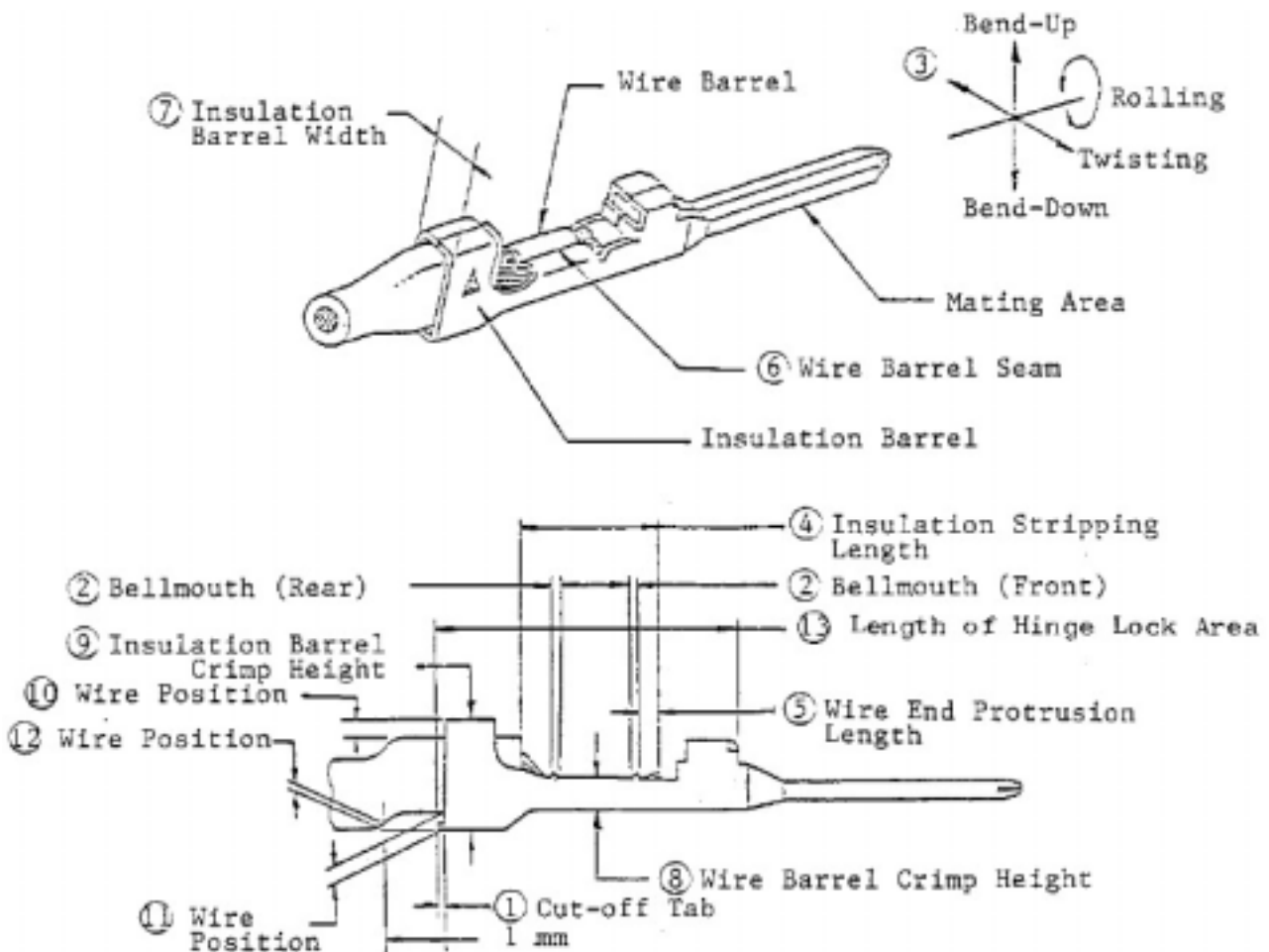

Fig. 1

4. Crimping Condition

No.	Checking Items		Requirements	Remarks
1	Cut-off Tab Length		0.25 mm Max.	Fig. 1
2	Deformation after Crimping	Bend	-4° ~ +2°	Fig. 1
		Twist	± 3° Max.	
		Rolling	± 5° Max.	
3	Bell-mouth	Front	0.4 mm Max.	Fig. 1
		Rear	0.15 ~ 0.65 mm	
4	Wire Insulation Striping Length		4 ~ 4.5 mm Ref.	Fig. 1
5	Wire End Protrusion Length		Wire-end must protrude beyond the front edge of Wire barrel, but shall not exceed 1.5mm	Fig. 1
6	Wire Barrel Seam		Core wire shall not be seen.	Fig. 1
7	Insulation Barrel Width (after crimping)		2.05 mm Max.	Fig. 1
8	Wire Position		-	Fig. 1
9	Length of Hinge Lock Area		10.3 mm Max.	Fig. 1

5. Crimp Data:

Application Crimp:

Contact P/N	Applicator Number	Wire Size (mm ²)	Wire Barrel Crimp		Insulation Barrel Crimp
			Width (mm)	Height (mm)	Width (mm)
1897724-1	T.B.D	0.3	1.57 "F"	0.86 ±0.03	2.03 "F"
		0.5	1.57 "F"	0.97 ±0.03	2.03 "F"

- Note:
1. Crimp Width dimension are not the product width after crimping, but given by the width of crimper slot for reference.
 2. Control the width of wire barrel within 0.2mm after crimp.
 3. Insulation Barrel Crimp Height recommend 2.3 mm.

6. Applicable Wire Data:

Cable Type	Nominal Wire Size	Number of Strands / Diameter of Conductor	Calculated Cross Section Area (mm ²)	Overall Outside Diameter	
				Normal	Maximum
AVSS	0.3	7 / 0.26	0.3717	1.4	1.5
AVSS	0.5	7 / 0.32	0.5630	1.6	1.7

7. Revision History

A	RELEASED	13.OCT.'09
REV.	REVISION RECORD	DATE

8. Specification Approval

Prepared by,

KT JUNG

Product Engineer

Checked By,

JW JUNG

Senior Product Engineer

Approved by,

HG CHO

Product Engineering Manager