

**LUMAWISE LED HOLDER, TYPE LUMIPACK N1**

1. 適用範囲

本取付適用規格は、LUMAWISE LED HOLDER, TYPE LUMIPACK N1の取付け条件およびワイヤ挿入条件について規定する

1. This Application Specification provides for the requirements of mounting and wire installation to LUMAWISE LED HOLDER, TYPE LUMIPACK N1.

2. 適用コネクタ

名称:LUMAWISE LED HOLDER, TYPE LUMIPACK N1

製品型番:2134318-1

2. Applicable connectors

NAME : LUMAWISE LED HOLDER, TYPE LUMIPACK N1

PRODUCT PART NO : 2134318-1

3. 適用電線

LUMAWISE LED HOLDER, TYPE LUMIPACK N1に適用するワイヤをFig.1に示す

3. Applicable wires

The Applicable wires to LUMAWISE LED HOLDER, TYPE LUMIPACK N1 is shown in Fig.1

電線サイズ Wire Range AWG.No	素線数／素線径 Number of Conductors／Diameter of a conductor	絶縁被覆仕上げ径 Insulation Diameter (mm)	備考 Remarks
24	1/0.511	φ1.35 Max	Solid

Fig.1

#### 4. ワイヤストリップ長さ及びワイヤ挿入に関する注意事項

#### 4. Wire strip length and wire insertion instruction

##### 4.1 ワイヤストリップ長さ

ワイヤストリップ長さについてFig.2に示す

##### 4.1 Wire strip length

The wire strip length is shown in Fig.2

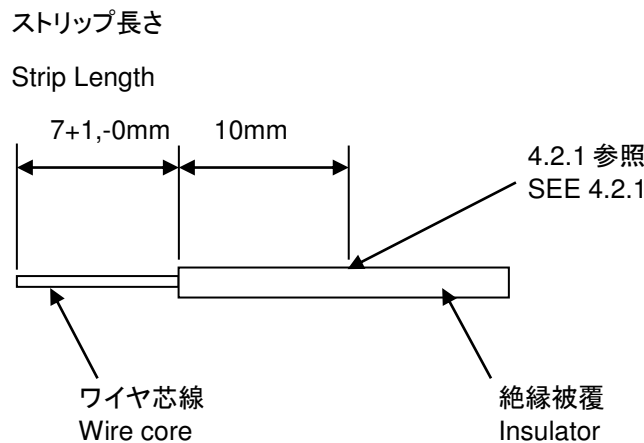

Fig.2

#### 4.2 ワイヤ挿入に関する注意事項

4.2.1 この位置を抑えLUMAWISE LED HOLDER, TYPE LUMIPACK N1に取り付けることを推奨する。

4.2.2 被覆剥ぎの際には、芯線をまっすぐに抑え、傷や欠落を生じないようにすること。

4.2.3 LUMAWISE LED HOLDER, TYPE LUMIPACK N1からワイヤを引抜いた場合、ワイヤ及びLUMAWISE LED HOLDER, TYPE LUMIPACK N1の再使用不可。(リペア不可)

4.2.4 ワイヤの挿入状態はワイヤ確認窓を見て判断すること。(Fig.3参照)

4.2.5 ワイヤ挿入後、ワイヤとコンタクトの接点部に負荷がかかる挙動なきこと。

#### 4.2 Wire insertion instruction

4.2.1 It is recommended to hold this position fit in LUMAWISE LED HOLDER, TYPE LUMIPACK N1.

4.2.2 Wire-end must be neatly stripped without damages, breakage and nick of wire strand.

4.2.3 When the wire is pulled out from LUMAWISE LED HOLDER, TYPE LUMIPACK N1, do not reuse the wire and LUMAWISE LED HOLDER, TYPE LUMIPACK N1 (Must not repair.)

4.2.4 Judge the wire's insertion condition by the check window.(ref Fig.3)

4.2.5 After insert the wire, there is no load between wire and contact's contact point

LUMAWISE LED HOLDER, TYPE LUMIPACK N1

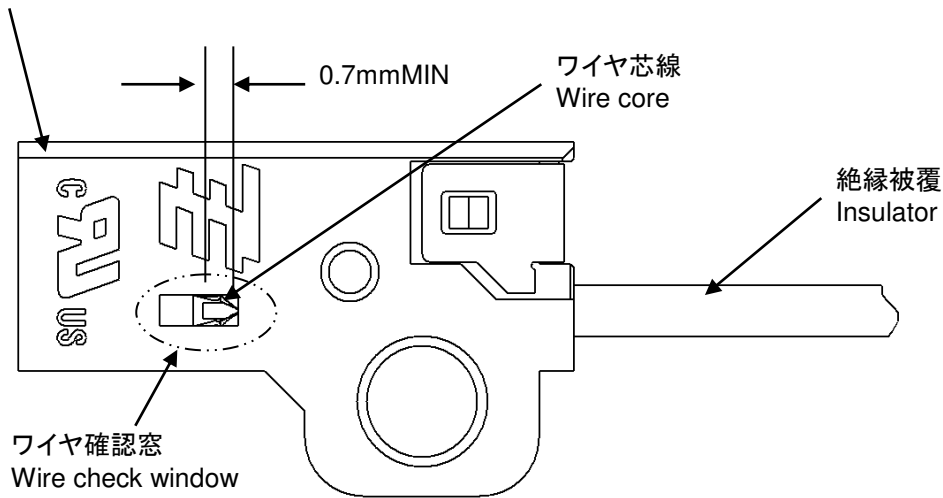

Fig.3

5. LUMAWISE LED HOLDER, TYPE LUMIPACK N1 取付け条件

5. Requirement of mounting to LUMAWISE LED HOLDER, TYPE LUMIPACK N1

5.1 取付けに関する注意事項

5.1.1 適用ねじ: M2.6

5.1.2 ねじ締付けトルク: 18cN·m MAX

5.1.3 一度取外しを行ったLUMAWISE LED HOLDER, TYPE LUMIPACK N1の再使用不可。(リペア不可)

5.1.4 LUMAWISE LED HOLDER, TYPE LUMIPACK N1取付け後、ヒートシンクとLUMAWISE LED HOLDER, TYPE LUMIPACK N1間に浮きがないこと。(Fig.4参照)

5.1 Mounting instruction

5.1.1 Applicable Screw : M2.6

5.1.2 Screw tightening torque : 18cN·m MAX

5.1.3 When LUMAWISE LED HOLDER, TYPE LUMIPACK N1 is detached once, Do not reuse the LUMAWISE LED HOLDER, TYPE LUMIPACK N1. (Must not repair.)

5.1.4 After mounting the LUMAWISE LED HOLDER, TYPE LUMIPACK N1, There must not be floatage between the heat sink and LUMAWISE LED HOLDER, TYPE LUMIPACK N1. (ref Fig.4)

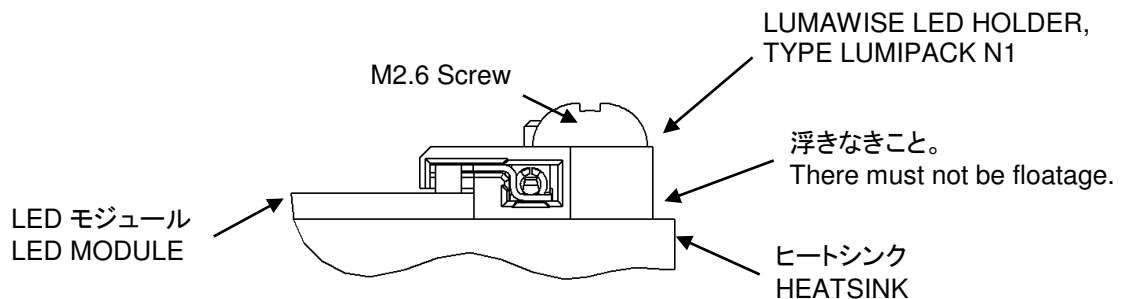

Fig.4