



NOTE

All numerical values are in metric units [with U.S. customary units in brackets]. Dimensions are in millimeters [and inches]. Unless otherwise specified, dimensions have a tolerance of ± 0.13 mm [$\pm .005$ in.] and angles have a tolerance of $\pm 2^\circ$. Figures and illustrations are for identification only and are not drawn to scale.

1. INTRODUCTION

This specification covers the requirements for OPTIMATE Lightplane Connectors designed for mother/daughter board applications. They are available with 2 through 8 contact positions on 12.5 mm [.492 in.] centerline spacing. The connectors are designed with a floating alignment tolerance of 2.16 mm [.085 in.] in line motion and 0.4 mm [.016 in.] circular motion. Motherboard connectors are designed for singlemode and multimode fiber optic cable terminated with SC Singlemode and Multimode Termini. Daughterboard connectors are designed for lightplane singlemode and multimode fiber optic cable terminated with Lightplane Termini.

A motherboard connector consist of a housing with either singlemode or multimode termini plug assemblies, dust covers, and two jackscrew assemblies. A daughterboard connector consists of a housing with numbered cavities for circuit identification, lightplane plug assemblies that thread into the housing, dust covers and mounting hardware consisting of a shoulder screw and nut that provides a floating tolerance for mating connectors. See Figure 1.

When corresponding with TE Connectivity Personnel, use the terminology provided in this specification to facilitate your inquiries for information. Basic terms and features of this product are provided in Figure 1.

Lightplane Motherboard Connector Components

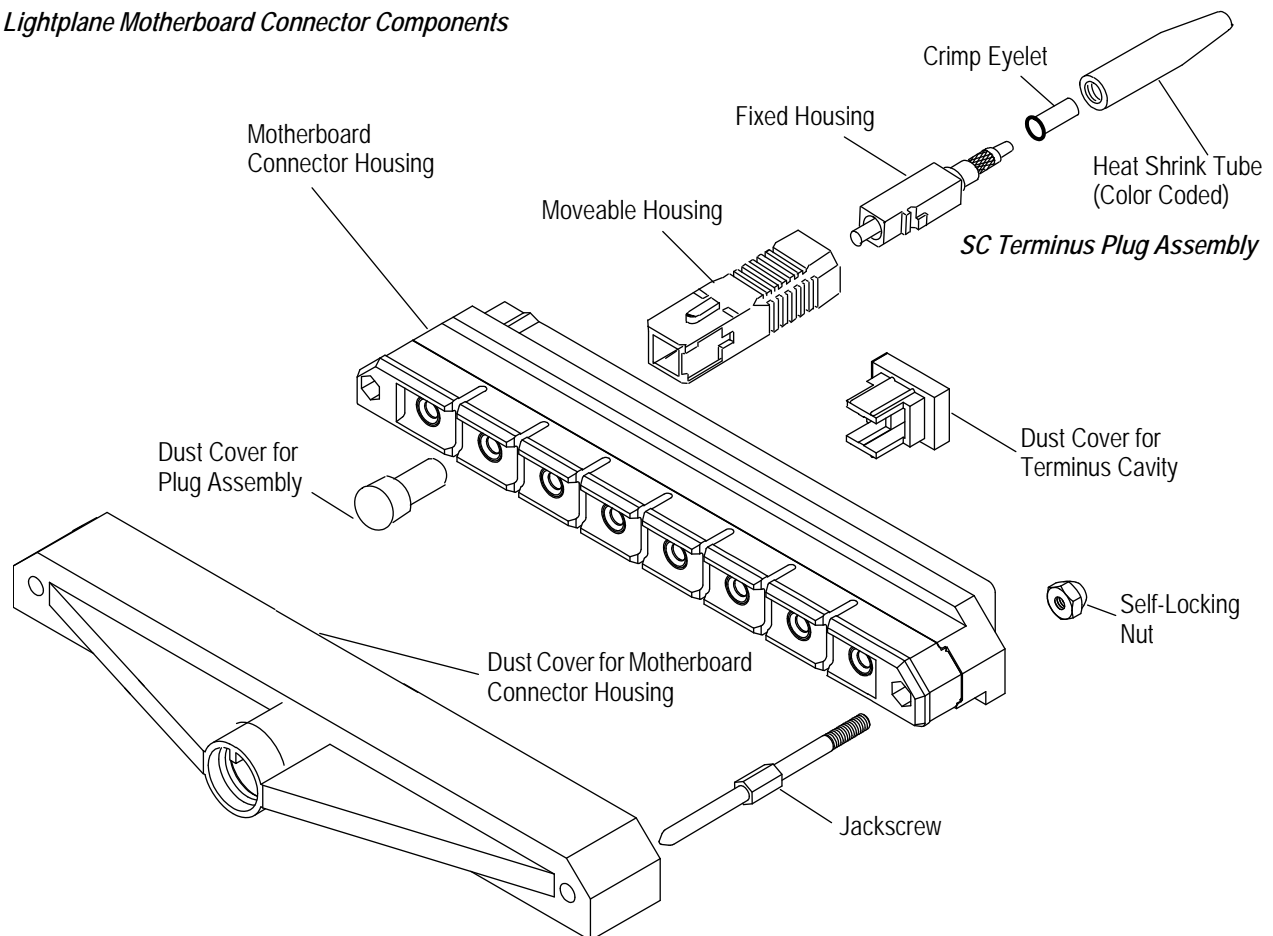

Figure 1 (Cont'd)

Lightplane Daughterboard Connector Components

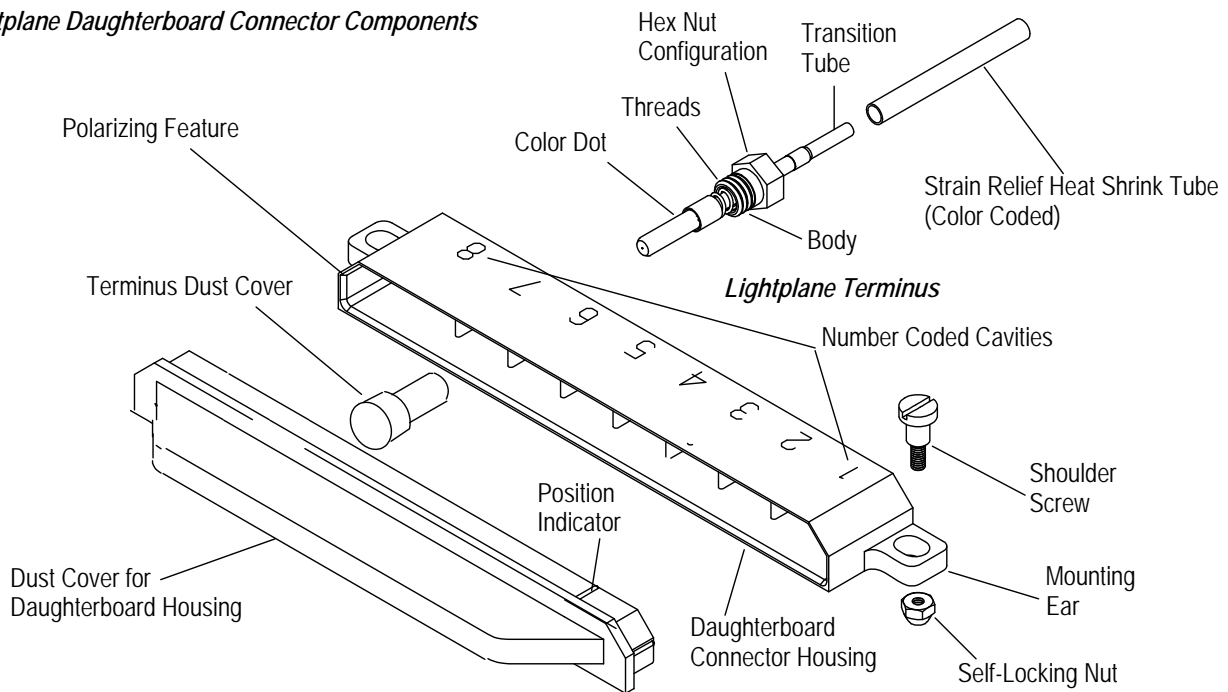

Figure 1 (End)

2. REFERENCE MATERIAL

2.1. Revision Summary

Revisions to this application specification include:

- Updated document to corporate requirements
- Changed text in Paragraph 2.2

2.2. Customer Assistance

Reference Product Base Part Number 503185 and Product Code 1805 are representative of OPTIMATE Lightplane Connectors for motherboard/daughtercard applications. Use of these numbers will identify the product line and help you to obtain product and tooling information. Such information can be obtained through a local Representative, by visiting our website at www.te.com, or by calling PRODUCT INFORMATION or the TOOLING ASSISTANCE CENTER at the numbers at the bottom of page 1.

2.3. Drawings

Customer Drawings for specific products are available from the service network. The information contained in Customer Drawings takes priority if there is a conflict with this specification or with any technical documentation supplied by TE.

2.4. Instructional Material

The following list includes available instruction sheets (408-series) that provide assembly procedures for product assembly, and operation, maintenance and repair of tooling.

<u>Document No.</u>	<u>Document Title</u>
408-4293	Scribe Tool
408-9047	Crimping Tool Dies
408-9394	Lightplane Termini Stripping Tool
408-9460	Curing Oven
408-9485	SC singlemode and multimode Termini Stripping Tools
408-9671	PRO-CRIMPER* Crimping Tool with Dies

3. REQUIREMENTS

3.1. Safety Precautions

**DANGER**

Glass fiber can easily penetrate the skin and eyes. Always use extreme care and wear eye protection when stripping, cutting, and preparing the cable for use. Never look into the end of the fiber when optical power is applied as infrared light can not be seen but it can severely damage the eyes. Also, never eat, drink, or smoke when working with the fibers. This could lead to injection of glass particles.

3.2. Storage

A. Ultraviolet Light

Prolonged exposure to ultraviolet light could cause deterioration of the connector housing material.

B. Shelf Life

The connectors and components should remain in the shipping containers until ready for use and they should be used on a first in, first out basis.

C. Chemical Exposure

Do not store connector components near any chemical listed below as they may cause discoloration and stress to the housing and terminus.

Alkalies	Ammonia	Citrates	Phosphates	Citrates	Sulfur Compounds
Amines	Carbonates	Nitrites	Sulfur Nitrites		Tartrates

D. Temperature Exposure

The lightplane connectors storage and operating temperature range is -40° to 85°C [-40° to 185°F].

3.3. Special Characteristics

A. Motherboard Housing

Motherboard housings are polarized by two beveled edges that prevent mismatching with the daughterboard. The housings have two mounting holes for jackscrews which are used to secure the housing to a panel and provide guide pins that facilitate mating with the daughterboard. Each terminus cavity has a polarizing slot and a tapered lead in that guides the SC Terminus into a fixed position and ensures alignment with the mating Lightplane Terminus.

B. Daughterboard Housing

Daughterboard housings have a polarized pin hood that provides protect for the protruding pin termini. They feature number codes and threads for each cavity. The mounting ears are secured to the daughterboard with standoff screws that provide floating alignment and allow blind mating of connectors.

C. Dust Covers

There are dust covers for the mating faces of the housings, terminus entry cavities in the back of the motherboard, and for individual termini. They should be used to protect the polished cable ends when terminus or connector is not in use.

D. Terminus

The termini are spring loaded to ensure contact pressure is equally applied to each terminus when the connectors are fully mated. The motherboard termini are designed for individual insertion and extraction and are protected by a fixed housing and a polarized movable housing. The daughterboard termini are terminated with cable and threaded into the cavity for a more permanent position. Each daughterboard terminus has a color code dot on the terminus body sleeve that indicates the hole size in the terminus for single mode applications (yellow 125 mm, red 126 mm, and blue 127 mm). See color dot in Figure 5.

E. Assembly Instruments

Professional installer's kits have been assembled to ensure quality applications of each terminus used in the lightplane connectors. See Section 5.

i **NOTE**
Various tool kits are available to meet specific application requirements. One kit includes all of the components needed by a first time user to prepare and inspect a terminus. Some of the components in these kits would not need to be replaced while others would require replacement. All tooling referenced in Section 3, REQUIREMENTS are included by name and number in Section 5, TOOLING.

3.4. Cable Selection and Preparation

A. Type

There are SC singlemode and multimode, and lightplane singlemode and multimode termini for 125- μ m, 126- μ m, and 127- μ m glass fiber optic cable.

B. Preparation

! **DANGER**
Always wear safety glasses when working with optical fibers and immediately dispose of cutoff ends as they can easily cause penetrate the skin and eyes.

Cable for SC Termini must have the cable jacket and buffer stripped and the strength member cut to length. Cable for Lightplane Termini must have the buffer stripped to length. See Figure 2.

i **NOTE**
The recommended stripping tools and applicable instruction material for each are shown in Section 5 of this document.

NOTE: Not to Scale

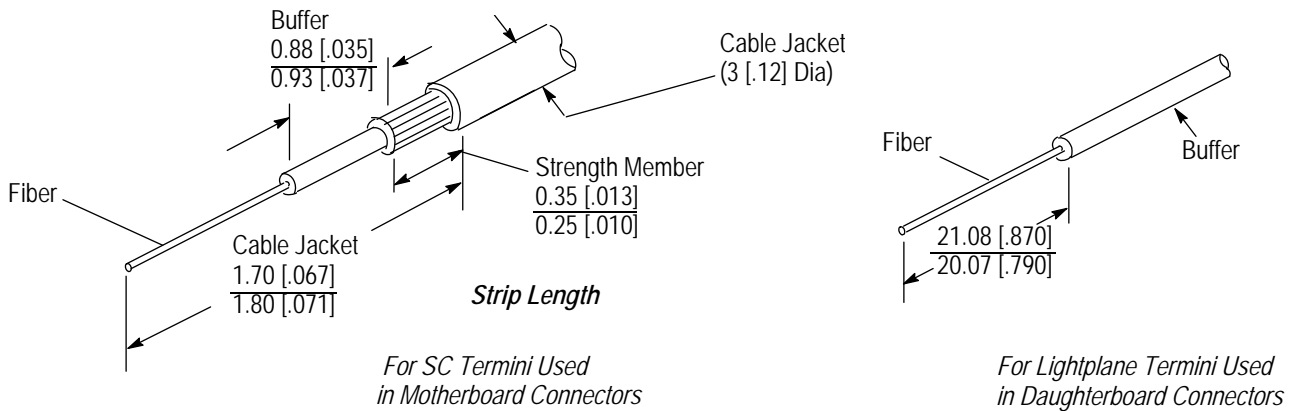

Figure 2

! **CAUTION**
Care must be taken to avoid nicking, scraping, or cutting of the glass fiber during the stripping operation.

3.5. Epoxy

There are different epoxies recommended with curing times of 30 minutes, 2 hours, and 24 hours, depending on your application requirements. The faster curing epoxy is supplied in two separate tubes to be mixed in smaller quantities while the slower curing drying epoxy is supplied in two connected packets of pre-measured resin and hardener. See Figure 3.

EPOXY		CURING		PACKAGES
RESIN	HARDENER	TIME	TEMPERATURE	
502418-1	501202-1	30 Minutes	100°C [212°F]	2 Separate Tubes
501195-4		2 Hours	65°C [150°F]	2 Connected Packets of Pre-Measured Resin and Hardener
		24 Hours	25°C [72°F]	

Figure 3

3.6. Terminus Assembly Requirements

A. SC Terminus (Figure 4)

The following conditions must be met to ensure a good termination.

1. The strain relief tubing and crimp eyelet must be slid over the outer insulation before stripping the cable to avoid damage to exposed cable components.
2. The cable jacket and buffer must be stripped, and the strength member must be cut to length.
3. The size of the stripped cable must be checked by inserting it into the terminus body to be sure the correct fiber and terminus has been selected and that the fiber protrudes beyond the terminus end.
4. An epoxy suitable to time allocation must be selected (see Figure 3).
5. The epoxy must be thoroughly mixed, then placed in a syringe type applicator and all air pockets removed by depressing the plunger with the tip pointed up.



CAUTION

The terminus body must be filled with epoxy to the point where it will accept the fiber optic without overflowing of the epoxy onto the outside of the terminus.

6. The terminus body must be filled by placing the syringe tip in the terminus body until bottomed and depressing the plunger until a small amount of epoxy appears, then the tip must be pulled out slightly and a small amount of epoxy dispersed without allowing overflow onto the outside of the terminus. The tip must be removed quickly to avoid spillage on the outside of the terminus.
7. The inner tube must be cut flush with the rear of the knurled support by pressing the terminus end against a soft protective surface and trimming the inner tube evenly with a sharp knife.
8. The optic fiber of the cable must be inserted into the terminus body until the fiber protrudes slightly from the terminus end and the buffer is bottomed in the terminus.
9. The eyelet must be positioned over the cable strength members until it bottoms on the shoulder, then crimped according to the instructions packaged with the tool (see Section 5).
10. The plug assembly must be inserted into a fiber protector and placed in a vertical position with the terminus end downward until the epoxy cures.
11. After the epoxy has cured, the plug assembly must be removed from the fiber protector and inserted into a movable housing until the latch engages the latch slot.

SC Terminus for Motherboard Application

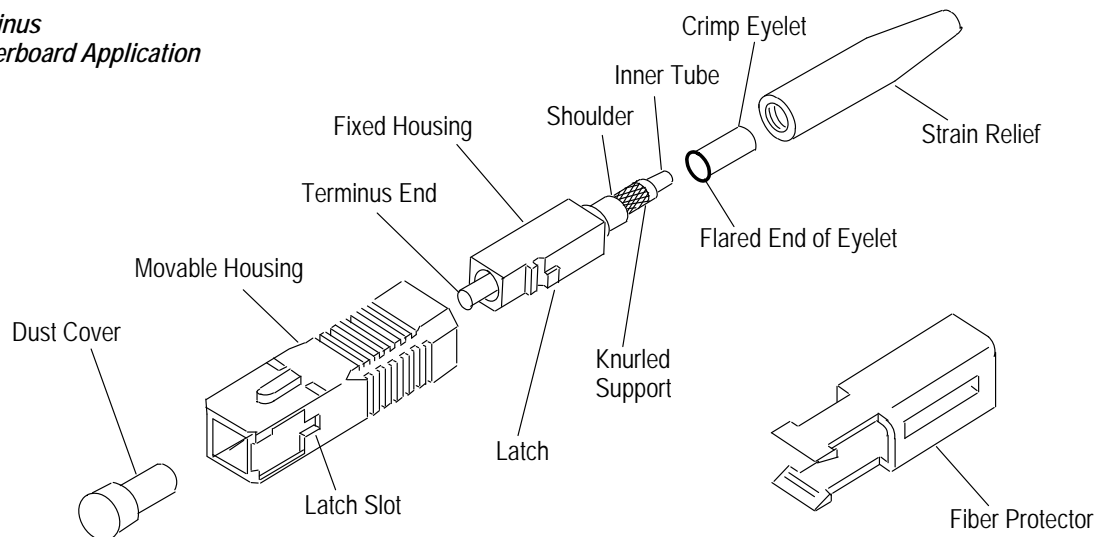

Figure 4

B. Lightplane Terminus (Figure 5)

The following conditions must be met to ensure a good termination.

NOTE

An optional heat shrink tube can be used to provide additional strain relief between the terminus and cable. If used, it must be placed on the cable before stripping the cable.

1. The cable jacket must be stripped to the length specified in Figure 2.
2. The size of the stripped cable must be checked by inserting it into the terminus body to be sure the right fiber and terminus has been selected and that the fiber protrudes beyond the terminus end.
3. An epoxy suitable to time allocation must be selected (see Figure 3).
4. The epoxy must be thoroughly mixed, then placed in a syringe type applicator and all air pockets removed.

CAUTION

When injecting epoxy into the terminus body, care must be used to prevent overflowing on the outside of the terminus.

5. The terminus must be filled with epoxy by placing the syringe tip into the cable entry end until bottomed, depressing the plunger until a small amount of epoxy appears at the tip, then pulling the syringe out slightly to disperse another small amount of epoxy without overflowing onto the outside of the terminus. The syringe must be removed quickly to avoid spillage on the outside of the terminus.

Lightplane Terminus for Daughterboard Application

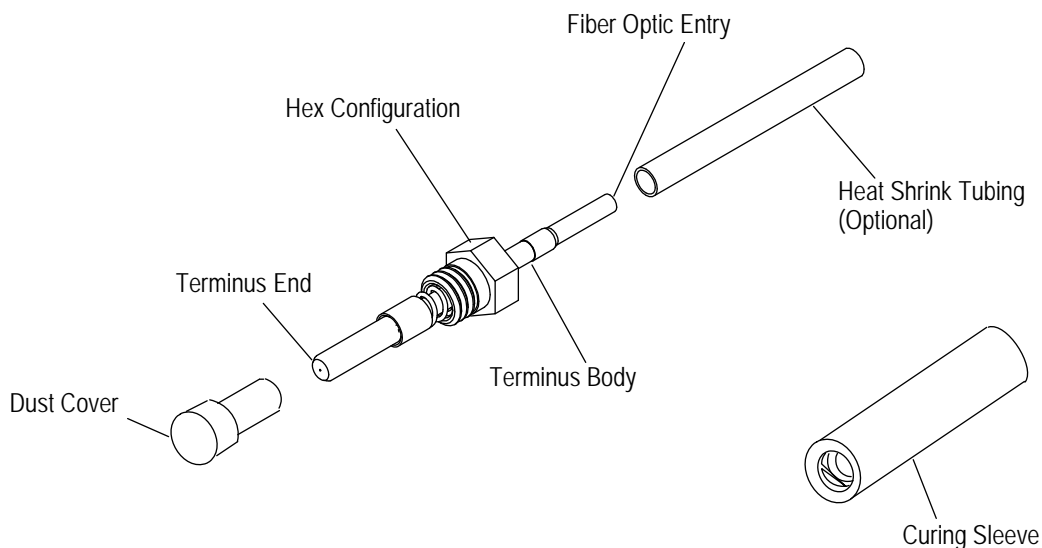

Figure 5

6. The terminus must be inserted into a curing sleeve to protect the fiber end.
7. The optic fiber of the cable must be inserted into the terminus body until bottomed then placed in a stationary vertical position with the end downward until the epoxy has cured in accordance with specific time and temperature requirements (see Figure 3).

NOTE

If the optional heat shrink tubing was used, it must be slid over the support barrel against the hex configuration and heat applied to shrink the tube and to provide strain relief for the cable.

3.7. Polishing Fiber

After the epoxy has fully cured, the protective cap must be removed and the extended tip of the fiber cut off. The remainder must be polished to a high luster finish according to the following requirements.

DANGER

Safely dispose of excess fiber.

CAUTION

Do not allow the scribe tool to come in contact with the epoxy as it could damage the sapphire tip of the tool.

1. The terminus must be held firmly in a stabilized position and the extended end of the fiber just above the hardened epoxy must be marked with a scribe tool. See Figure 6.
2. All sharp edges of the fiber must be removed by holding the terminus in one hand and using a piece of 5- μm polishing film in the other to stroke the fiber lightly.
3. A polishing bushing must be placed on the terminus to serve as a visual gauge and bottoming surface during the polishing process.

Direction of Axial Tension

Figure 6

4. A polishing pad and a polishing plate must be used to support polishing films during polishing of the terminus end. When polishing, the terminus must be moved in a figure-8 pattern to ensure that the full circumference of the optic fiber is even polished. See Figure 7.

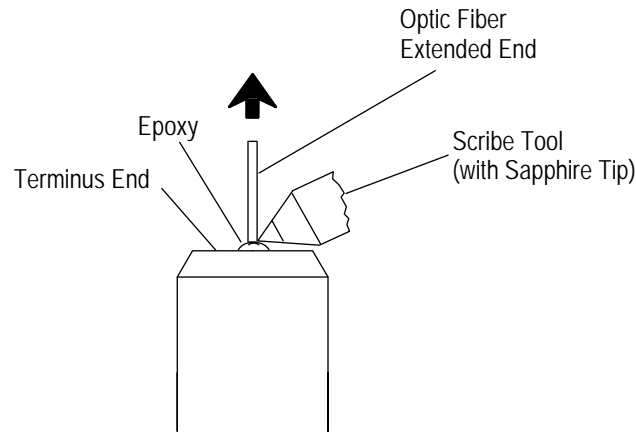
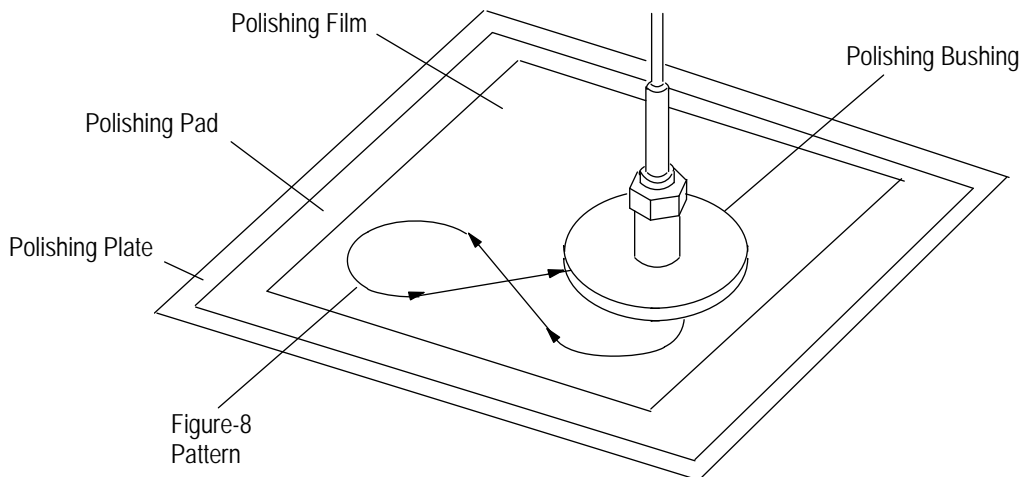

Figure 7

5. The first phase of polishing the terminus end must be done with a 5- μm film using the figure-8 motion and polishing until the epoxy lightens in color and only a small amount of epoxy is apparent on the terminus tip. Next it must be polished with a 3- μm film until all epoxy is gone from the terminus end.

6. The terminus end and polishing bushing must be cleaned with an alcohol-soaked cotton swab or alcohol pad and dried. See Figure 8.

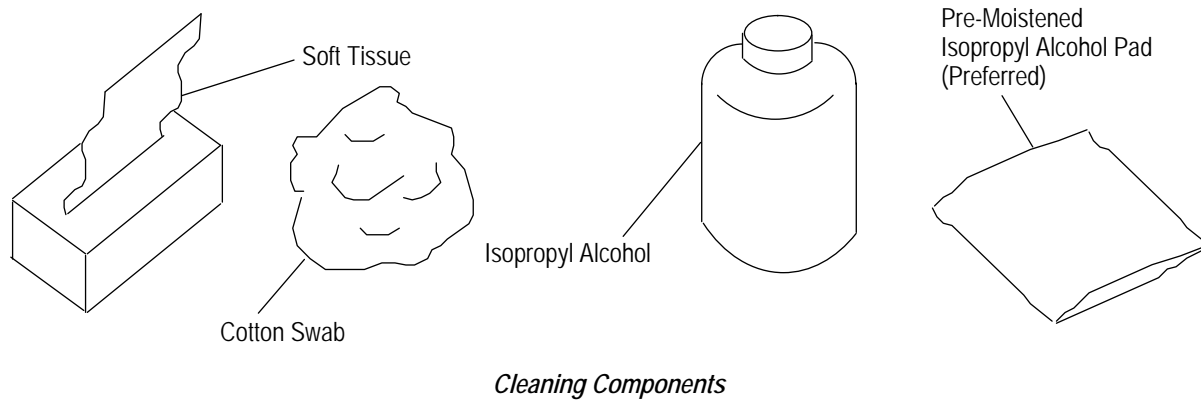

Figure 8

7. The second phase of polishing must be done with 3- μ m using the figure-8 motion and polishing film until all epoxy is gone from the terminus end.



NOTE

The terminus end must be checked frequently during the 3- μ m film polishing process to be sure polishing is stopped as soon as all epoxy is gone.

8. The terminus end and polishing bushing must be cleaned with an alcohol-soaked cotton swab or alcohol pad and dried.

9. The third and final polishing must be done with AF5D Polish Film. Placing a few drops of water on an unused area of the film and polish the terminus end using a circular motion approximately 20 mm [.750 in.] in diameter for 25 seconds.

10. Remove the polishing bushing and clean the terminus with an alcohol-soaked cotton swab or alcohol pad and dried.



CAUTION

A protective cap must be placed on the dried terminus end until the terminus is ready for use or inspection.

3.8. Inspecting Polished Terminus

The terminus must be inspected with the naked eye, then with a microscope to be sure the terminus is free of imperfections.



DANGER

Never inspect or look into the end of an optic fiber when power is applied to the fiber as the infrared light used is invisible but could cause eye injury.

1. The terminus must be checked for loose particles before the protective cap is removed. If any are present or suspect, clean the terminus with an alcohol-soaked cotton swab or alcohol pad, then remove the protective cap and clean the terminus end.

2. An inspection must be made for signs of epoxy. If epoxy is apparent, more polishing on the AF5D Film and addition cleaning will be required until all visible epoxy residue is gone.

3. The optic fiber must be checked with a microscope (see Section 5) for scratches and chips.

4. Large scratches and chips are unacceptable. Large scratches indicate that too much pressure was applied on the 5- μ m film or over polishing was done on the 3- μ m film. Additional polishing will be required or, if the terminus end is too short for the polishing bushing, re-termination will be required. Large chips in the center of the fiber will require re termination of the fiber.

5. Small scratches and small chips on the outer rim are acceptable. See Figure 9.

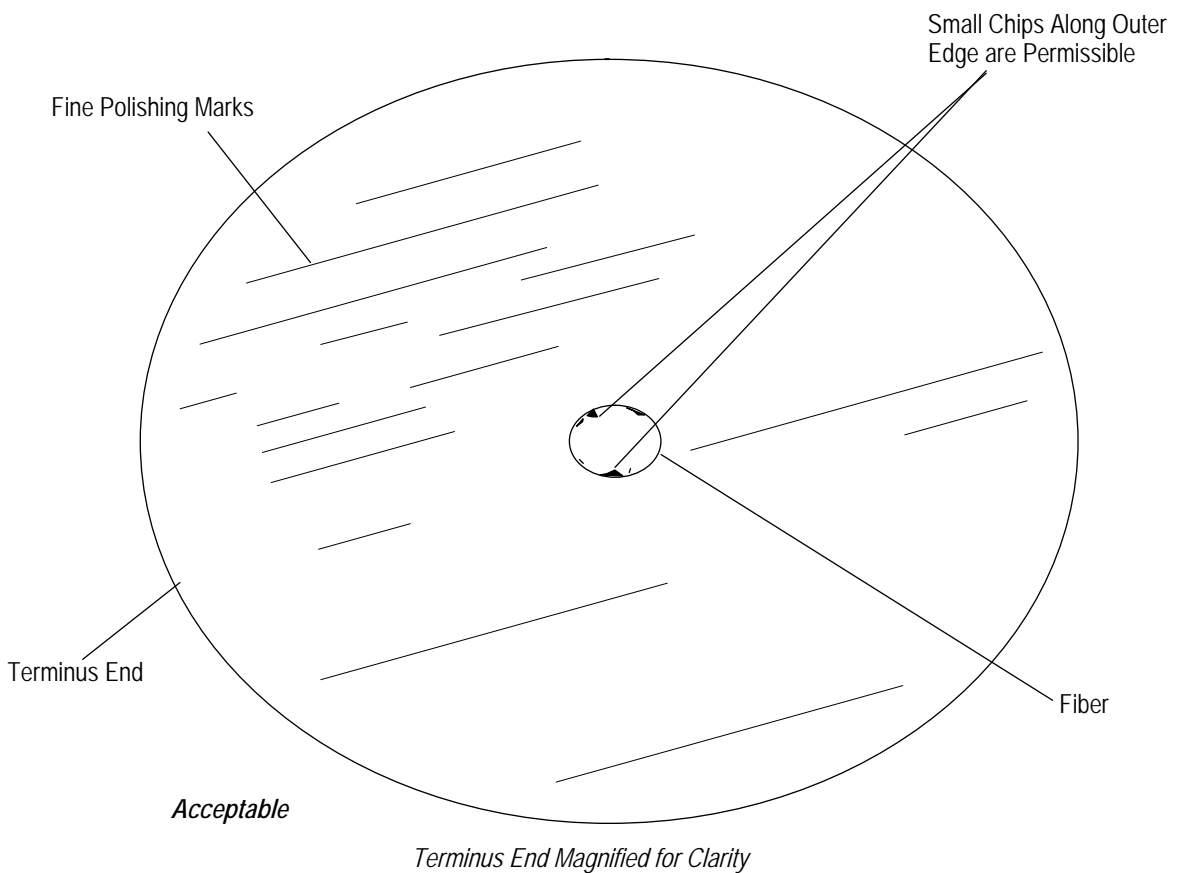
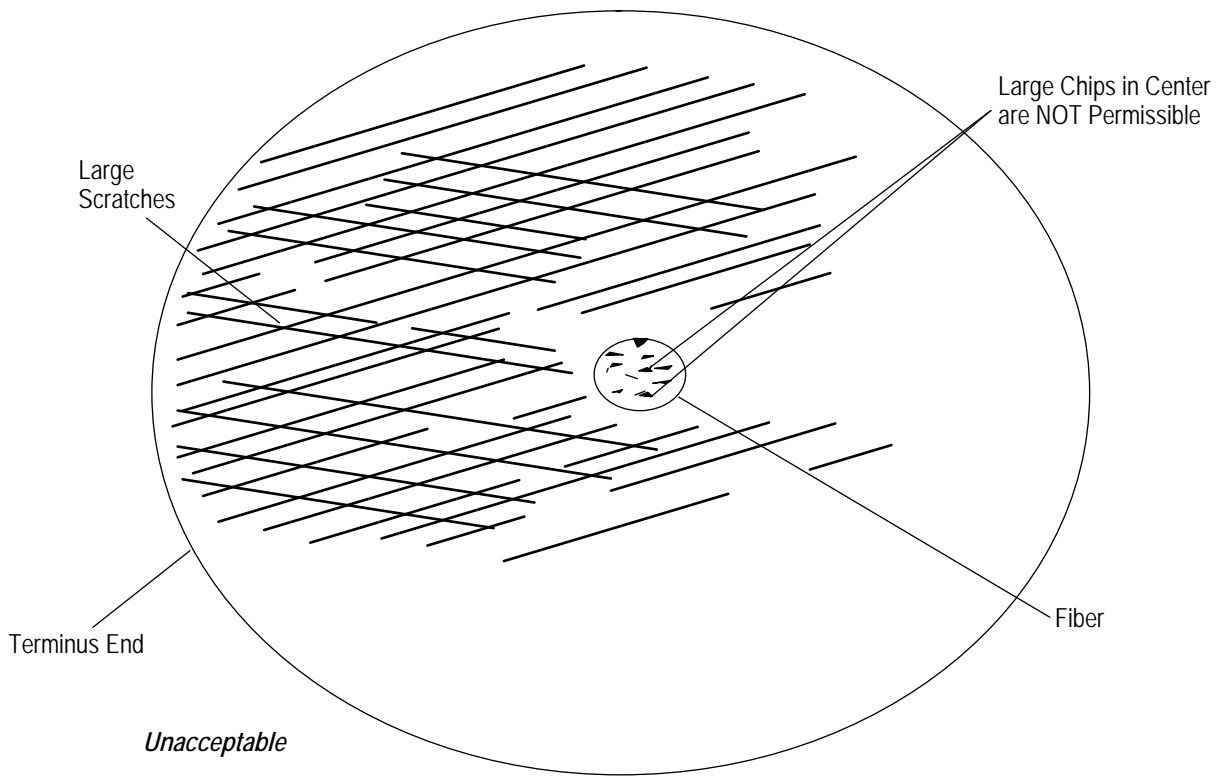

Figure 9

3.9. PC Board Daughterboard Connector

A. Material and Thickness

The pc board material shall be glass epoxy (FR-4, G-10). The connectors have been designed to accommodate a pc board thickness range of 1.40-1.75 mm [.055-.069 in.]. Contact the Product Information Center or the Tooling Assistance Center at the number listed at the bottom of page 1 for suitability of other board materials and thicknesses.

B. Tolerance

The maximum bow of the pc board shall be 0.03 mm [.001 in.] over the length of the connector.

C. Mating Dimension

To ensure proper contact between mating fiber optics, the distance from the back of the guide post holes to the front of the panel must be within the limits specified in Figure 10.

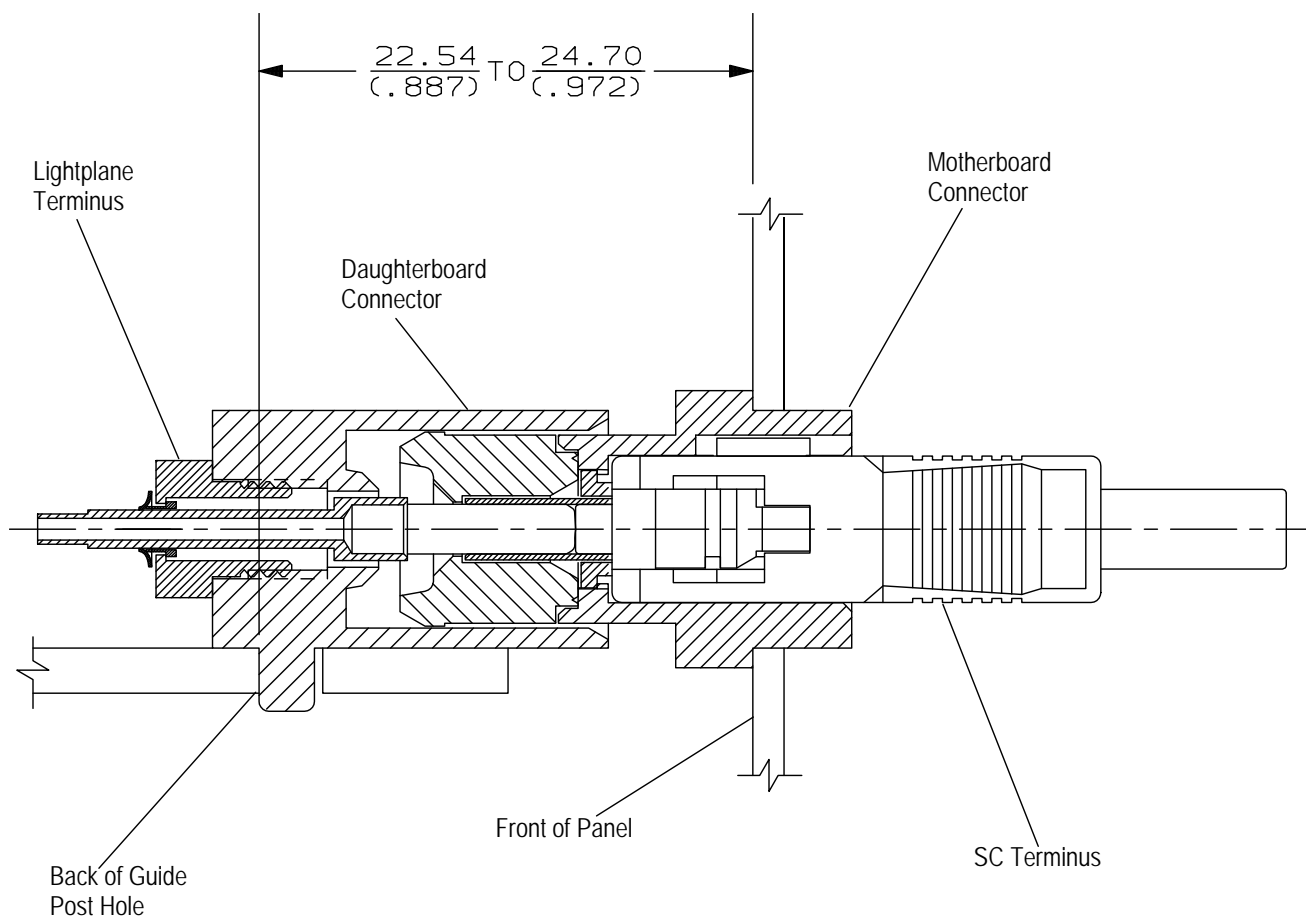
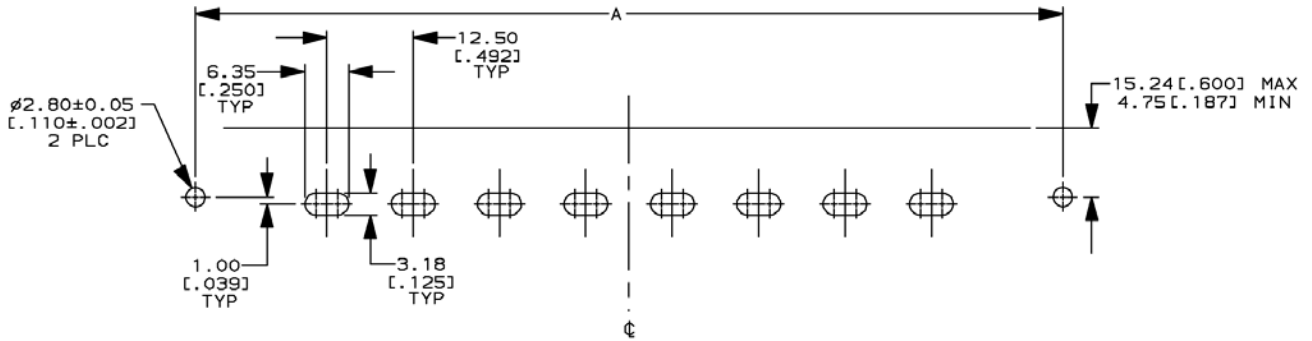

Figure 10

D. Layout

There are precision mounting hole requirements. The guide post holes have clearance dimension that allows the connector floating action that facilitates mating of connectors. The pc board layout for the mounting holes and guide post holes is provided in Figure 11.

Daughterboard PC Board Layout



POS.	A ± 0.12 [.005]
8	125.50 [4.941]
4	75.50 [2.972]
2	50.50 [1.988]
1	38.00 [1.496]

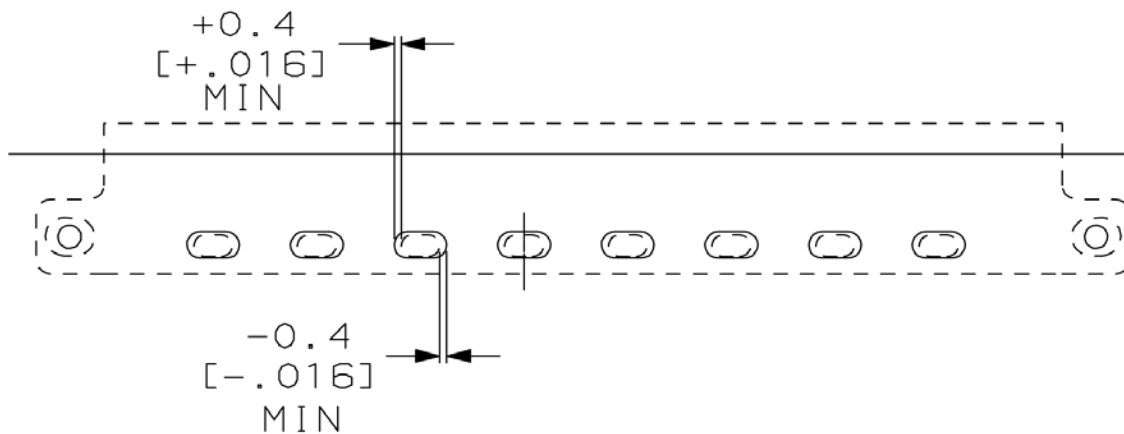

Clearance Requirement for Guide Posts

Figure 11

3.10. Panel Cutout

A cutout must be made in the panel to accommodate the motherboard connector. A panel cutout for the various sizes of connectors is provided in Figure 12.

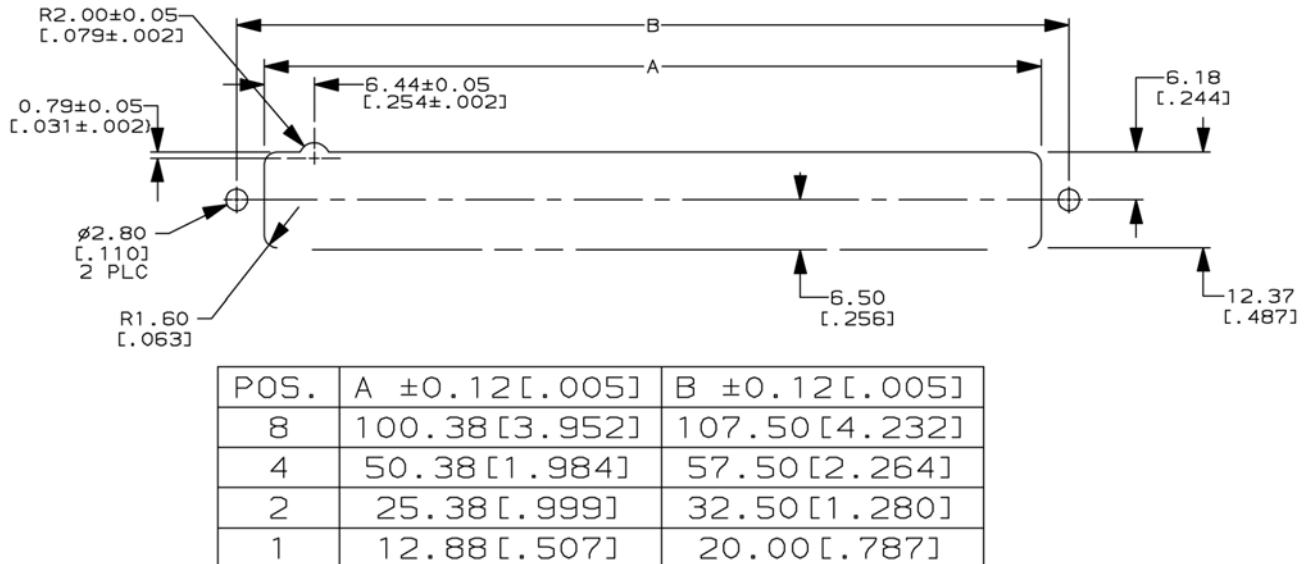

Figure 12

3.11. Fiber Bend Radius

The bend radius for fiber optic cable attached to lightplane termini is 19.05 mm [.750 in.] minimum and for single and multiple mode SC termini it is 38.1 mm [1.50 in.] minimum. Shorter bend radius could cause irreparable damage to the cable.

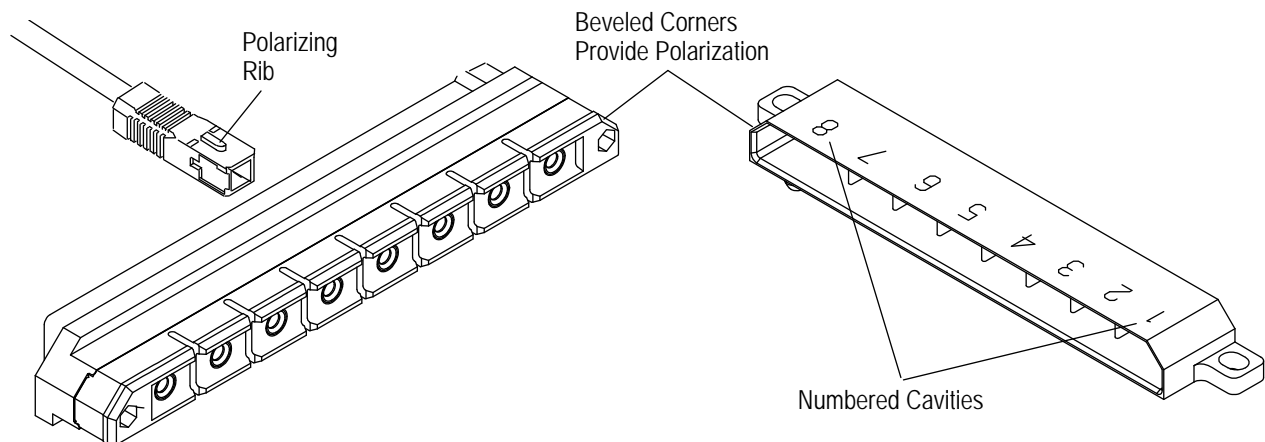

Figure 13

3.12. Polarization of Connectors

The housing are polarized by the two beveled outside corners on the motherboard housing which are designed to mate with the beveled inside corners on the daughterboard housing and prevent mismatching of connectors. The daughterboard connector has numbered cavities to identify circuits. The SC termini have a polarizing rib that must be aligned with the polarizing slot in the motherboard housing. See Figure 13.

3.13. Mounting Hardware

There is unique mounting hardware for each of the connectors. There are jackscrews for mounting the motherboard to a panel which include a guide pin to help align mating connectors. Hardware for mounting the daughterboard to a pc board consists of a shoulder screw and self-locking nut. The standoff on the shoulder screw is longer than the housing mounting ear. This feature allows the hardware to be securely tightened while providing floating action for the connector and facilitate mating. See Figure 14.

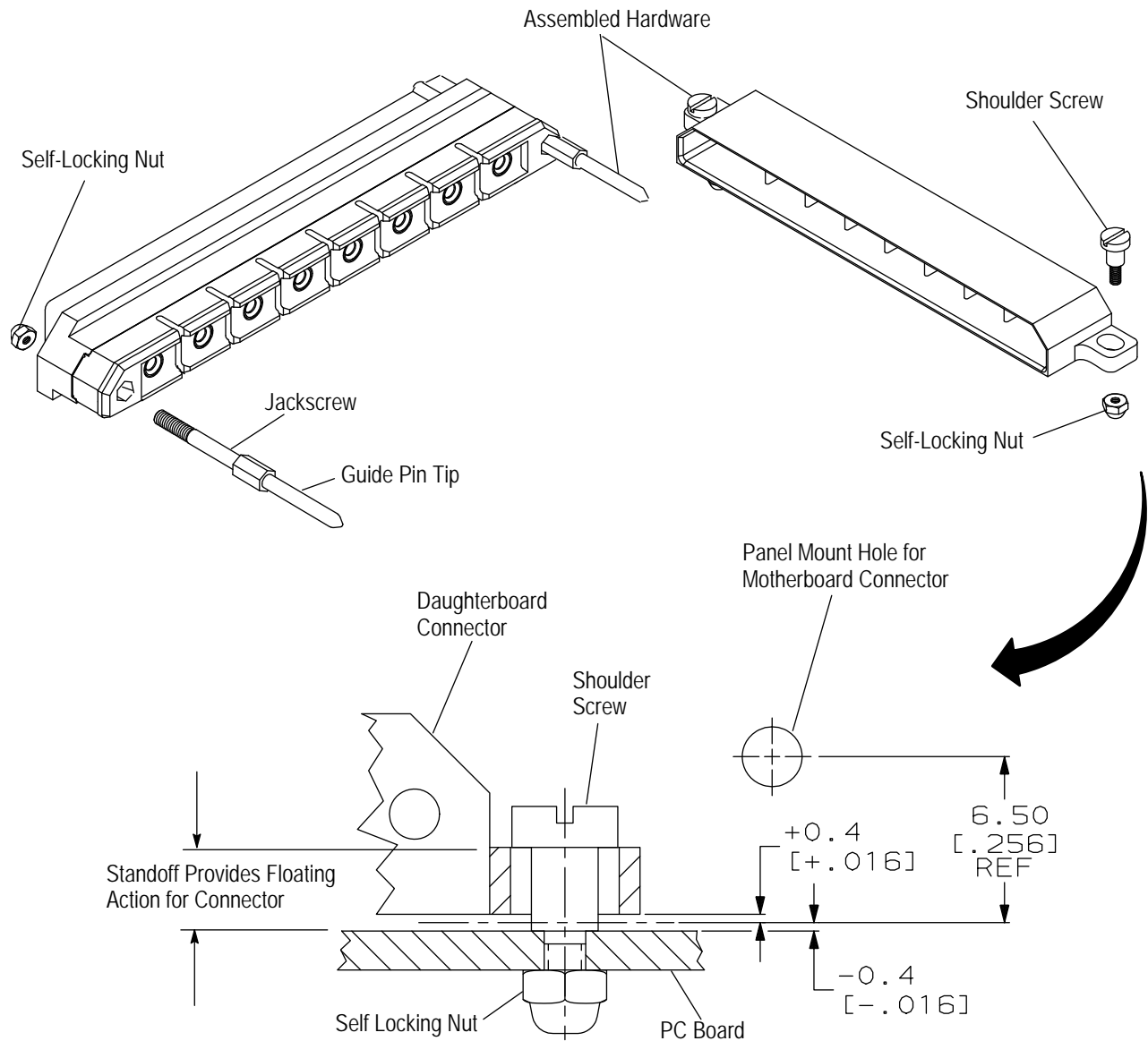

Figure 14

3.14. Ancillary Items

A. Protective Devices

Dust covers are available for each terminus and must be used when the terminus is not inside the connector housing to prevent inadvertent damage. There are also dust covers for assembled connectors which also must be used when the connectors are not mated. Fiber protectors and curing sleeves are designed to protect the fiber optic during curing of the epoxy. See Figure 15.

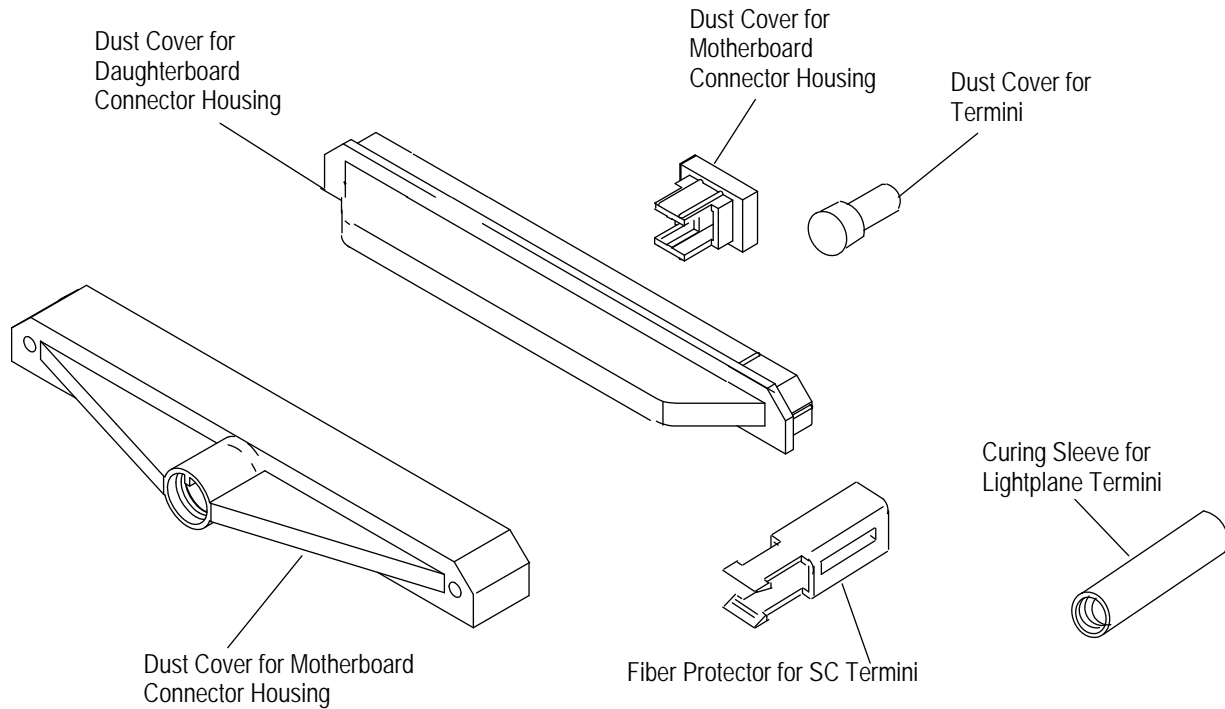

Figure 15

B. Extension Rod

Extension rods are available to install and remove protective covers from motherboard connectors which may be located in a close fitting system that would make it difficult to reach the connector. These extension rods thread into the protective cover and can be removed when not needed. If the extension rod has a chamfer slightly above the threaded area, then the threaded rod must be threaded into the dust cover until the chamfer firmly meets the chamfer on the dust cover. This is to ensure tool strength. See Figure 16.

Cross-Section of Extension Rod Bottomed in Dust Cover

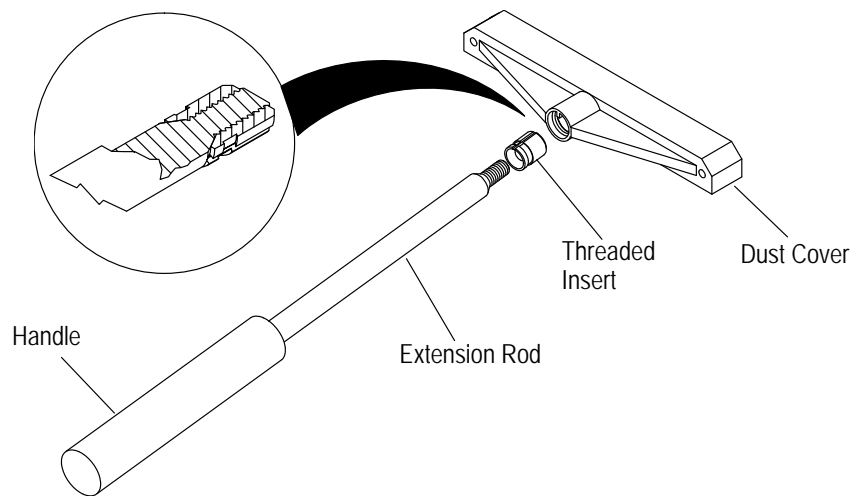

Figure 16

4. QUALIFICATION

No agency qualifications are required for Lightplane Connectors.

5. TOOLING

The various tools, equipment, and instructions available for terminating and inspecting termini used in Lightplane Connectors are shown in Figure 17.

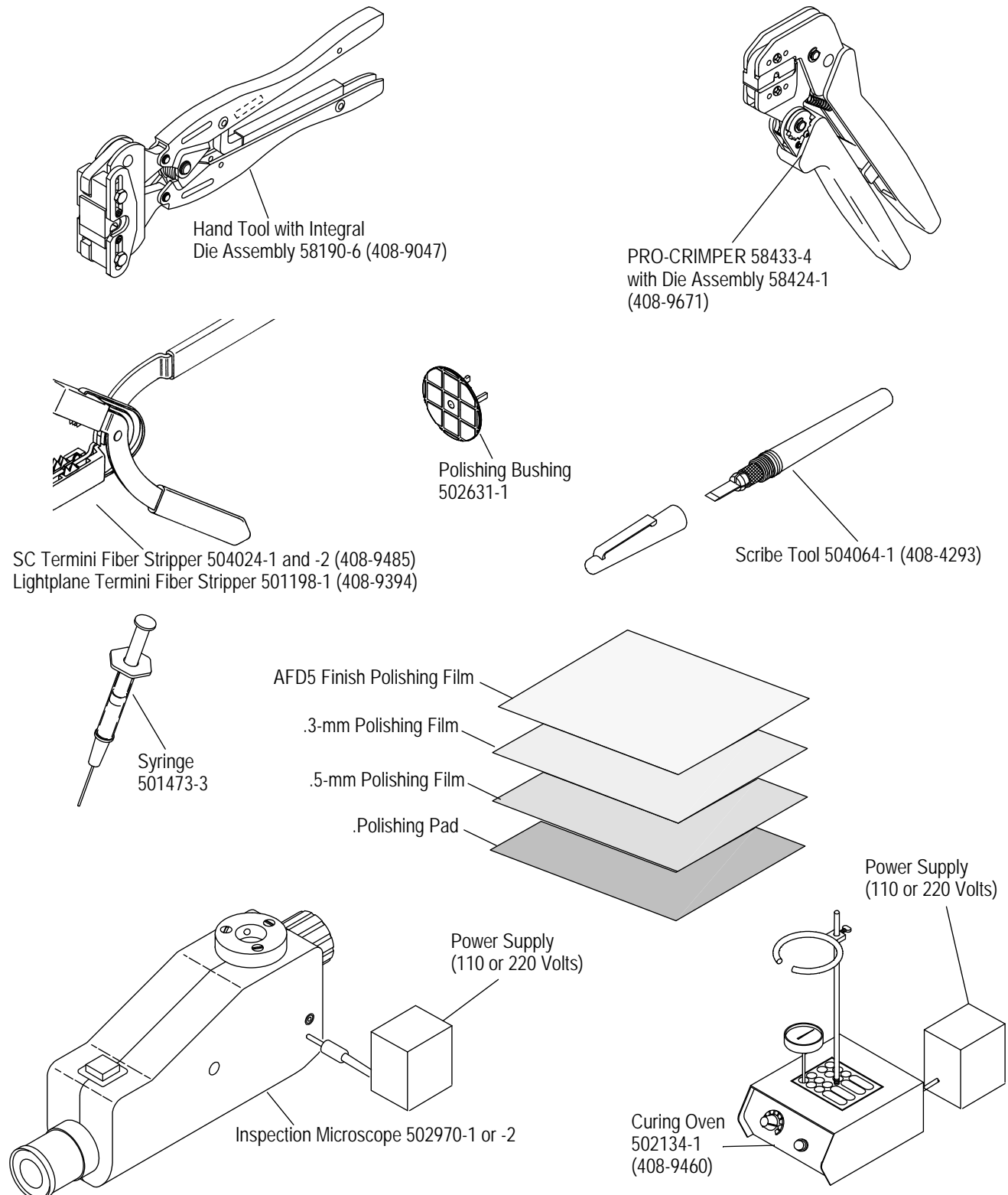

Figure 17

6. VISUAL AID

The illustration below shows a typical application of this product. This illustration should be used by production personnel to ensure a correctly applied product. Applications which DO NOT appear correct should be inspected using the information in the preceding pages of this specification and in the instructional material shipped with the product or tooling.

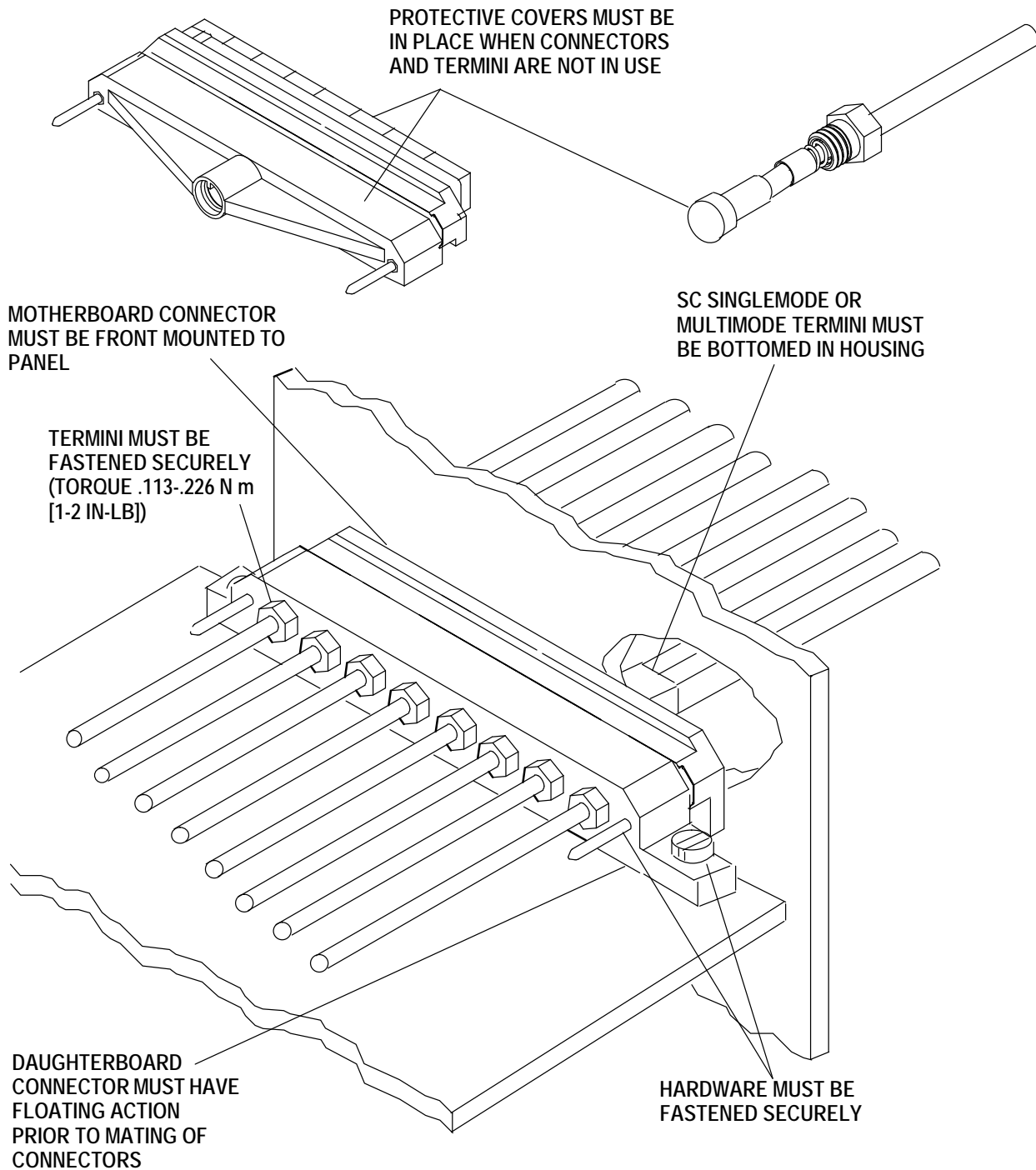

FIGURE 18. VISUAL AID