

HSD, Pin Headers 90°/ 180°, die-casting

CONTENT

1. DESCRIPTION	2
2. PACKAGING OF PIN HEADER	2
3. PLACEMENT OF PIN HEADER TO PCB	3
4. SOLDERING PROCESS OF PIN HEADER	7
5. ASSEMBLY OF PIN HEADER WITH DEVICE HOUSING AND MATING WITH CABLE CONNECTOR	9
6. HISTORY OF CHANGE	10

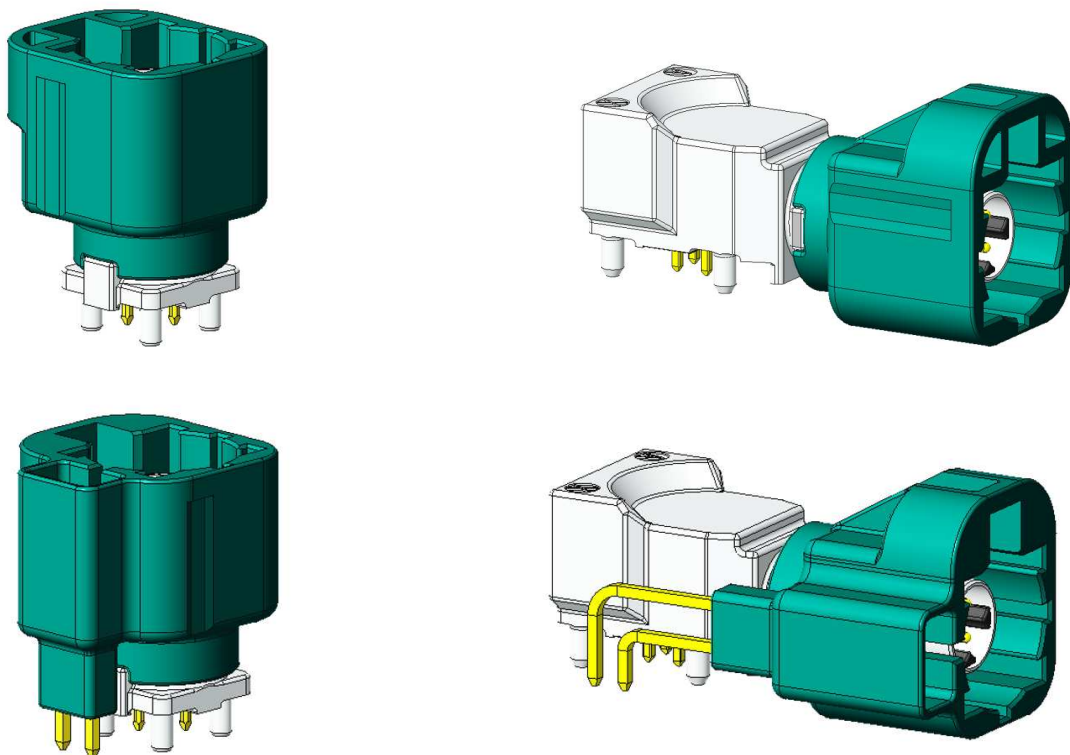

Fig. 1: Pin Header Variant

1. DESCRIPTION

The application specification includes handling recommendations for the direct assembly of the HSD-header on the PCB.

2. PACKAGING OF PIN HEADER

2.1 DELIVERY CONDITION

The HSD pin header will be delivered in tape and reel packaging, which is sealed and with desiccant to keep the package environment in a dry condition.

The material from tape and reel is polystyrene. It fulfills the ESD requirement surface resistance 10^9 - 10^{11} Ω/m

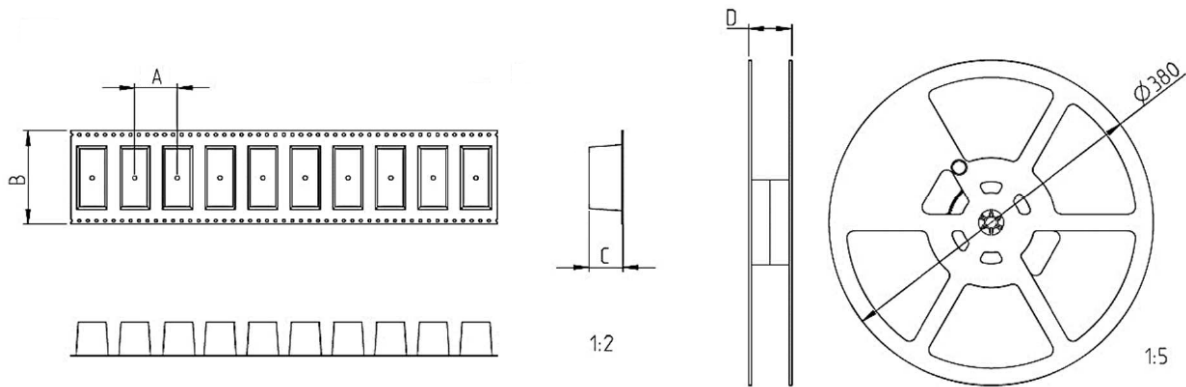
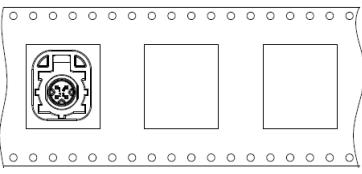
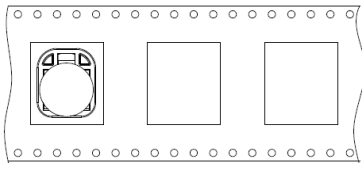
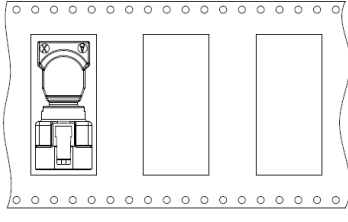
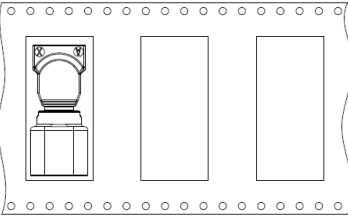
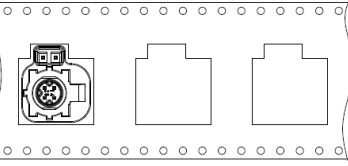
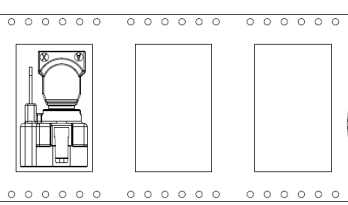

Fig. 2: Packaging Dimensions [mm]

TE number, Coding	Unwinding direction loaded ←	Dimensions [mm]				Quantity on reel
		A	B	C	D	
HSD Header 180° X-2291364-X A, B, C, D, E, F, Z, G, H, J, K, L, M, O		24	32	19.1	37.5	160 pieces
HSD Header 180° X-2304935-X A, B, C, D, E, F, Z, G, H, J, K, L, M, O		24	32	19.9	37.5	150 pieces

<p>HSD Header 90° 0-2291362-X A, B, C, D, E, F, Z 2-2291362-X A, B, C, D, E, F, Z</p>		<p>24</p>	<p>44</p>	<p>15.1</p>	<p>49.5</p>	<p>210 pieces</p>
<p>HSD Header 90° 1-2291362-X G, H, J, K, L, M, O 3-2291362-X G, H, J, K, L, M, O</p>		<p>24</p>	<p>44</p>	<p>15.5</p>	<p>49.5</p>	<p>210 pieces</p>
<p>HSD Header 180° with 2 MQS Pin's 0-2315239-X A, B, C, D, E, F, Z</p>		<p>24</p>	<p>32</p>	<p>18.6</p>	<p>37.5</p>	<p>110 pieces</p>
<p>HSD Header 90° with 2 MQS Pin's 0-2315834-X A, B, C, D, E, F, Z</p>		<p>28</p>	<p>44</p>	<p>16</p>	<p>49.5</p>	<p>160 pieces</p>

For detail information of TE part number with coding, please contact TE Connectivity.

2.2 TAKING OUT FROM THE PACKAGING

Suction area: for dimension and position please check the respective customer drawing.

2.3 RECOMMENDED APPLICATION OF THE PACKAGING

It is recommended that the HSD pin header should be applied to PCB within 6 months after the production date. For the remaining HSD pin header after opening the package, it is mandatory to re-seal it as soon as possible.

3. PLACEMENT OF PIN HEADER TO PCB

3.1 PCB DESIGN

The HSD pin header can be applied to all PCB's which are suitable for reflow soldering process and have a thickness between 1 mm and 1.6 mm.

3.2 PLACEMENT

The placement by hand or by automatic handling (see chapter 2.2) is possible.



Fig. 3: HSD Header 180° TE-No. 2291364, 2304935

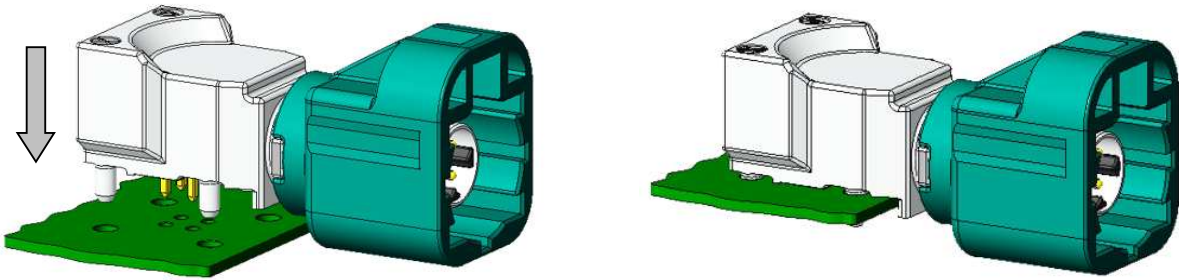

Fig. 4: HSD Header 90° TE-No. 2291362



Fig. 5: HSD Header 180° with 2 MQS TE-No. 2315239

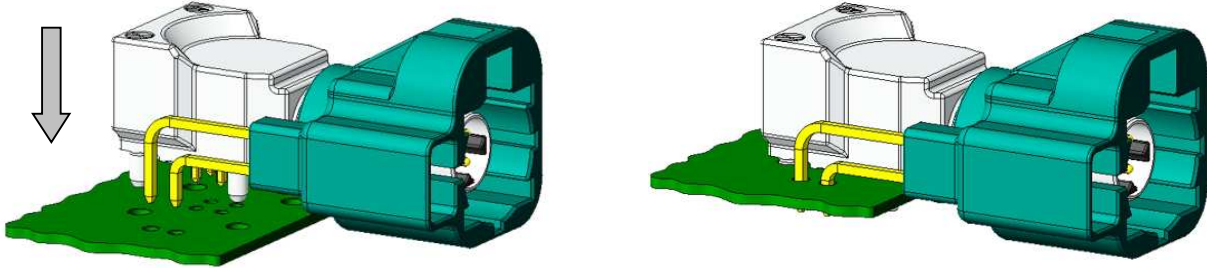

Fig. 6: HSD Header 90° with 2 MQS TE-No. 2315834

3.3 PCB LAYOUT

The size of the hole and the tolerances are to be regarded as recommendation and can be adapted to own mounting and soldering conditions.
All layouts are suitable for reflow soldering process.

3.3.1 PCB LAYOUT PROPOSAL FOR HSD 180° VARIANTS

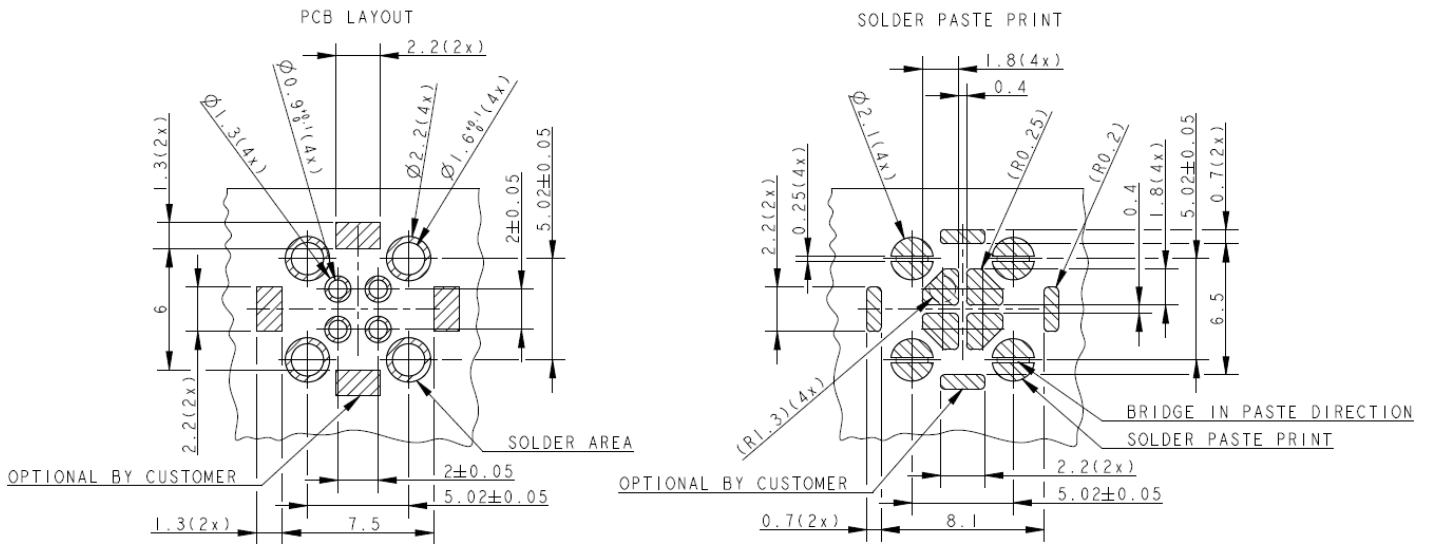

Fig. 7: Layout for HSD Header 180° TE-No. 2291364, 2304935

3.3.2 PCB LAYOUT PROPOSAL FOR HSD 90° VARIANTS

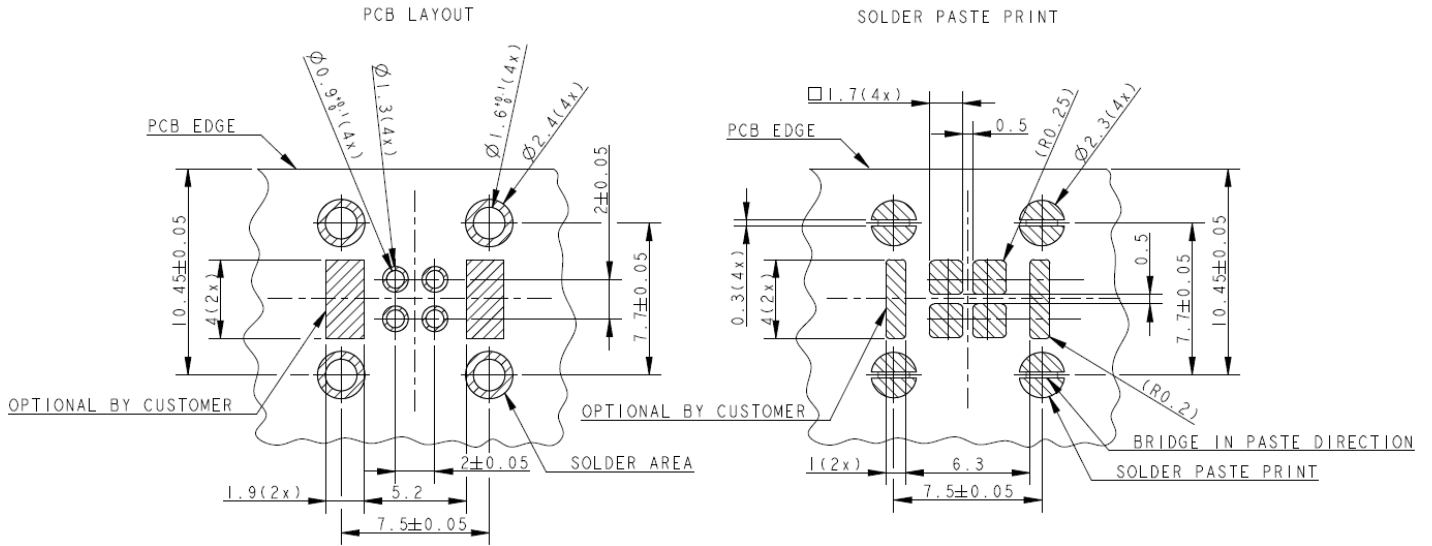

Fig. 8: Layout for HSD Header 90° TE-No. 2291362

3.3.3 PCB LAYOUT PROPOSAL FOR HSD 180° VARIANT WITH 2 MQS CONTACTS

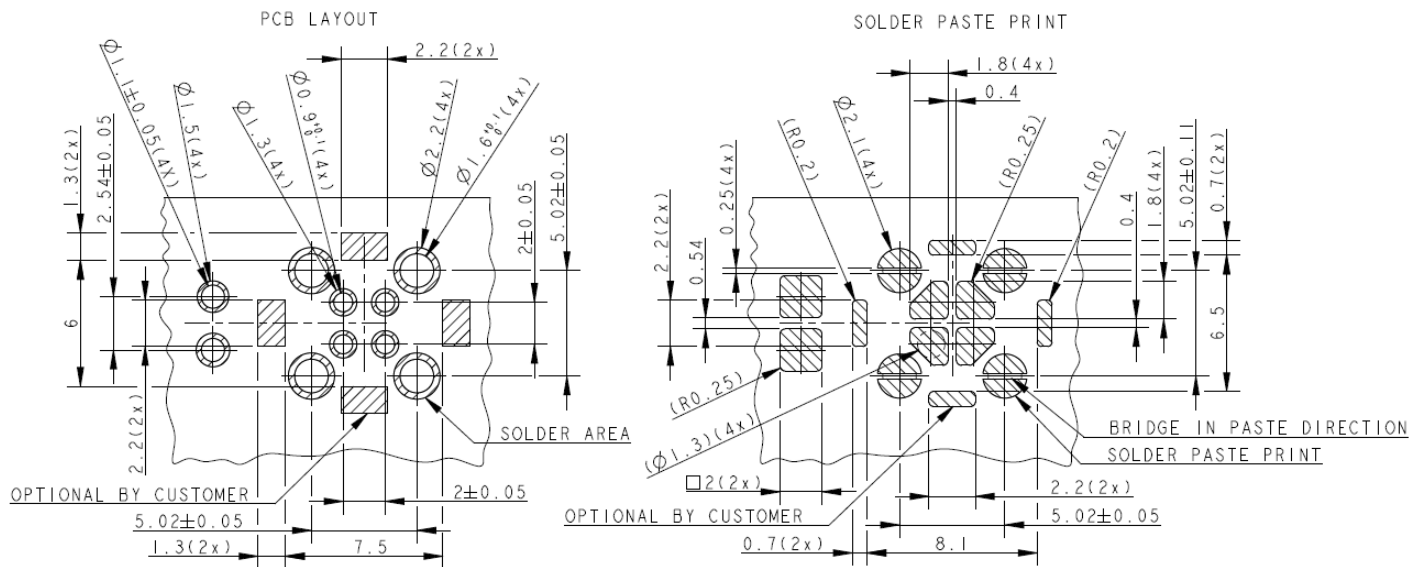

Fig. 9: Layout for HSD Header 180° with 2 MQS TE-No. 2315239

3.3.4 PCB LAYOUT PROPOSAL FOR HSD 90° VARIANT WITH 2 MQS CONTACTS

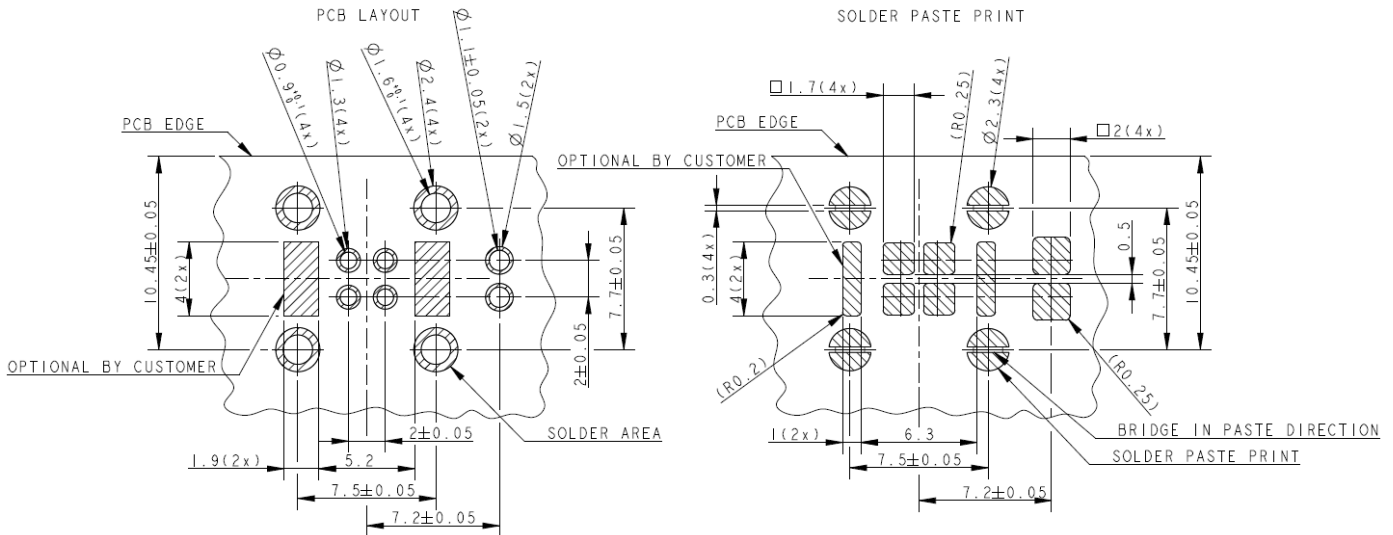

Fig. 10: Layout for HSD Header 90° with 2 MQS TE-No . 2315834

4. SOLDERING PROCESS OF PIN HEADER

It is not practicable to recommend an ideal reflow temperature profile for all situations. This depends e.g. on the used soldering paste and existing equipment. Header is designed for reflow soldering, wave soldering and hand soldering process. Recommended soldering processes only in reference to the respective soldering standard.

4.1 TEMPERATURE RESISTANCE OF THE COMPONENTS

The pin header are heat resistant according to:

Soldering process	Procedure
Lead-free reflow soldering	In reference to JEDEC J-STD-020D

The pin header is made for one time soldering process.

4.2 RECOMMENDED PARAMETERS FOR THE REFLOW SOLDERING PROCESS

Reflow soldering according to IPC / JEDEC J-STD-020D.
The soldering process needs to be performed with protective gas.

4.2.2 SOLDERING PASTE

Recommended soldering paste: Type 3, lead-free (Senju M31-GRN360-K1MKV)

4.2.3 SOLDERING PASTE STENCIL

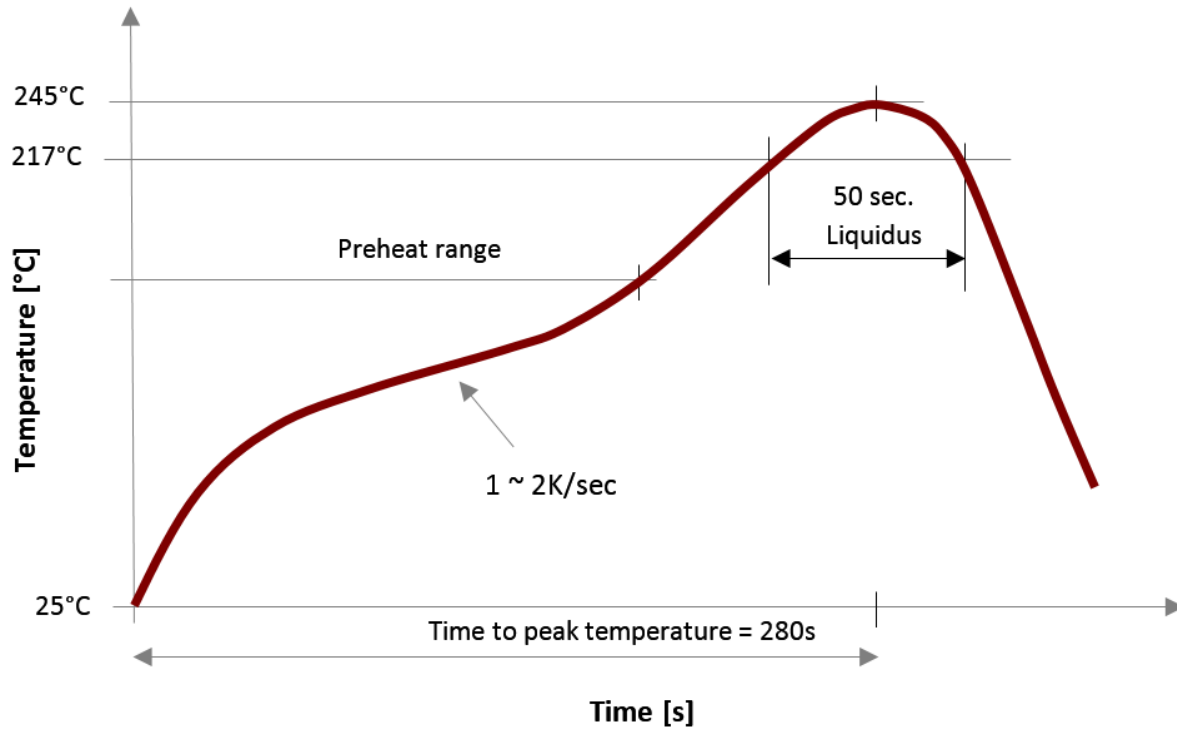

Soldering paste thickness 0.15 mm on the component side.
Layout of solder paste print see chapter 3.3
The layouts are created for an open scraper system.

4.3 JUDGEMENT OF THE SOLDERING JOINT

Micrograph: For an optimal soldering joint it is necessary to have at least a 75% through hole soldering.

Judgement of the soldering joint will be done by optical inspection according to the acceptance criteria of IPC A610.

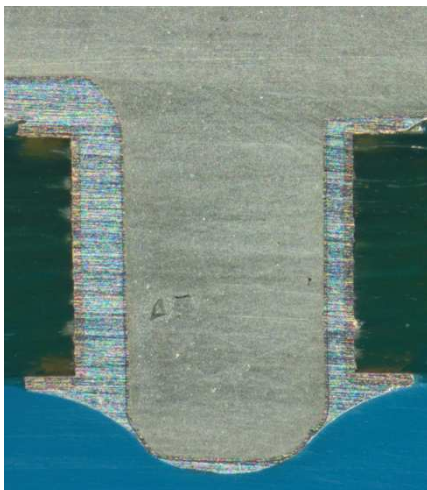

Micrograph from reflow shield pin

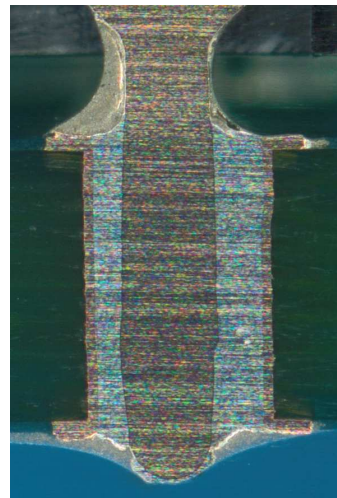

Micrograph from reflow signal pins

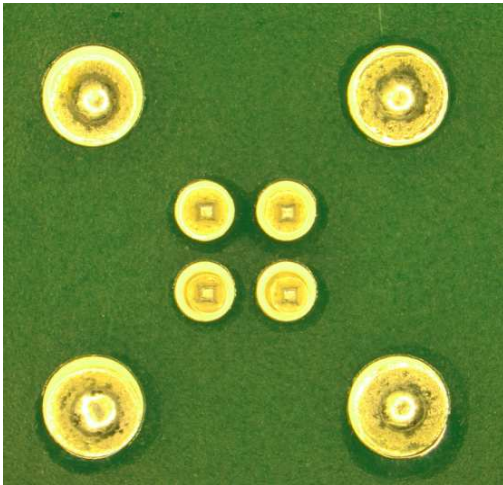

Soldering

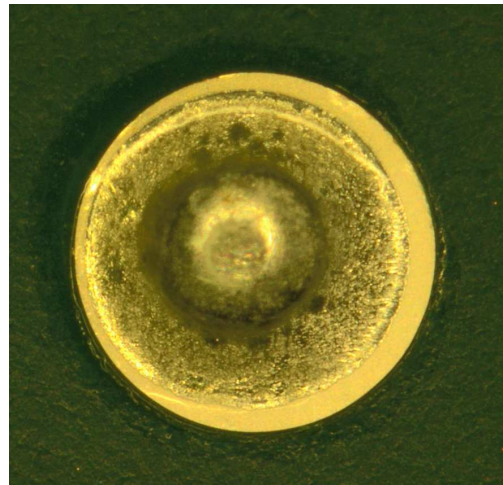

Soldering shield pin

5. ASSEMBLY OF PIN HEADER WITH DEVICE HOUSING AND MATING WITH CABLE

The construction of the control unit is different from tier1 to tier1. It is not possible to give a general design specification. Dimensions of coding cover can be taken from the customer drawing.

TE gives following non-binding recommendations:

- Distance to the coding cover: 0.5 mm around
- Locking window should not be covered
- Sideway notch can be used for geometric fit in
- Follow the orientation when plugging

Orientation of cable connector and assembly in this direction. (see Arrow)

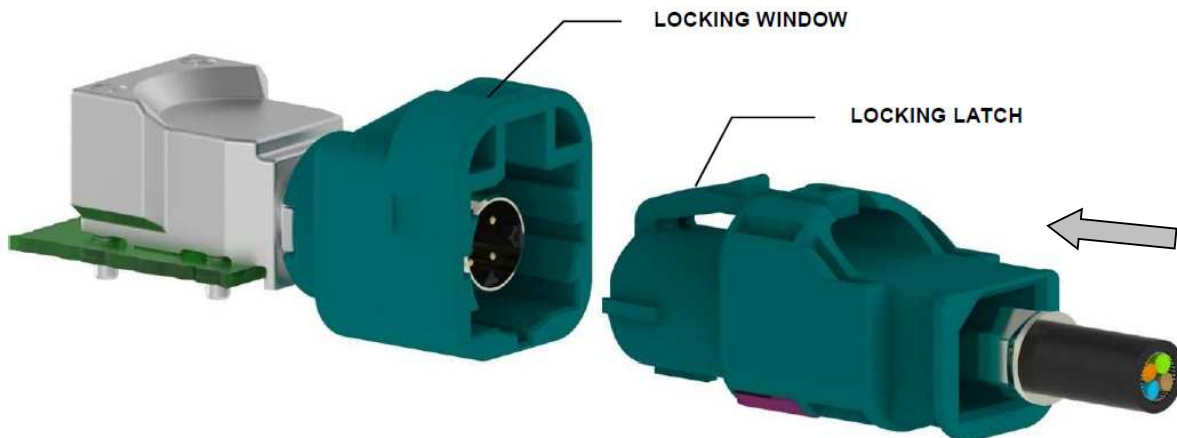

Fig. 11: Assembly with cable connector



6. History of change

Revision	Sheet	Change	Date
A	1-10	New document	09. Aug. 2018