



**NOTE**

All numerical values are in metric units [with U.S. customary units in brackets]. Dimensions are in millimeters [and inches]. Unless otherwise specified, dimensions have a tolerance of  $\pm 0.13$  mm [ $\pm .005$  in.] and angles have a tolerance of  $\pm 2^\circ$ . Figures and illustrations are for identification only and are not drawn to scale.

**1. INTRODUCTION**

This specification covers the requirements for application of the Underground Bus Bar Distribution System. This 600-V copper underground distribution system is an insulated, submersible junction for interconnecting stranded secondary-voltage underground cables with a wire size of 2 AWG, 3/0, 350, 500, 750, and 1000 kcmil.

The distribution system is composed of one way and two way bus bar assemblies with 4 or 6 positions, rocket sleeve assemblies, and tower cover sleeve assemblies. Based on customer requirements, various NEMA sized 2-hole lug connectors may be purchased separately from TE Connectivity.

When corresponding with TE Personnel, use the terminology provided in this specification to facilitate your inquiries for information. Basic terms and features of this product are provided in Figure 1.

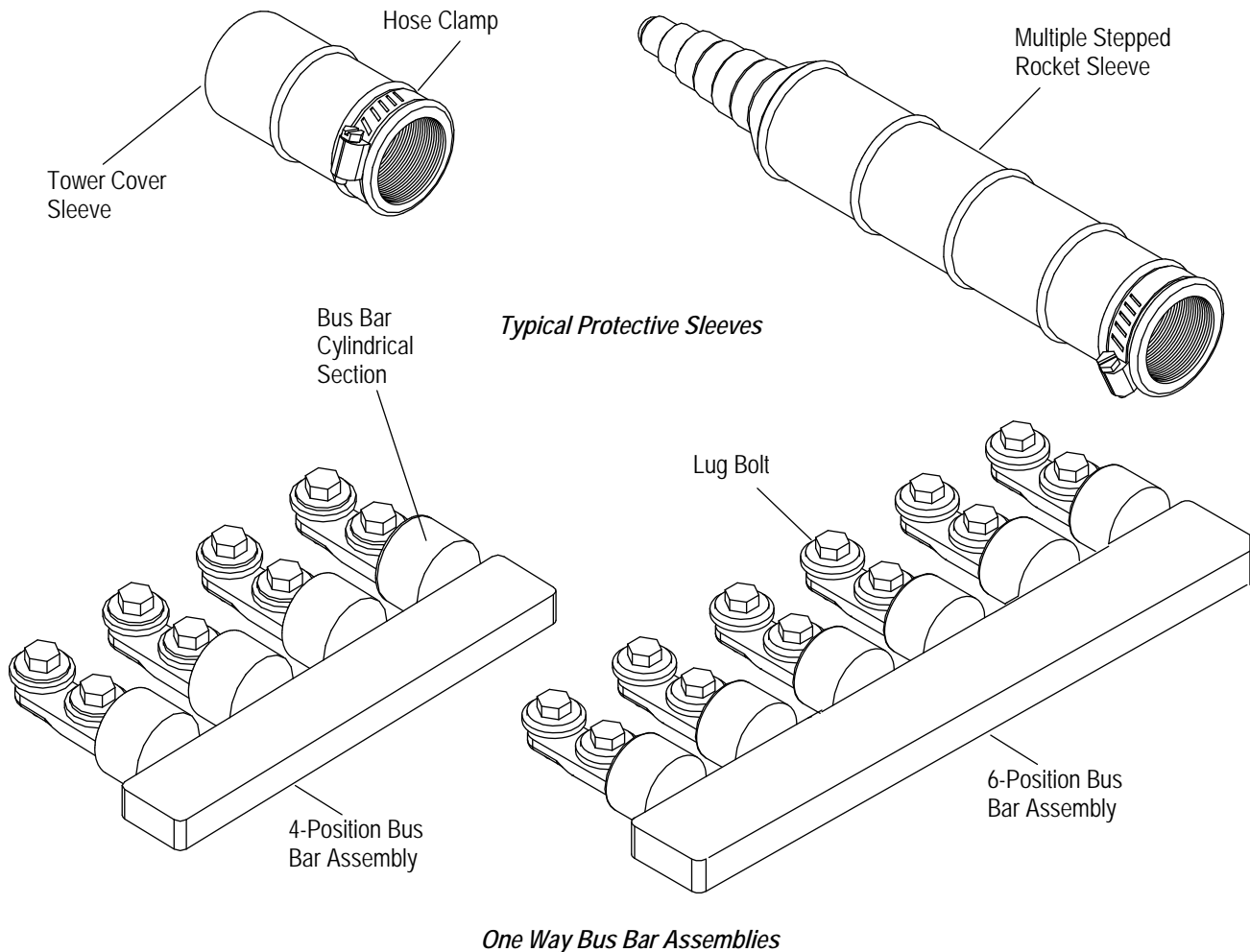

Figure 1 (Cont'd)

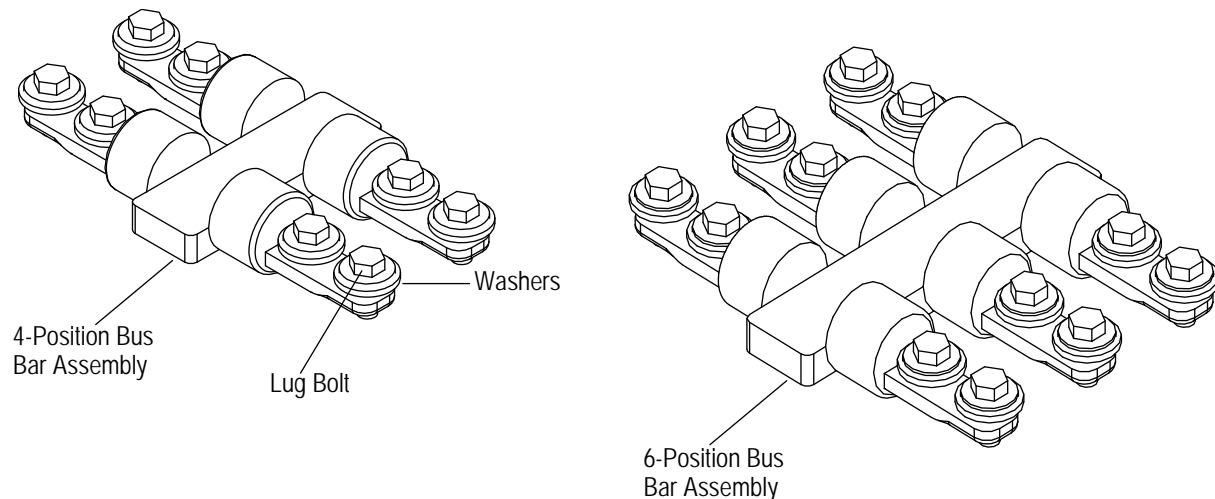

Figure 1 (End)

## 2. REFERENCE MATERIAL

### 2.1. Revision Summary

Revisions to this application specification include:

- Updated document to corporate requirements
- Deleted previous company name and logo
- Updated text in Paragraph 2.2

### 2.2. Customer Assistance

Reference Product Base Part Number 109339 and Product Code 4681 are representative numbers of the Underground Bus Bar Distribution System. Use of these numbers will identify the product line and help you to obtain product and tooling information. Such information can be obtained through a local TE Representative, by visiting our website at [www.te.com](http://www.te.com), or by calling PRODUCT INFORMATION or the TOOLING ASSISTANCE CENTER at the numbers at the bottom of page 1.

### 2.3. Drawings

Customer Drawings for specific products are available from the service network. The information contained in Customer Drawings takes priority if there is a conflict with this specification or with any technical documentation supplied by TE.

### 2.4. Safety Material

Material Safety Data Sheets (MSDS) provide safety and health information for chemicals recommended by TE. See the manufacturer's MSDS for inhibitors recommended in this document.

## 3. REQUIREMENTS

### 3.1. Storage

The distribution system components should remain in the shipping containers until ready for use to prevent deformation to the components. These components should be used on a first in, first out basis to avoid storage contamination.

### 3.2. Special Characteristics

The bus bar is tin plated copper, insulated with an EPDM rubber housing. This bar is fabricated for connection to standard aluminum or copper National Electrical Manufacturers Association (NEMA) two hole lugs. Bars are pre-assembled with .5-in. bolts with captive Belleville and flat washers. Bar connection positions must be protected with a tower cover sleeve when no cable is connected and a stepped rocket sleeve when a cable is connected. Both sleeves include a stainless steel hose clamp. See Figure 1.

### 3.3. Cable Selection and Preparation

#### A. Cable Selection

The rocket sleeve will accept cable and strip lengths as listed in Figure 2. Also provided are the cross section dimensions after termination.



**CAUTION**

DO NOT nick, cut, or scrape the wire conductor during the stripping operation.

CABLE	ROCKET SLEEVE STEP WIRE INDICATOR MARKING	CABLE JACKET DIAMETER (Min)	BARREL OPENING	STRIP LENGTH RANGE	BARREL CROSS SECTION mm <sup>2</sup> [in.]
2 Compressed	2	10.25 [.404]	8.0 [.315]	60-100 [2.4-4.0]	50.27 [.078]
2 STR	2	10.25 [.404]	8.5 [.335]		56.75 [.088]
3/0 Compressed	3/0	15.65 [.616]	12.0 [.472]		113.10 [.175]
3/0 STR	3/0	15.65 [.616]	13.0 [.512]		132.73 [.206]
350 Compressed	350	20.25 [.797]	17.0 [.669]		226.98 [.352]
350 STR	350	20.25 [.797]	18.0 [.709]		254.47 [.394]
500 Compressed	500	23.3 [.917]	19.5 [.768]		298.65 [.463]
500 STR	500	23.3 [.917]	21.5 [.846]		363.05 [.563]
750 Compressed	750	27.7 [1.091]	24.0 [.945]	74-100 [2.9-4.0]	452.39 [.701]
750 STR	750	27.7 [1.091]	26.0 [1.024]		530.93 [.823]
1000 Compressed	1000	31.5 [1.240]	28.0 [1.102]		615.75 [.954]

Figure 2

#### B. Wire Preparation

Determine the correct wire size to be used. Straighten the insulated cable and strip the insulation from the cable according to the dimensions given in Figure 2. Apply silicone grease to approximately 300 mm [12 in.] from the end of the cable jacket. See Figure 3.

#### C. Wire Bend Radius

It is important not to restrict the lug in any way that may adversely affect the wire dress of the cable. TE recommends that individual cables should be dressed to a bend radius of at least ten times the cable outside diameter. Likewise, cable bundles should be dressed to a bend radius of at least ten times the diameter of the bundle.

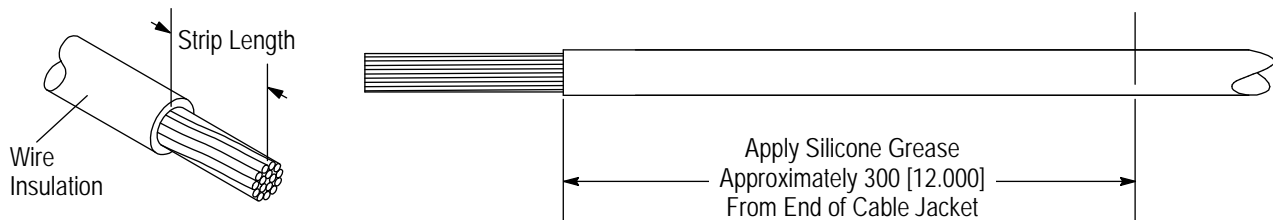

Figure 3

### 3.4. Rocket Sleeve Preparation

Cut the step of the rocket sleeve to the desired cable diameter. Leave the correct wire size indicator showing. See Figure 4.

Belleville is a trademark.

**NOTE:** Utility knife cutting for 3/0 cable as an example.

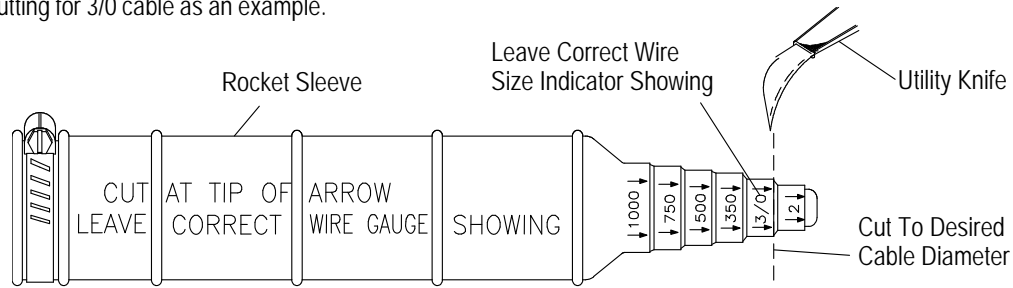

Figure 4

### 3.5. Assembly

#### A. Cable and Rocket Sleeve

Slide the cut end of the rocket sleeve over the prepared end of the conductor insulation until approximately 100 mm [4 in.] length of conductor protrudes past the large end of the sleeve. See Figure 5.

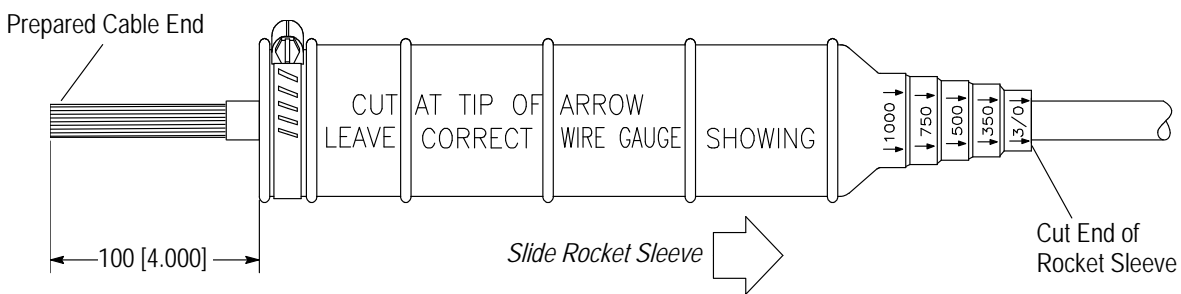

Figure 5

#### B. Cable and Lug

Install a two-hole lug on the protruding end of the conductor and terminate the lug according to the instructions packaged with the tooling. Apply TE Inhibitor, PN 83655-2 to the connecting surface of the lug. Clean the lug with a wire brush as shown in Figure 6.

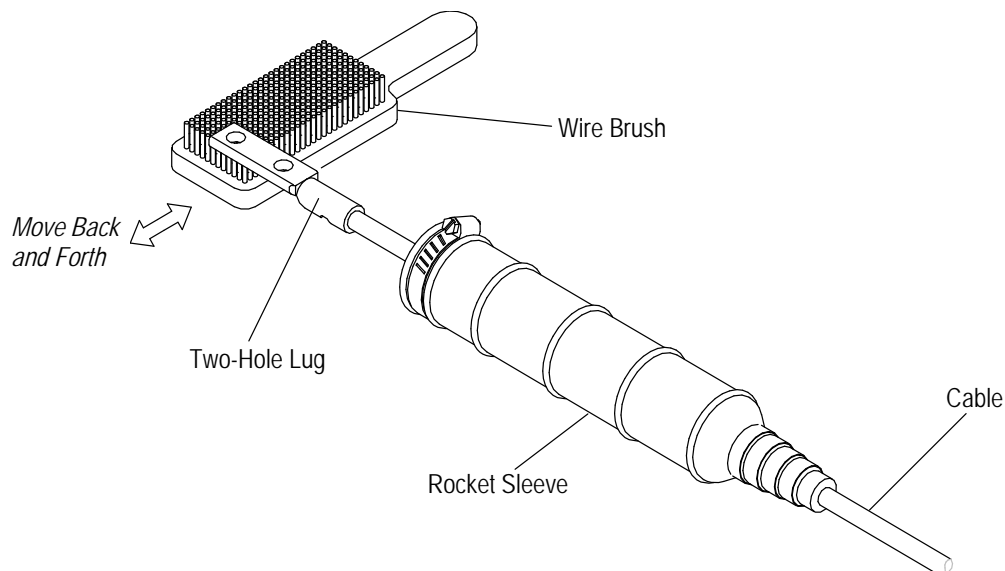

Figure 6

### C. Lug Orientation

The two-hole lug must be orientated to minimize the offset between the cable and the cylindrical sections of the bus bar. The allowable maximum offset is shown in Figure 7.

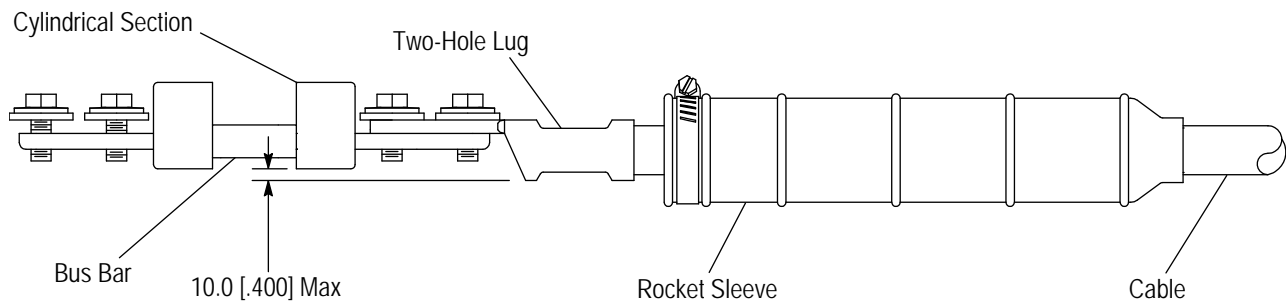

Figure 7

### D. Lugs and Bus Bar

Select either the 4- or 6-position bus bar to be used. Apply silicone grease to ALL cylindrical sections of the bus bar. See Figure 8.

Remove the .5-in. bolts from the connecting position of the bus bar. Place the lug on the bus bar and align the bolt holes. Place the bolts into the holes and finger tighten. See Figure 8.

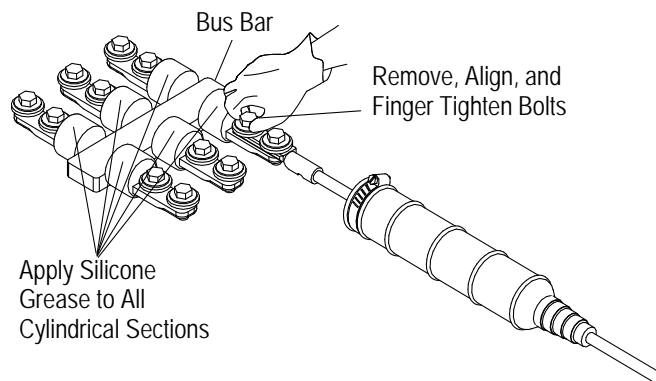

Figure 8

Place the bus bar assembly in a vertical position, hold firmly, and tighten the bolts to 40 to 50 NDm [30 to 37 ft-lb]. See Figure 9.

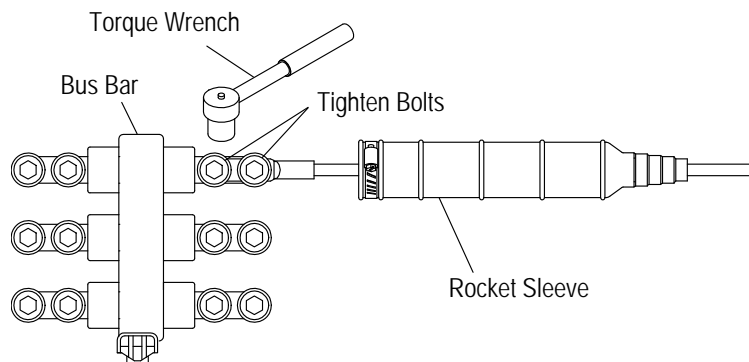

Figure 9

### E. Rocket Sleeve and Bus Bar

Slide the rocket sleeve over the bolted assembly and cylindrical section of the bus bar until it butts against the bus bar base. See Figure 10.

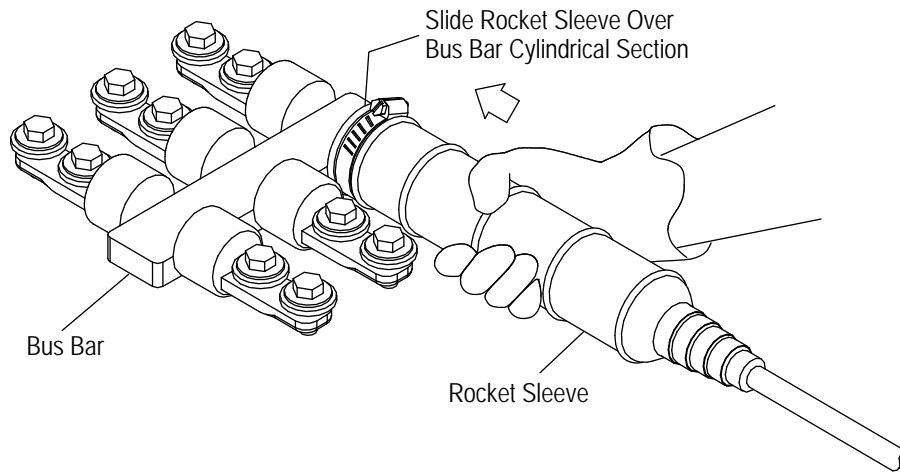

Figure 10

### F. Securing Rocket Sleeve

Secure the rocket sleeve hose clamp using a nut driver. Tighten the screw of the hose clamp four full turns from the snug position. See Figure 11.

**i** **NOTE**  
Repeat all procedures until all desired cables are connected.

**i** **NOTE**  
If more than one power line is connected to a bus bar, make sure the connections alternate.

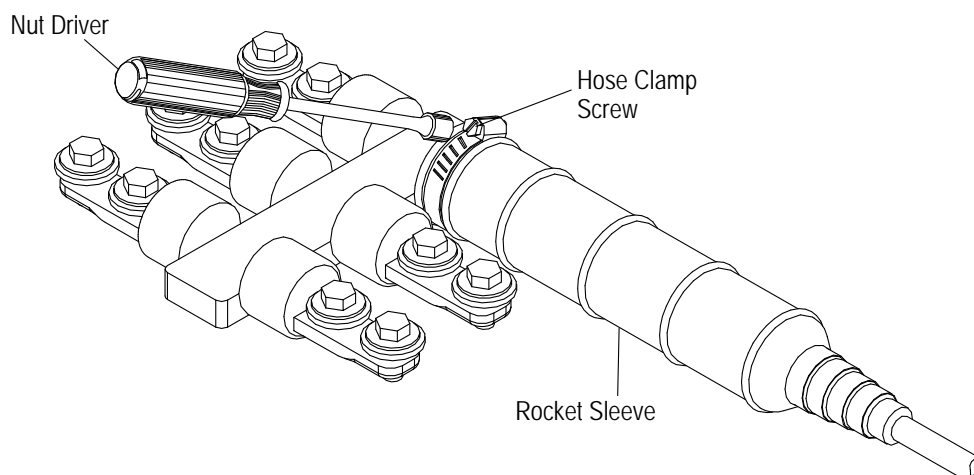

Figure 11

### G. Tower Covers and Bus Bar

Slide the tower cover sleeves over any unused bus bar positions until the open end butts against the bus bar base. See Figure 12.

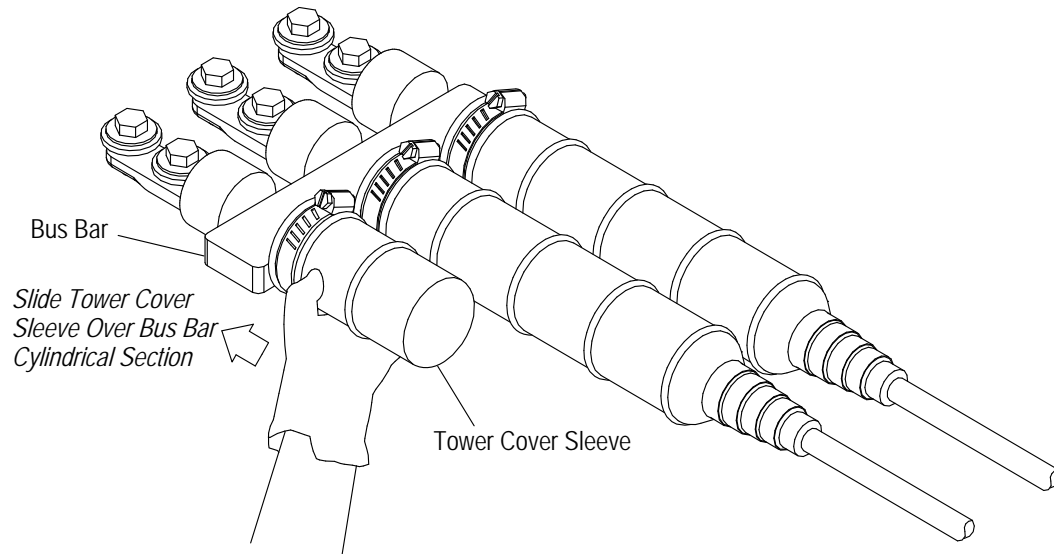

Figure 12

#### H. Securing Tower Cover Sleeves

Secure the tower cover sleeve hose clamps using a nut driver. Tighten the screw of the hose clamp four full turns from the snug position. See Figure 13.

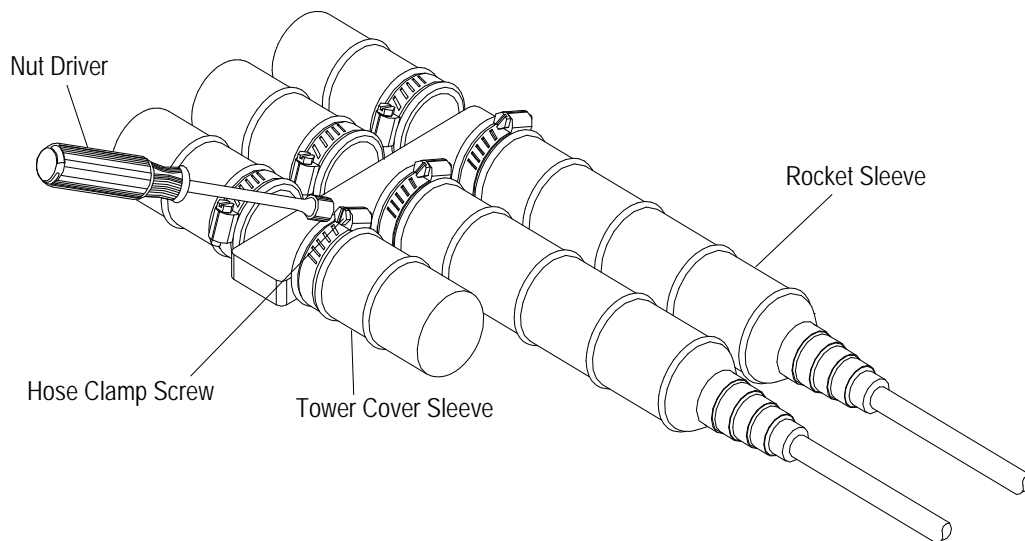

Figure 13

#### 4. QUALIFICATIONS

The Underground Bus Bar Distribution System is qualified to ANSI C119.1. The Underground Bus Bar Distribution System also satisfies and exceeds customer submersion tests of 3 meters [10 feet].

#### 5. TOOLING

Typical facility tooling is all that is necessary for the assembly of the Underground Bus Bar Distribution System Components. Tooling such as a utility knife or equivalent, nut driver, torque wrench, wire stripper, and a wire brush should suffice. Commercially available tooling used to terminate the 2-hole lug to cable is listed in Figure 14.

CABLE SIZE	DIE ASSEMBLY	SIMEL C12• HAND TOOL
2 Compressed 2 STR	CSA 20	UCSA 20
3/0 Compressed 3/0 STR	CSA 24	UCSA 24
350 Compressed 350 STR 500 Compressed	CSA 28	UCSA 28
500 STR 750 Compressed 750 STR 1000 Compressed	CSA 30	UCSA 30

\*Product of TE Simel S.A.

Figure 14



## 6. VISUAL AID

The illustration below shows a typical application of this product. This illustration should be used by production personnel to ensure a correctly applied product. Applications which DO NOT appear correct should be inspected using the information in the preceding pages of this specification and in the instructional material shipped with the product or tooling.

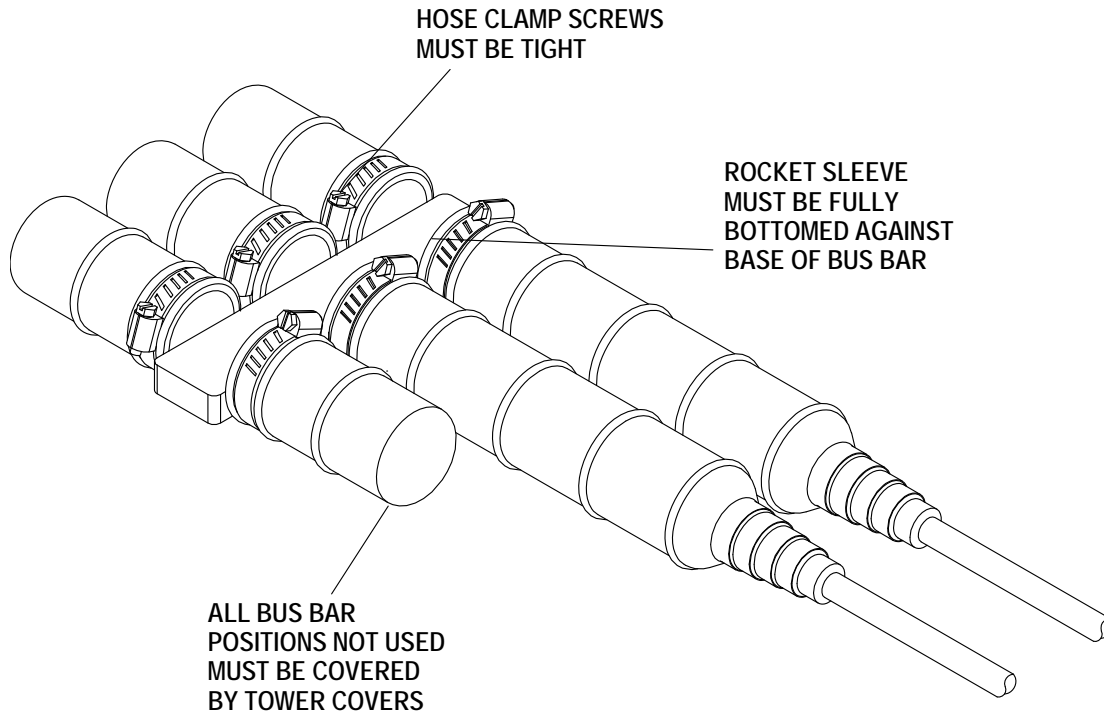

**FIGURE 15. VISUAL AID**