



## 28P Hybrid Inline Unsealed Connector Application

### 28P 混合型线-线非密封连接器产品应用规范

				PR: Huiyang Hu DATE: 20221028		TE Connectivity Shanghai, China	
				CHK: Thomson Dong DATE: 20221028			
A	Initial	HY	2022-10-28	APP: Jun Zong DATE: 20221028	Document No.: 114-160142	LOC: ES	REV: A
LTR	REVISION RECORD	PR	DATE				



Contents/目录

<b>1 GENERAL</b> .....	<b>4</b>
<b>1 综述</b> .....	<b>4</b>
1.1 Purpose .....	4
1.1 目的 .....	4
1.2 Customer Drawing/ Documents.....	4
1.2 客户图纸/文档 .....	4
<b>2 Product Description</b> .....	<b>4</b>
<b>2 产品说明</b> .....	<b>4</b>
2.1 28 Pos Tab Connector .....	4
2.1 28 位公端连接器 .....	4
2.2 28Pos Plug Connector .....	5
2.2 28 位母端连接器 .....	5
<b>3 TAB HOUSING ASSEMBLY</b> .....	<b>5</b>
<b>3 公端连接器的组装</b> .....	<b>5</b>
3.1 MALE TERMINAL INSERTION .....	6
3.1 公端子插入 .....	6
3.2 CLIP MOUNTAIN .....	6
3.2 CLIP 组装.....	6
<b>4 PLUG HOUSING ASSEMBLY</b> .....	<b>7</b>
<b>4 母端连接器的组装</b> .....	<b>7</b>
4.1 FEMALE TERMINAL INSERTION .....	7
4.1 母端子插入 .....	7
4.2 PLUG TPA INSERTION .....	8
4.2 母端 TPA 压入 .....	8
<b>5 CONNECTOR MATING AND UNMATING</b> .....	<b>8</b>
<b>5 连接器的对配组装与分离</b> .....	<b>8</b>
5.1 CONNECTOR MATING .....	8
5.1 连接器对配 .....	8
5.2 CONNECTOR UNMATING .....	9
5.2 连接器分离 .....	9
<b>6 PLUG HOUSING DISASSEMBLY</b> .....	<b>9</b>
<b>6 母端连接器的拆除</b> .....	<b>9</b>
6.1 FEMALE TPA WITHDRAW .....	9
6.1 母端 TPA 退回预锁位 .....	9
6.2 FEMALE TERMINAL REMOVAL.....	10
6.2 母端子退出 .....	10
6.2.1 0.64 Terminal Removal.....	10
6.2.1 0.64 母端子退出 .....	10
6.2.2 1.20 Terminal Removal.....	10
6.2.2 1.20 母端子退出 .....	10
6.2.3 2.80 Terminal Removal.....	11
6.2.3 2.80 母端子退出.....	11



---

<b>7</b>	<b>TAB HOUSING DISASSEMBLY</b> .....	<b>11</b>
<b>7</b>	<b>公端连接器的拆装</b> .....	<b>11</b>
7.1	MALE TPA WITHDRAW.....	11
7.1	公端 TPA 退回预锁位.....	11
7.2	MALE TERMINAL REMOVAL.....	11
7.2	公端子退出.....	11
7.2.1	0.64 Male Terminal Removal.....	11
7.2.1	0.64 公端子退出.....	11
7.2.2	1.20 Male Terminal Removal.....	12
7.2.2	1.20 公端子退出.....	12
7.2.3	2.80 Male Terminal Removal.....	12
7.2.3	2.80 公端子退出.....	12

## 1 GENERAL

### 1 综述

#### 1.1 Purpose

#### 1.1 目的

This application specification describes how to handle the 28P inline connector components.  
 本规范用于指导 28 位线对线连接器的组装，安装和返修。

#### 1.2 Customer Drawing/ Documents

#### 1.2 客户图纸/文档

This application specification is based on the latest customer drawings/Documents.  
 本应用规范是基于最新的客户图纸/文件。

C-2385449	28P TAB CONNECTOR, HYBRID, UNSEALED
C-2385446	28P PLUG CONNECTOR, HYBRID, UNSEALED
108-160272	28P HYBRID UNSEALED PRODUCTION SPECIFICATION

The document is also a reference for the application

以下文档作为此应用规范的参考文件

114-160148	REM CB Terminal Application(REM 0.64/1.2/2.8端子应用规范)
114-18464	MCON1.2 Terminal Application(MCON1.2端子应用规范)

## 2 Product Description

### 2 产品说明

The 28P unsealed inline connector system is designed for the interconnect used in car cockpit, as power and signal transmit. Contact TE engineer for more application.

28P 线对线非密封连接器设计用于汽车乘内室的信号及功率的传输。请联系 TE 工程以获取更多应用。

#### 2.1 28 Pos Tab Connector

#### 2.1 28 位公端连接器

28P TAB CONNECTOR contains below part.

28P 公端连接器组装件组成。

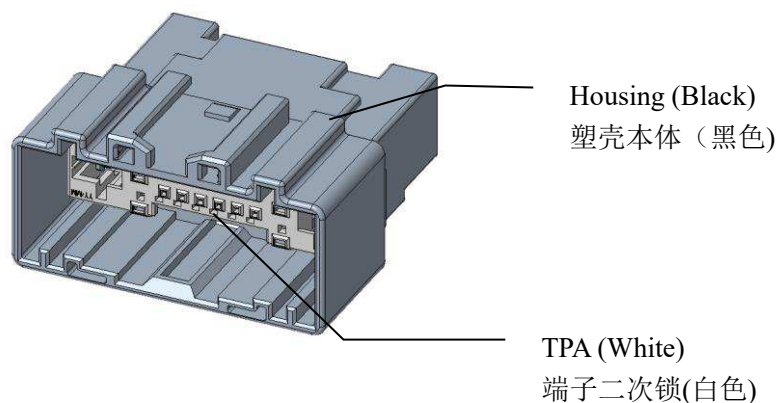

## 2.2 28Pos Plug Connector

### 2.2 28 位母端连接器

28P Plug Connector contains below part.

28P 母端连接器组装件由以下部分组成。

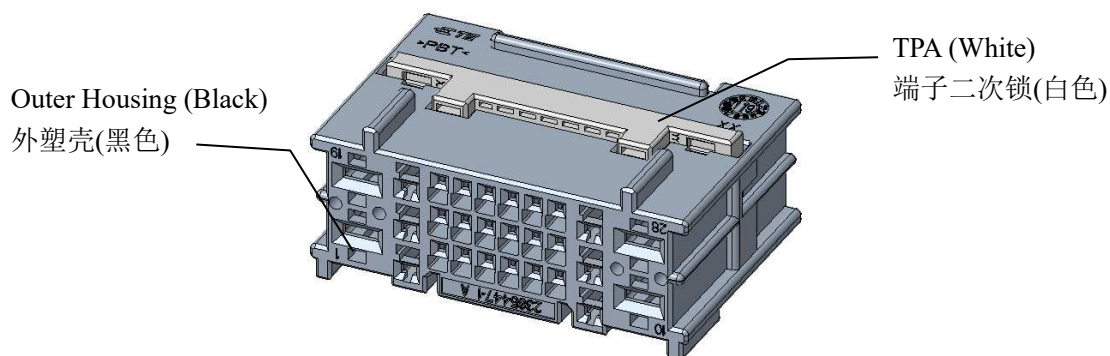

## 3 TAB HOUSING ASSEMBLY

### 3 公端连接器的组装

Check the TPA is in pre-lock position before insert terminal.

插端子前请确认 TPA 在预装位置（出货状态）

In any unexpected engaged, move it to the pre-lock position as described in § 7.1

如发现 TPA 锁上或部分锁进时，请参考 7.1 节操作，将 TPA 退到预锁位。

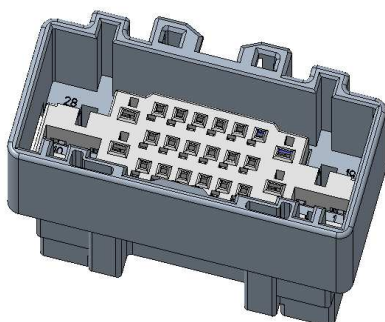

TPA in pre-lock

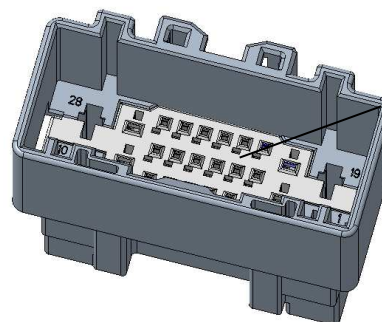

TPA surface reaches housing surface  
 二次锁表面与塑壳表面齐平

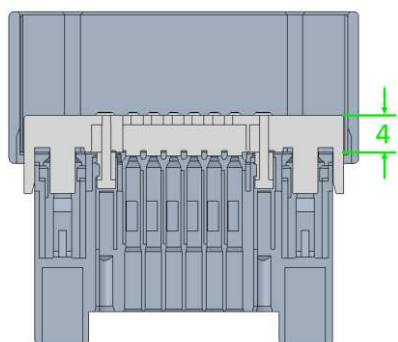

TPA in pre-lock (4 mm above housing)

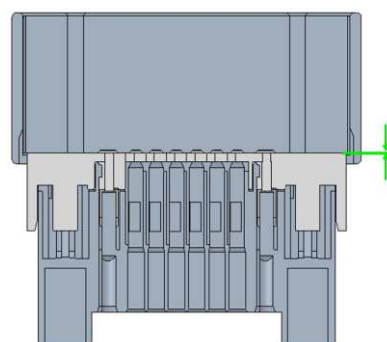

TPA in final lock

### 3.1 MALE TERMINAL INSERTION

#### 3.1 公端子插入

A. Insert the terminal (as below direction) as far as the end of the spring engages and produces an audible click. Complete locking can be examined by gently pulling back the terminal.

A. 按照如下图所示方向插入对应端子，插入到位后有轻脆咔嚓声。为确保插入到位，需轻微回拉线材检查。

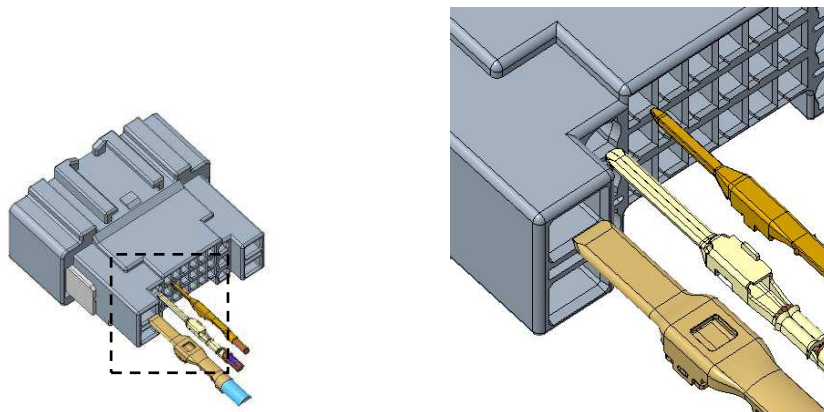

PLEASE DO NOT INSERT INCORRECT TERMINALS INTO CAVITY HOLE IN FORCE.  
需注意不能将不同种类的端子强行组装到塑胶孔中去。

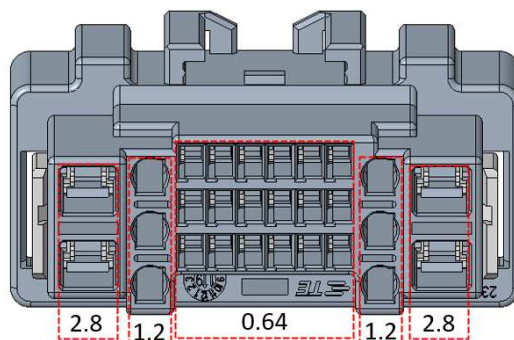

### 3.2 CLIP MOUNTAIN

#### 3.2 CLIP 组装

The clip structure is designed for several type Clip. Select proper clip for special application.  
卡板槽的设计适用多种卡钉，请结合实际应用选用适当的卡钉。

Push the clip along the slot until the lock position when an audible click feedback.

将卡钉沿卡槽推压到锁定位置，锁定时会听到“滴”的到位声。

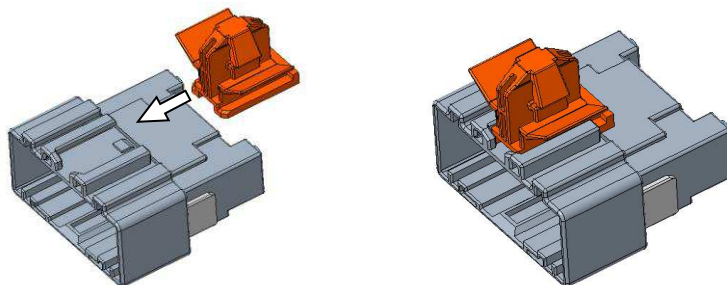

## 4 PLUG HOUSING ASSEMBLY

### 4 母端连接器的组装

Check the TPA is in pre-lock position before insert terminal.

插端子前请确认 TPA 在预装位置（出货状态）

In any unexpected engaged, move it to the pre-lock position as described in chapter 6.1

如发现 TPA 锁上或部分锁进时，请参考第 6.1 节操作，将 TPA 退到预锁位。

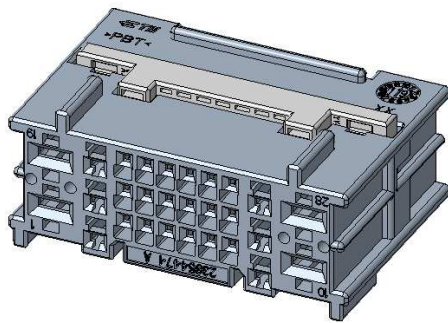

TPA in pre-lock (1.1 mm above housing)

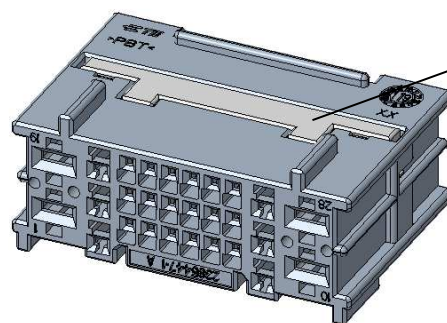

TPA in final lock

TPA surface reaches housing surface  
二次锁表面与塑壳表面齐平

### 4.1 FEMALE TERMINAL INSERTION

#### 4.1 母端子插入

A. Insert the terminal (as below direction) as far as the end of the spring engages and produces an audible click. Complete locking can be examined by gently pulling back the terminal.

A. 按照如下方向插入端子，插入到位后有轻微咔嗒声。为确保插入到位，可轻微回拉线材检查。

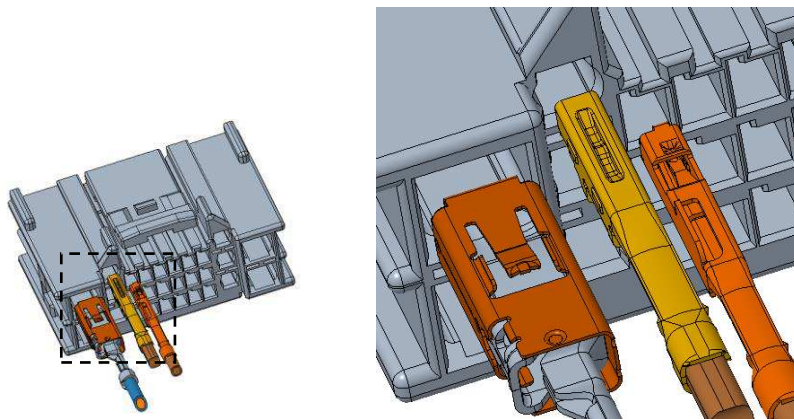

2.80 1.20 0.64



PLEASE DO NOT INSERT INCORRECT TERMINALS INTO CAVITY HOLE IN FORCE.

需注意不能将不同类型的端子强行组装到塑胶孔中去。

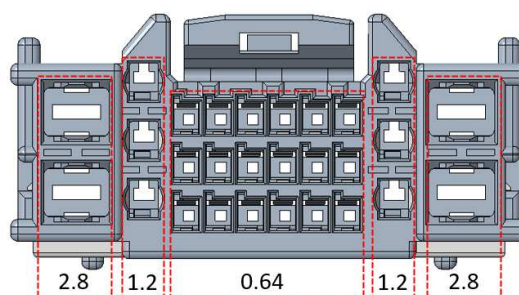

## 4.2 PLUG TPA INSERTION

### 4.2 母端 TPA 压入

A. After terminal mounted, push the TPA surface from pre-lock position until it blocked at final position.

A. 端子组装后，轻压 TPA(如图示)，使其从预锁位置压入到终锁位置。

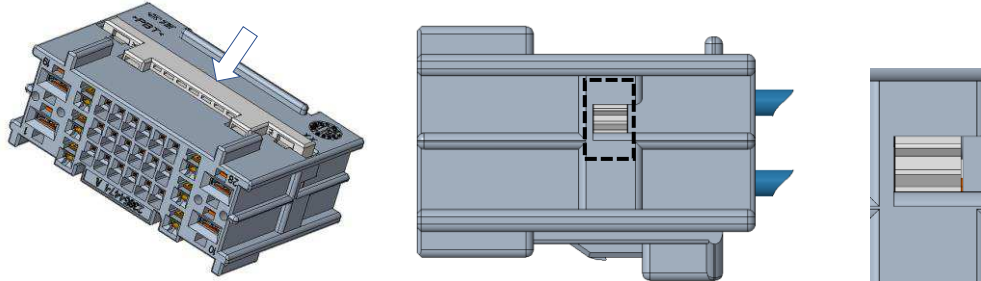

B. Check the finger located in final lock location

B. 确认两侧的卡点都落入图示上侧的槽内（上图右）

**i** Note 1: If the TPA does not fully close, MOVE it to the pre-lock position, ensure that all contacts are fully seated, then try again. **DO NOT force the TPA to close.**

如果 TPA 无法组装到位，请将 TPA 退到预锁位置，确认每个端子都插入到位后再次锁 TPA。切不可在端子未插入到位时强行锁上 TPA。

**i** Note 2: An audible click occurs when TPA reach in final lock position.  
TPA 推到位时会有“滴”声响应。

## 5 CONNECTOR MATING AND UNMATING

### 5 连接器的对配组装与分离

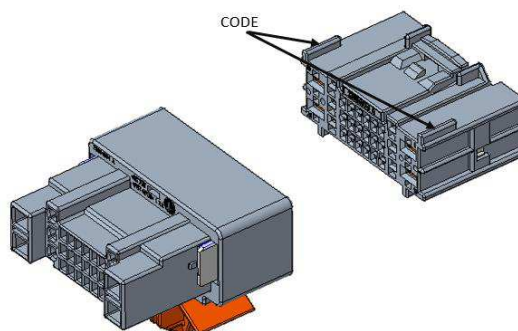

Polarization Feature (CODE)

产品不同筋位区分

## 5.1 CONNECTOR MATING

### 5.1 连接器对配

A. grab the side surface and push the plug into the male connector until full mated, an audible click occurs.

A. 握住母端两侧面将连接器与公端对配，到位时会有滴声回应。



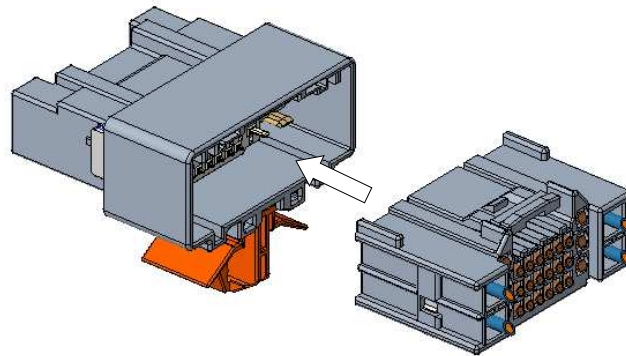

## 5.2 CONNECTOR UNMATING

### 5.2 连接器分离

- A. Push plug latch to release from male connector and then pull the plug until it separated.  
A. 按压母端卡扣直至解锁，然后将母端从公端拉离。

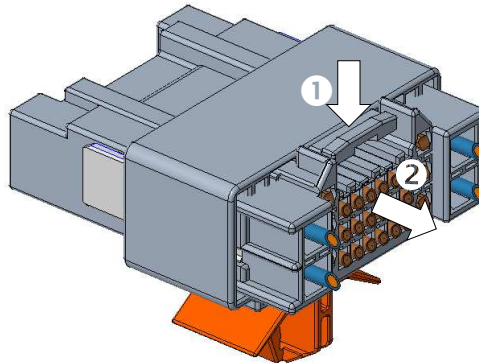

## 6 PLUG HOUSING DISASSEMBLY

### 6 母端连接器的拆除

#### 6.1 FEMALE TPA WITHDRAW

#### 6.1 母端 TPA 退回预锁位

- A. Use a tool to insert the slot and rotate the tool so that the TPA can move outward until to its pre-lock position.  
A. 将工具伸入槽孔并旋转，直至 TPA 到其预锁位置。

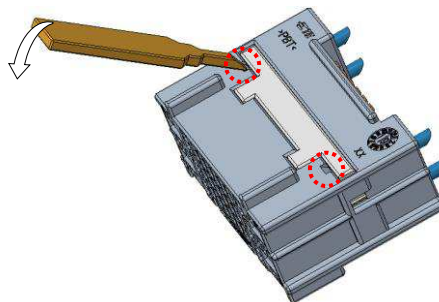

## 6.2 FEMALE TERMINAL REMOVAL

### 6.2 母端子退出

#### 6.2.1 0.64 Terminal Removal

#### 6.2.1 0.64 母端子退出

- A. Insert releasing pin along the terminal surface and till stop position as shown.  
A. 将退端子工具沿端子表面推至图示位置。

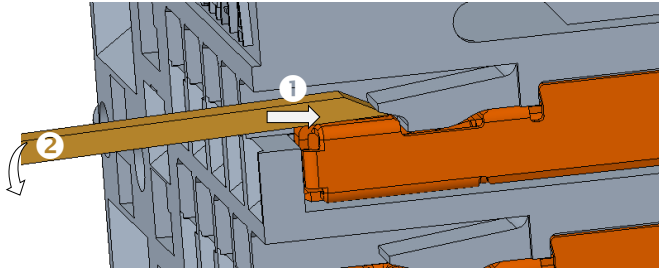

- B. Rotate and hold releasing pin and then pull the wire out of cavity.  
B. 轻转退端子工具并保持塑胶卡扣处于打开状态，拉动对应线材直至退出塑孔。



TPA MUST BE ON ITS PRELOCK POSITION BEFORE CONTACT REMOVAL.  
在退端子前必须将 TPA 置于其预锁位置。



The dimension of releasing pin herein defined is for male terminals 0.64/1.2/2.8. However, it will be difficult to find the plastic connector latch and this tool may slip off of the latch. For female terminal release, the width (0.97) can increase to 1.5 and angle (58°) reduce to 30° for female terminals release.

如下尺寸是公端子 (0.64/1.2) 退出工具所需尺寸。当然此尺寸相对较小，不容易抵到塑胶卡扣处，也容易在操作过程中滑离卡扣位置。作为母端子 (0.64/1.2) 的退出工具，可以加大宽度 0.97 到 1.5，同时调小导引角度 58 度到 30 度。

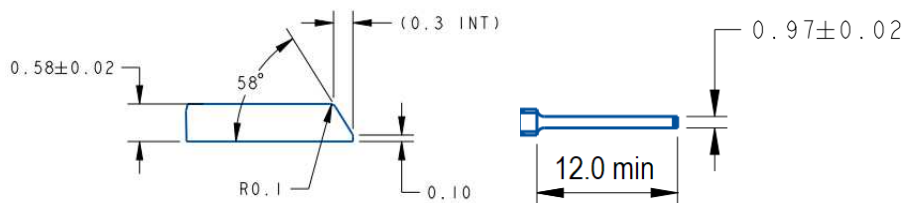

#### 6.2.2 1.20 Terminal Removal

#### 6.2.2 1.20 母端子退出

- A. Insert releasing pin along the terminal surface and till stop position as shown.  
A. 将退端子工具沿端子表面推至图示位置。

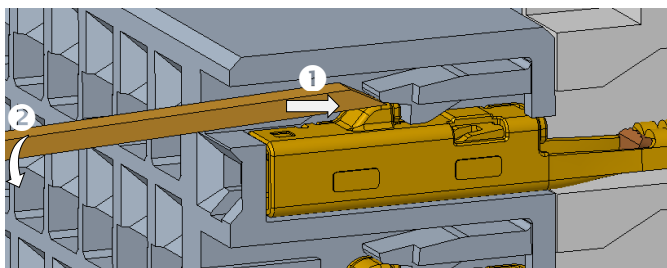

- B. pull and hold releasing pin and then pull the wire out of cavity.  
B. 轻抬退端子工具使塑胶卡扣处于打开状态并保持，再拉动对应的端子线束并退出塑孔。

### 6.2.3 2.80 Terminal Removal

#### 6.2.3 2.80 母端子退出

Ref to 6.2.1

参考 6.2.1 0.64 端子退出

## 7 TAB HOUSING DISASSEMBLY

### 7 公端连接器的拆装

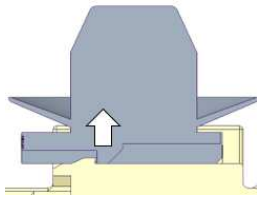

Clip structure is snap-fit type, contact clip vendor for release process.

卡扣槽结构采用的是搭扣卡扣结构，请联系对应卡扣供应商相关拆离步骤说明。

### 7.1 MALE TPA WITHDRAW

#### 7.1 公端 TPA 退回预锁位

- A. Insert the tool in one of the slots of central wall, and pull upward so that the TPA Slipping the end-lock position.  
A. 将工具伸到中间隔挡的槽中，轻推工具使 TPA 脱离终锁位置。

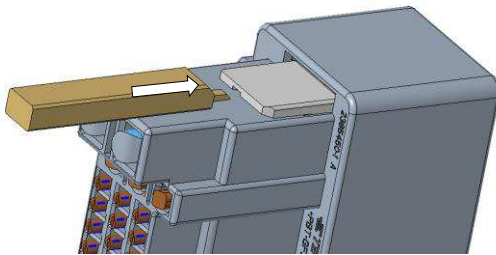

- B. Pull the tool until TPA reaches its pre-lock position, an audible click occurs.  
B. 拉动工具，直至 TPA 退到预锁位置，到位时有响声。



PLEASE DO NOT DAMAGE MALE TERMINALS DURING TPA REMOVAL.

退 TPA 时，需注意不能碰伤公端子。

### 7.2 MALE TERMINAL REMOVAL

#### 7.2 公端子退出

##### 7.2.1 0.64 Male Terminal Removal

##### 7.2.1 0.64 公端子退出

- A. Insert the tool along the terminal until it reaches the stop of housing lance.

A. 将退端子工具沿 TPA 上的孔伸入到塑胶挂钩处(图示红色虚线)

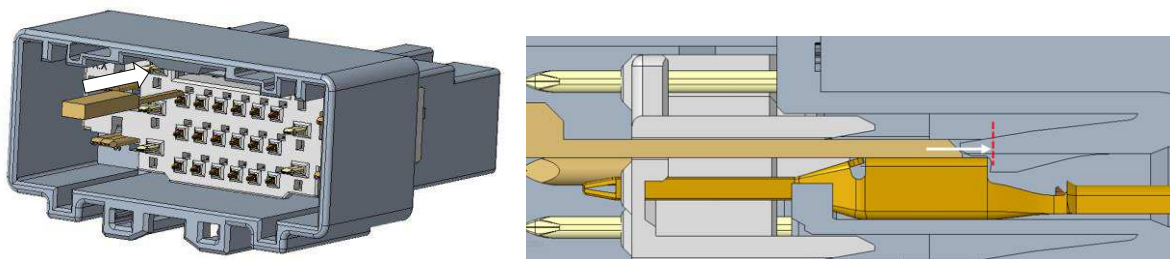

B. Rotate the tool and hold the tool, pull the wire until terminal out of cavity.

B. 轻微翘起工具，使塑胶卡钩完全脱钩，拉动对应的线材，直至端子完全退出塑孔。

**i** The dimension of releasing pin herein defined is miniature. It will be difficult to find the plastic connector latch and may slip off of the latch.

退出工具尺寸相对较小，操作中不容易抵到塑胶卡扣处，也容易在操作过程中滑离卡扣位置。

**i** It's possible to remove TPA out of housing and release terminal. When reassemble TPA, do not damage the terminals.

也可以将二次锁移除再进行退端子。重新组装 TPA 时需注意安装方法，切不可碰伤端子。

#### 7.2.2 1.20 Male Terminal Removal

##### 7.2.2 1.20 公端子退出

Ref to 7.2.1

参考 7.2.1 0.64 端子退出

#### 7.2.3 2.80 Male Terminal Removal

##### 7.2.3 2.80 公端子退出

Ref to 7.2.1

参考 7.2.1 0.64 端子退出