

## HCM250 Insert Series

### Table of contents

1. INTRODUCTION .....	2
2. SUPPORTING DOCUMENTS .....	2
2.1. Customer drawings.....	2
2.2. Product specification.....	2
2.3. Application Specification .....	2
2.4. Standards.....	2
3. DESCRIPTION .....	3
4. REQUIREMENTS.....	4
4.1. Wire selection and preparation .....	4
4.1.1. Stripping length L .....	4
4.1.2. Insulation diameter .....	4
4.2. Assemble wires to inserts .....	5
5. ASSEMBLY .....	7
5.1. Installing inserts to frame.....	7
5.2. Installing contacts to inserts .....	7
5.3. Contacts removal .....	8
6. STORAGE .....	8
6.1. Chemical exposure .....	8
6.2. Storage condition.....	8

## 1. INTRODUCTION

This specification contains the regulations for assembly of HCM250 contact inserts and the handling of these inserts.

## 2. SUPPORTING DOCUMENTS

### 2.1. Customer drawings

Please refer to the customer drawings of HCM250 insert series.

### 2.2. Product specification

The product specifications of the used articles are to be taken into account. The product specification describes the technical data as e.g. regulations, approvals, temperature range and rated voltage.

For further reference refer Product spec. 108-137171.

### 2.3. Application Specification

Connectors shall be assembled as below mentioned application specifications to ensure correct connector assembly.

### 2.4. Standards

- EN 61984: Connectors - Safety requirements and tests
- IEC 60664-1: Insulation coordination for equipment within low-voltage systems (Part 1)
- IEC 60999-1: Electrical copper conductors- Safety requirements for the clamping units for conductors

### 3. DESCRIPTION

This application specification describes the male insert and the female insert of the “HCM250” series. The listed terms are used in the specification in figure 1.

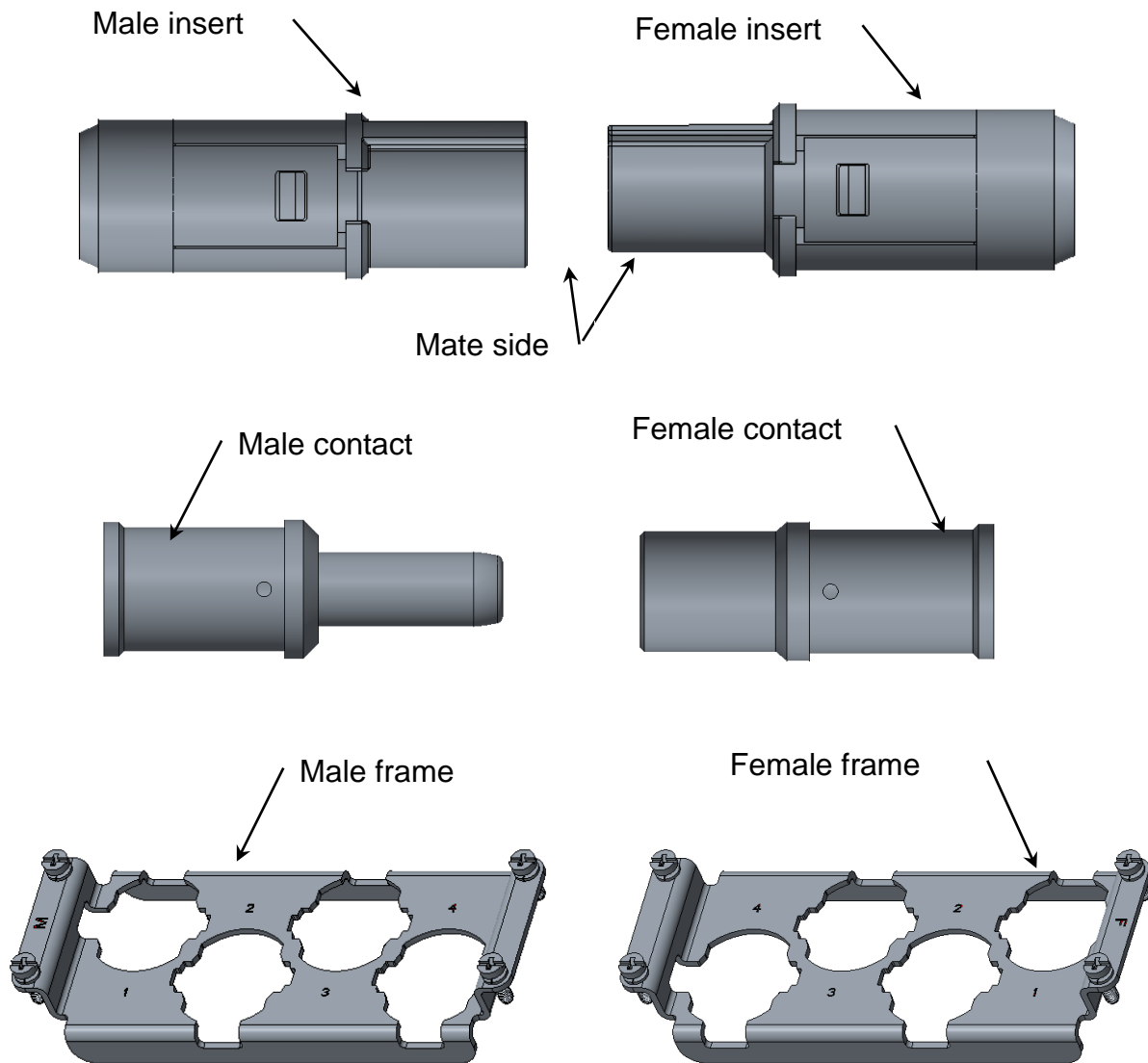

Figure: 1

## 4. REQUIREMENTS

### 4.1. Wire selection and preparation

#### 4.1.1. Stripping length L

Use proper tooling to strip the wire.

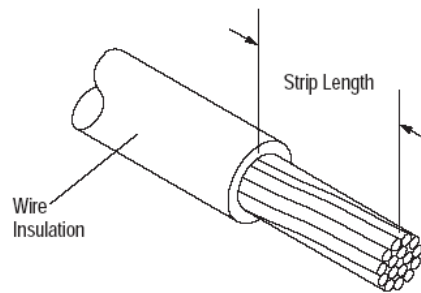

Figure: 2



When stripping the wire, care must be taken to avoid scraping, nicking, or cutting the conductor. Care must also be used when handling the wire during stripping to prevent cracking or breaking the conductor and insulation.

Depending upon the cross section of the wire or cable, the stripping length has to be selected from the table below. See Table 1.

Table: 1

Contact Insert	Max. Wire cross section		Strip Length For Reference L [mm]	Current /Voltage Rating
	[mm <sup>2</sup> ]	AWG		
HCM250-MC/FC	≤70 mm <sup>2</sup>	2/0	22	250A / 2000V

#### 4.1.2. Insulation diameter

Any wire that is used for the Electrical purpose is covered with insulating polymer. This insulation on the wires depends upon the wire size and type of application where it is being used. The insulation diameter for various wire sizes is as shown in table 2 only for reference.

Table: 2

Contact Insert	Max. Wire cross section		Insulation Diameter in (mm)
	[mm <sup>2</sup> ]	AWG	
HCM250-MC/FC	≤70 mm <sup>2</sup>	2/0	18



The Insulation diameter over the wire specified in the table 2 is for the insulation concentric, with equal thickness layer over the conducting wire.

## 4.2. Assemble wires to inserts

Assemble stripped wires to contacts (Crimp)

➤ Crimping tool

Crimping tool is available as below figure 3:

- Wire rage: 10-120mm<sup>2</sup>
- Name: Hydraulic crimper
- Order No.: T3100000015-000



Figure: 3

➤ Crimp

Insert the cable into the wire barrel of the contact. The wire strands must be visible in the reference hole of the contact. During the termination process make sure that the contact in the contact zone is not damaged or deformed.

When using manual crimp tools the following points must be followed:

- 1). Using the correct crimping dies for this type of contact. (Crimping dies are included in the crimping tool, for example: Using 70mm<sup>2</sup> crimping dies for 70mm<sup>2</sup> contact);
- 2). Installing the crimping dies into crimping tool.
- 3). Putting the contact and cable together into crimping dies.
- 4). Crimping the contact.

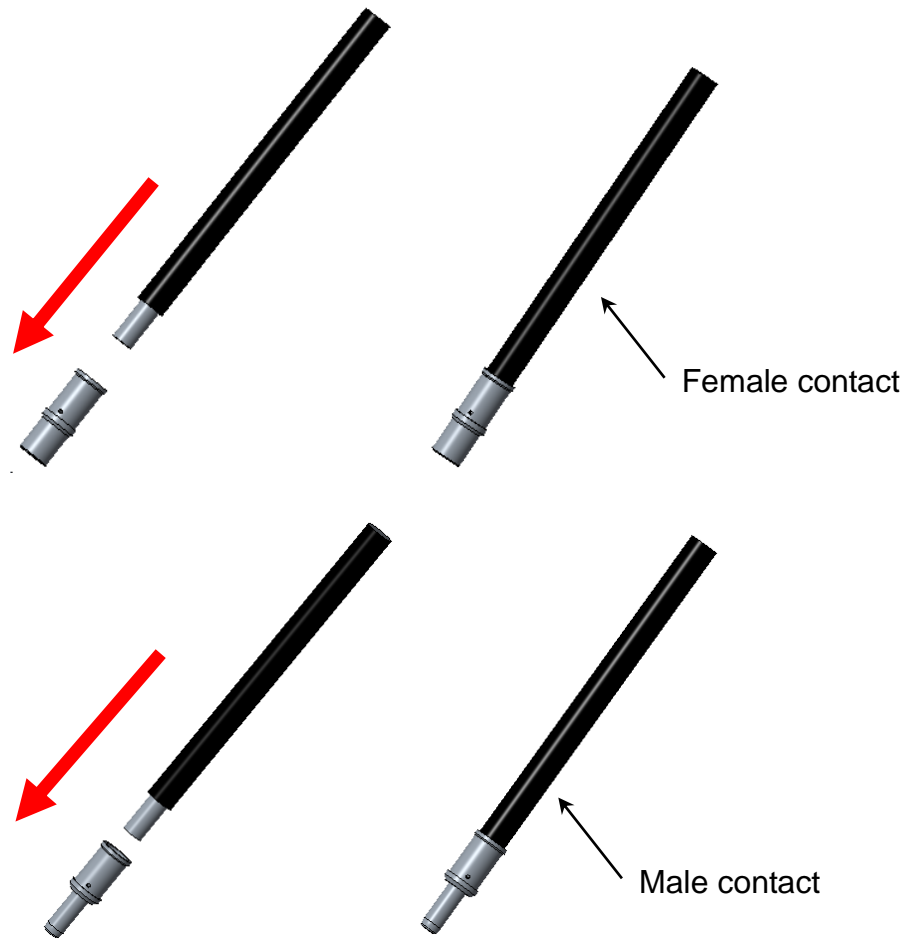

Figure: 4



NOTE For more detailed information, please refer to related contacts application specifications.

## 5. ASSEMBLY

With proper tools, assembling the male and female contact inserts to frames, then assemble them together into male and female connectors.

### 5.1. Installing inserts to frame

- 1) Inserting the male insert body or female insert body into frame ;
- 2) Installing insert cover in male insert or female insert, a click should be heard normally.

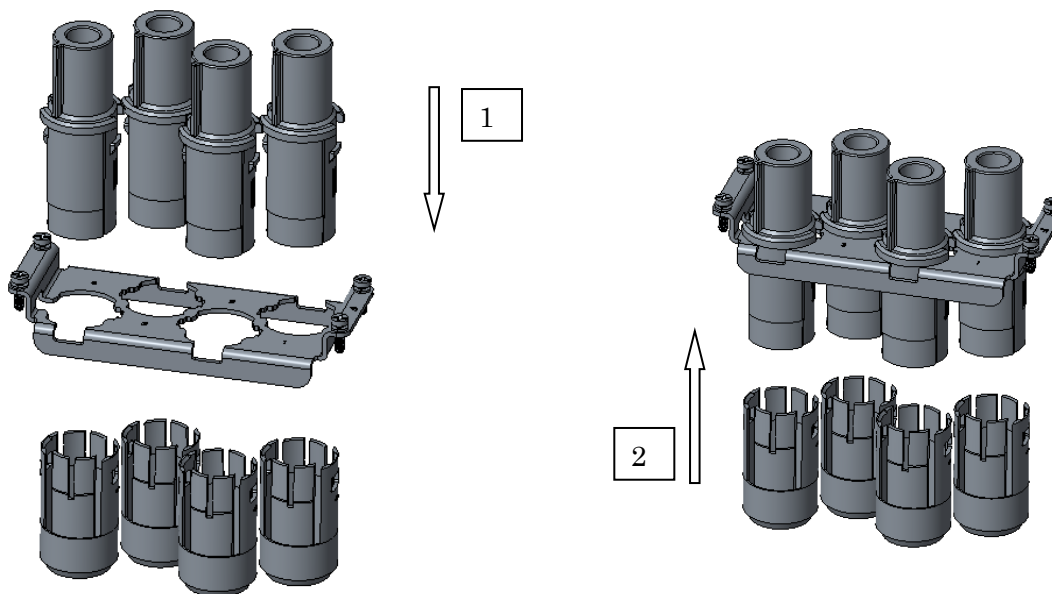

Figure: 5

### 5.2. Installing contacts to inserts

The crimped terminals are plugged into the insert by gently pushing it into the required position until the contact is locked by the inserts, a click should be heard normally.

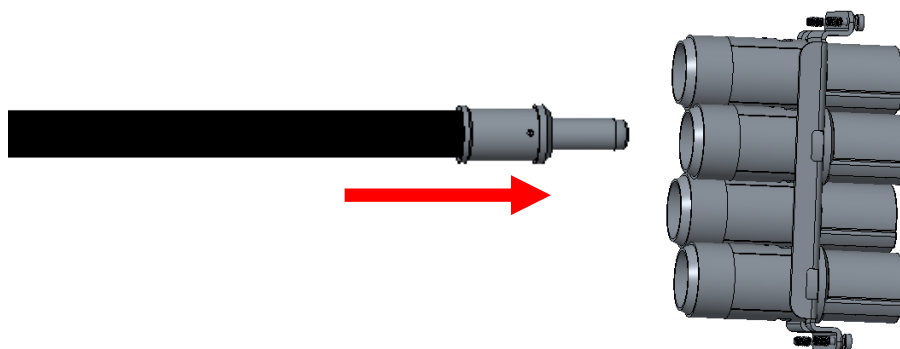

Figure: 6

## 5.3. Contacts removal

- 1) Insert the Flathead screwdriver along the crimped contact into the special space on the cover.
- 2) Now, pull out crimped contact holding cable and also the tool together to unplug the contact.

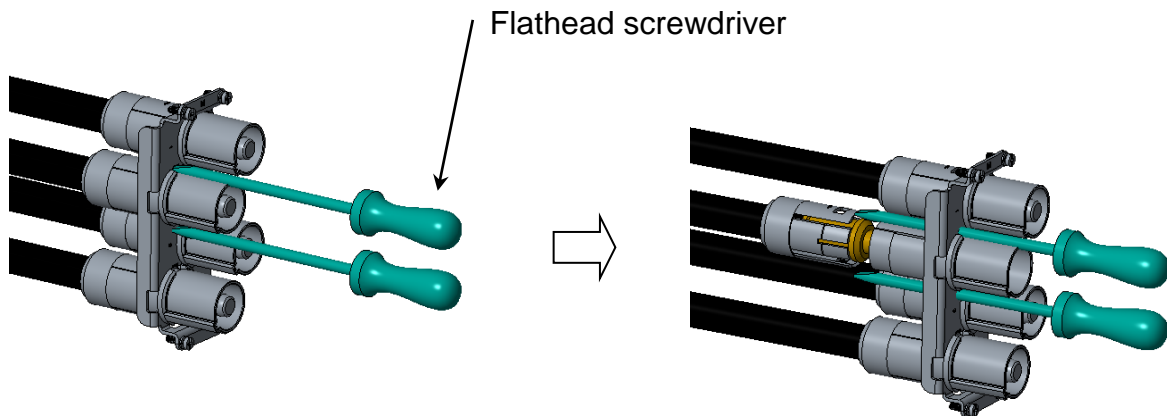

Figure: 7

## 6. STORAGE

### 6.1. Chemical exposure

Do not store the connectors near any chemical listed below as they may cause corrosion stress the connector contacts:

Alkalies, Ammonia, Citrates, Phosphates, Citrates, Sulfur, Amines, Carbonates, Nitrites, Sulfides, Nitrites, Tart rates.

### 6.2. Storage condition

The connectors should be stored in the air ventilation, no corrosive gas, no rain and no snow in the warehouse. Relative humidity: less than 85% RH. The connectors should remain in the shipping containers until ready for use to prevent deformation to the contacts. The connectors should be used on a first in, first out basis to avoid storage contamination that could adversely affect electrical functions.

-----END-----