



H8A IP65 Plastic Hood and Housing Series

Table of contents

- 1. INTRODUCTION2
- 2. SUPPORTING DOCUMENTS2
 - 2.1. Customer drawings.....2
 - 2.2. Product specification2
 - 2.3. Application Specification.....2
 - 2.4. Standards2
- 3. DESCRIPTION3
 - 3.1. Assembly product.....3
 - 3.2. Hood and housing types.....4
 - 3.2.1. Hood type4
 - 3.2.2. Housing type.....5
 - 3.2.2.1. Bulkhead mounted housing.....5
- 4. REQUIREMENTS.....6
 - 4.1. Panel cut-out6
- 5. ASSEMBLY.....6
 - 5.1. Assembly housing on panel.....6
 - 5.2. Assembly male/female insert into hood/housing.....7
 - 5.3. Assembly hood with housing7
- 6. STORAGE8

1. INTRODUCTION

This specification contains the regulations for assembly of various H8A IP65 plastic Hood and Housing.

The following components are available in this system:

Hood and housing: H8A.

2. SUPPORTING DOCUMENTS

2.1. Customer drawings

For dimensions and materials of the individual parts, please refer to the relative customer drawings of H8A.

2.2. Product specification

The product specifications of the used articles are to be taken into account. The product specification describes the technical data as regulations, temperature range and degree of protection. For further reference, please refer to product spec. 108-137137.

2.3. Application Specification

Connectors shall be assembled as below mentioned application specifications to ensure correct connector assembly.

2.4. Standards

- EN 61984: Connectors - Safety requirements and tests
- IEC 60664-1: Insulation coordination for equipment within low-voltage systems (Part 1)
- EN 60529: Degrees of Protection Provided by Enclosures (IP Code)
- EN 60068: Environmental testing

3. DESCRIPTION

3.1. Assembly product

The following picture (Figure 1) shows an example of complete assembly product.

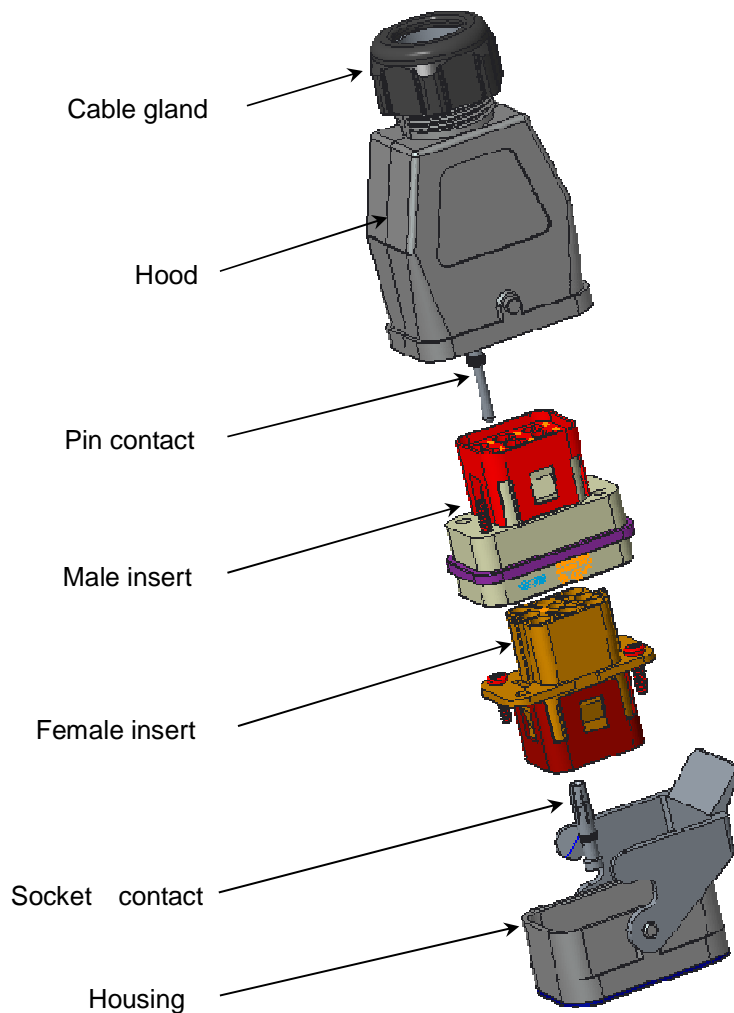

Figure: 1

The complete product consists of the following components (see figure 1):

- Cable gland
- Hood
- Pin contact
- Male insert
- Female insert
- Socket contact
- Housing

3.2. Hood and housing types

3.2.1. Hood type

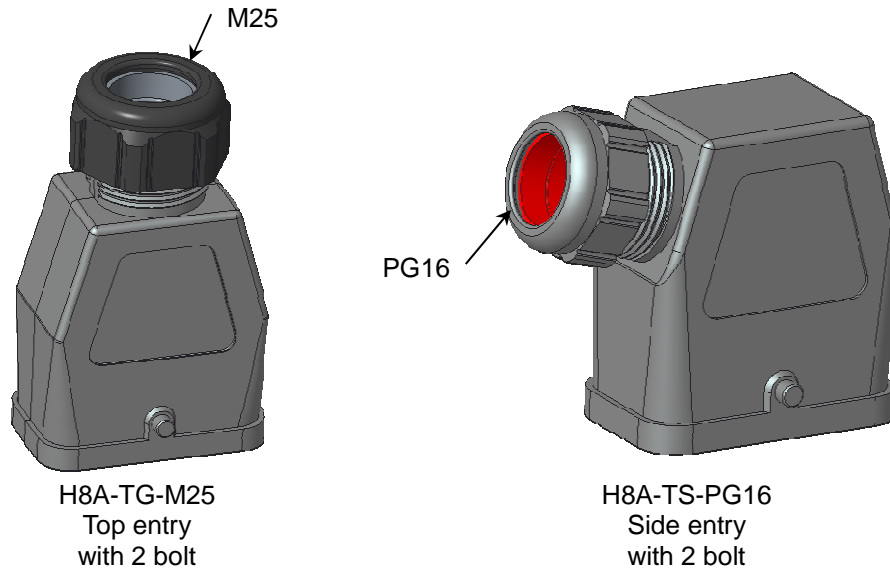
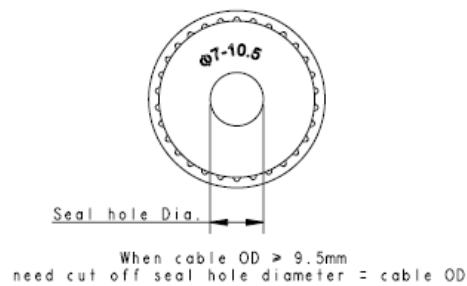

Figure: 2

Note: Different hood& housing size has different optional PG/M Thread. Refer to drawings for detailed information.

There are 3 type for “H8A-TG-M25 Top entry with 2 bolt” as below shown:

3.2.1.1 H8A-TG-M25,Dia.7-10.5: When cable OD $\geq \Phi 9.5\text{mm}$, need cut off the seal hole diameter as below:



3.2.1.2 H8A-TG-M25,Dia.10.5-14: When cable OD $\geq \Phi 13\text{mm}$, need cut off the seal hole diameter as below:

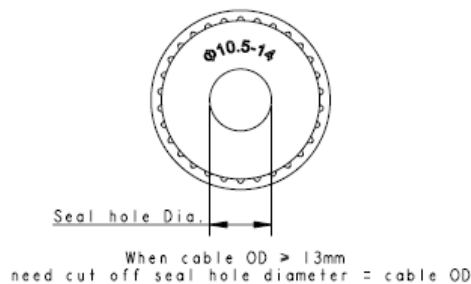

3.2.1.3 H8A-TG-M25, Dia.14-17: When cable OD $\geq \Phi 16\text{mm}$, need cut off the seal hole diameter as below:

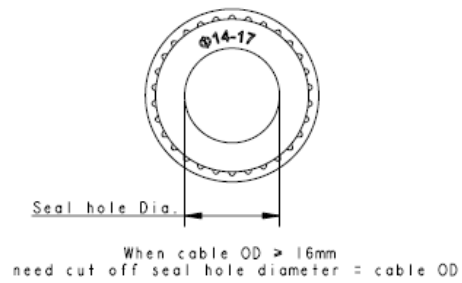

3.2.2. Housing type

3.2.2.1. Bulkhead mounted housing

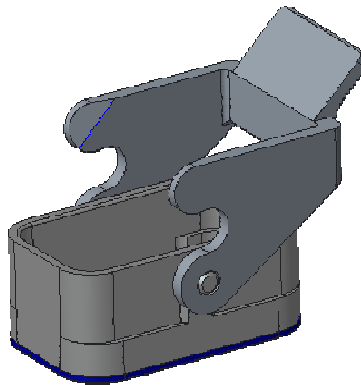

H8A-AG
Bottom entry
with 1 level locking

Figure: 3

4. REQUIREMENTS

4.1. Panel cut-out

For bulkhead mounted housings, for example as shown in Figure 4.

More detailed information also can be found from related customer drawings.

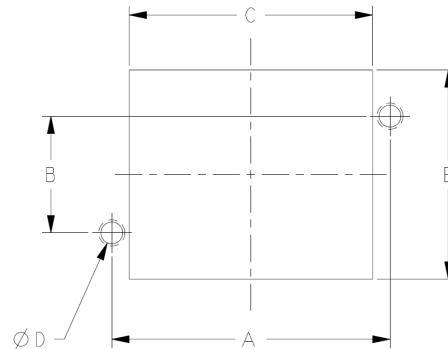

Figure: 4

Size	Dimension(mm)				
	A	B	C	E	D
H8A	32.2	13.4	26.9	22.7	For M3 screw

5. ASSEMBLY

5.1. Assembly housing on panel

For bulkhead mounted housings, fix housing with 2 x M3 screws. Tightening torque refer to spec of screws, but no less than 0.5Nm. For example as shown in Figure 5.

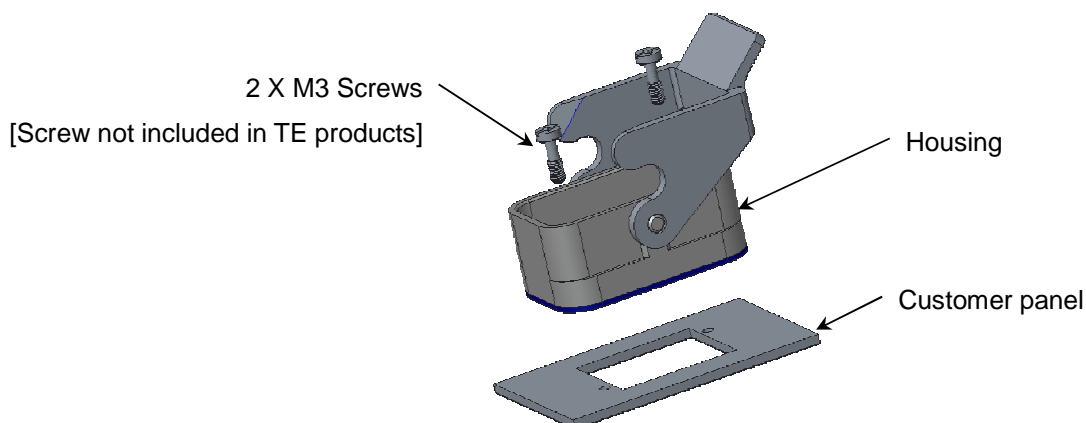

Figure: 5

5.2. Assembly male/female insert into hood/housing

The inserts are fixed into the hood/housing with 2 x ST2.9 self-tapping screw. And these ST 2.9 self-tapping screws are components on inserts. Tightening torque refer to spec of insert drawing.

For example as shown in Figure 6.

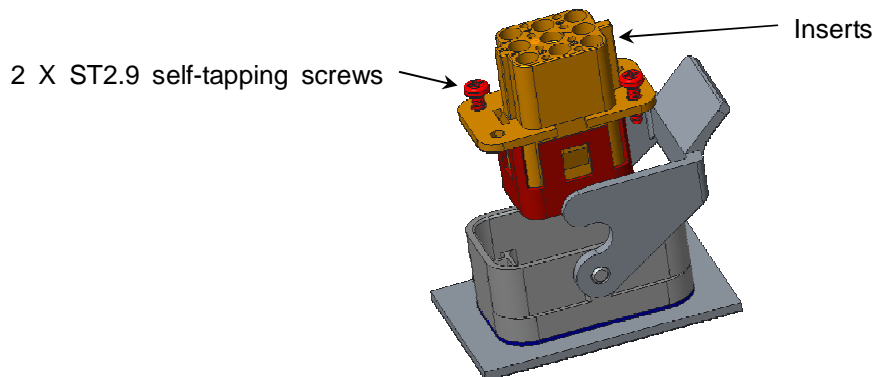

Figure: 6

Note:

- Refer application spec of male/female insert separately and before fixing to hood/housing, male/female insert should be well prepared.
- Whatever the type of hood/housing or the type of male/female insert, they have same assembly process here.

5.3. Assembly hood with housing

A complete locking system with locking consists of the following components, for example as shown in Figure 7. The locking is used for the locking of the housing and hood. The locking is fixed on the housing and have to be pushed up to lock the hood.

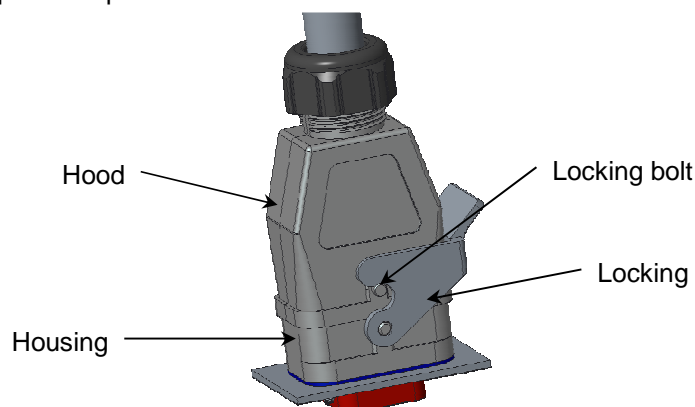

Figure: 7

Note:

- Whatever the type of hood & housing, they have same assembly process here.

6. STORAGE

The connectors should be stored in the air ventilation, no corrosive gas, no rain and no snow in the warehouse. Relative humidity: less than 85% RH.

NOTE



Any conflict is found between this file and customer drawings, customer drawings are preferential.

And please contact TE Connectivity related engineer if necessary.

----- End -----