

NOTE



All numerical values are in metric units [with U.S. customary units in brackets]. Dimensions are in millimeters. Unless otherwise specified, dimensions have a tolerance of ± 0.13 and angles have a tolerance of $\pm 2^\circ$. Figures and illustrations are for identification only and are not drawn to scale.

1. INTRODUCTION

This specification covers the requirements for application of SMT Poke-In Connectors for use on printed circuit (pc) board based LED strip lighting. The connector accommodates 18, 20, or 22 AWG solid copper wires; or 18 and 20 AWG prebond copper wires; or 18 AWG stranded copper wires.

The low profile housing with flat top surface allows for vacuum pick-and-place application. The connector is packaged in tape and reel packaging per EIA-481.

When corresponding with TE Connectivity Personnel, use the terminology provided in this specification to facilitate your inquiries for information. Basic terms and features of this product are provided in Figure 1.

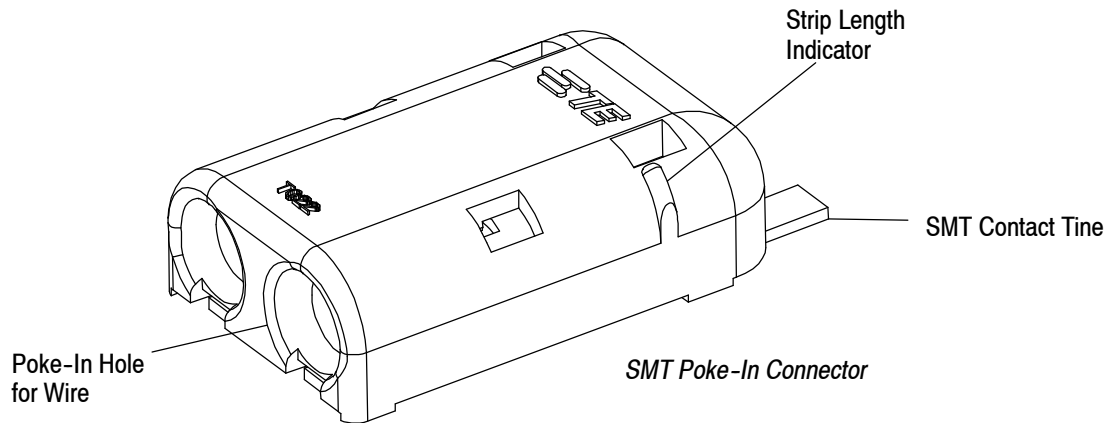

Figure 1

2. REFERENCE MATERIAL

2.1. Revision Summary

- Initial release of document

2.2. Customer Assistance

Reference base part number 2154662 and product code L012 are representative of the SMT Poke-In Connectors. Use of these numbers will identify the product line and expedite your inquiries through a service network established to help you obtain product and tooling information. Such information can be obtained through a local TE Representative or, after purchase, by calling Product Information at the number at the bottom of this page.

2.3. Drawings

Customer drawings for product part numbers are available from the service network. If there is a conflict between the information contained in the customer drawings and this specification or with any other technical documentation supplied, call the Product Information number at the bottom of this page.

2.4. Manuals

Manual 402-40 is available from the service network. This manual provides information on various flux types and characteristics along with the commercial designation and flux removal procedures. A checklist is included in the manual as required for information on soldering problems.

2.5. Specifications

Product Specification 108-2284 provides product performance and test information for the Poke-In Connector. Workmanship Specification IPC-A-610 provides solderability requirements and evaluation methods.

3. REQUIREMENTS

3.1. Safety

Do not stack product shipping containers so high that the containers buckle or deform.

3.2. Limitations

The connectors are designed to operate in a temperature range of -40° to 105°C [-40° to 221°F]

3.3. Material

The housing is made of UL 94V-0 rated thermoplastic. The contacts are made of phosphorous bronze, under-plated with nickel, and plated overall with tin.

3.4. Storage

A. Shelf Life

The connectors should remain in the shipping containers until ready for use to prevent deformation. The connectors should be used on a first in, first out basis to avoid storage contamination that could adversely affect performance.

B. Chemical Exposure

Do not store connectors near any chemical listed below as they may cause stress corrosion cracking in the contacts.

Alkalies	Ammonia	Citrates	Phosphates	Citrates	Sulfur Compounds
Amines	Carbonates	Nitrites	Sulfur Nitrites		Tartrates

3.5. Wire Selection and Preparation

These connectors will accept 18, 20, and 22 AWG solid copper wire; 18 and 20 AWG prebond copper wire; and 18 AWG stranded copper wire. The table in Figure 2 provides wire selection for the Poke-In Connectors. The wire strip length is 9.00 ±1.00 mm for the poke-in cavity with an insulation diameter of ≤2.10 mm. See Figure 3.

RECOMMENDED WIRE		
18 AWG	UL 1007-18	Solid
18 AWG	UL 1007-18 (16)	Prebond
18 AWG	UL 1007-18 (16)	Stranded
20 AWG	UL 1007-20	Solid
20 AWG	UL 1007-20 (7)	Prebond
22 AWG	UL 1007-22	Solid

Figure 2

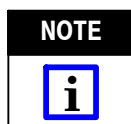

If stranded wire is used, it must be 16 strands, if prebond wire is used, the strand count must be 16 strands or less.

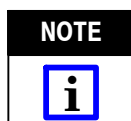

When preparing stranded wire, it is recommended NOT to twist strands after stripping the insulation. The stranded wire will insert best if the strands are straight (or slightly twisted) as the wire is manufactured.

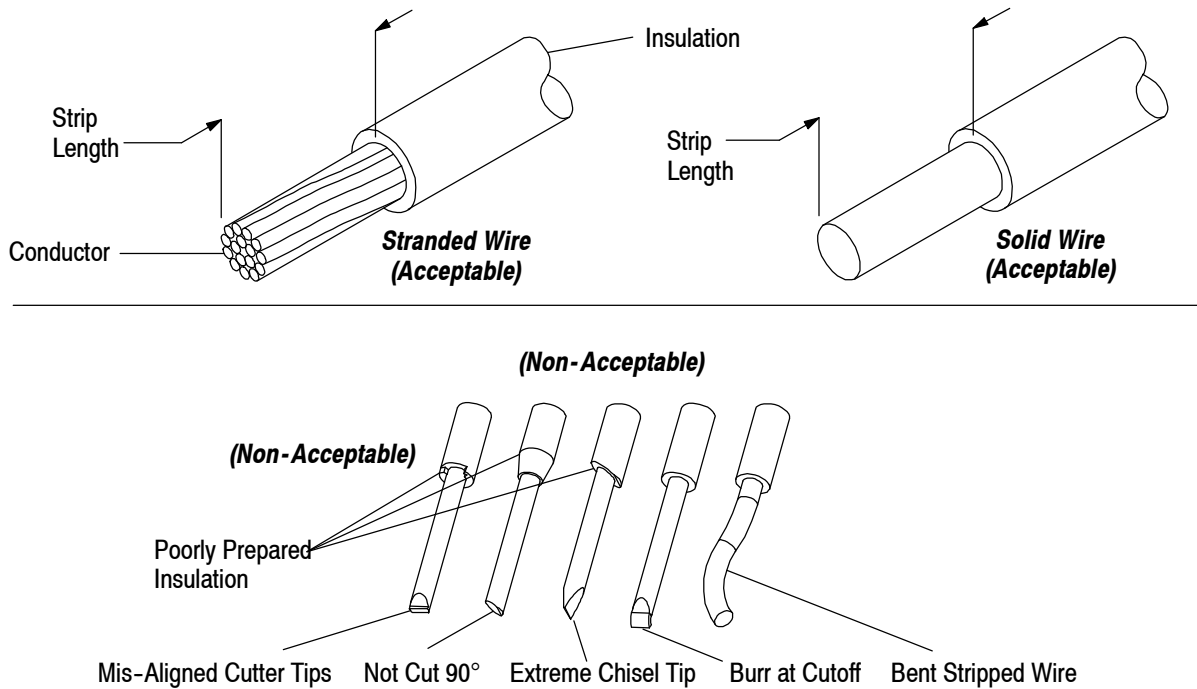

Figure 3

A. Workmanship



The housing must not be damaged in any way. There shall be no bending of the contacts. There shall be no exposed copper wire or broken or bent conductor strands.

B. Conductor Insertion

All wires must be pushed firmly inside the contact wire openings. The wires must be fully inserted so that the wire insulation is inserted into and surrounded by the end of the housing.

C. Wire Termination Depth

The required wire termination depth is achieved when the wire, with insulation stripped to 9.00 ± 1.00 mm, has bottomed in the connector housing.

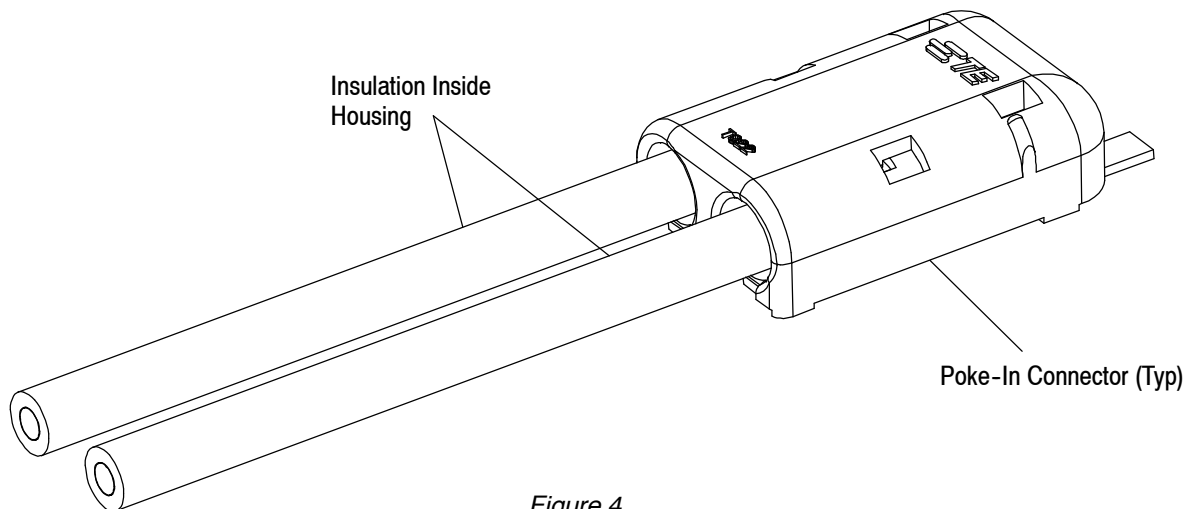

Figure 4

3.6. Strain Relief

It is recommended that a means be provided to support the wire bundle extending away from the connector to prevent inadvertent application of high force to the wire bundle from transmitting into the wire/connector interface. When the wire/connector interface is expected to be exposed to a force greater than 22 N [5.0 lbs], an external strain relief is recommended. An external strain relief is also recommended for 18 AWG 16-stranded wire. The suggested strain relief method is to use a cable tie and anchor. Refer to Figure 5.

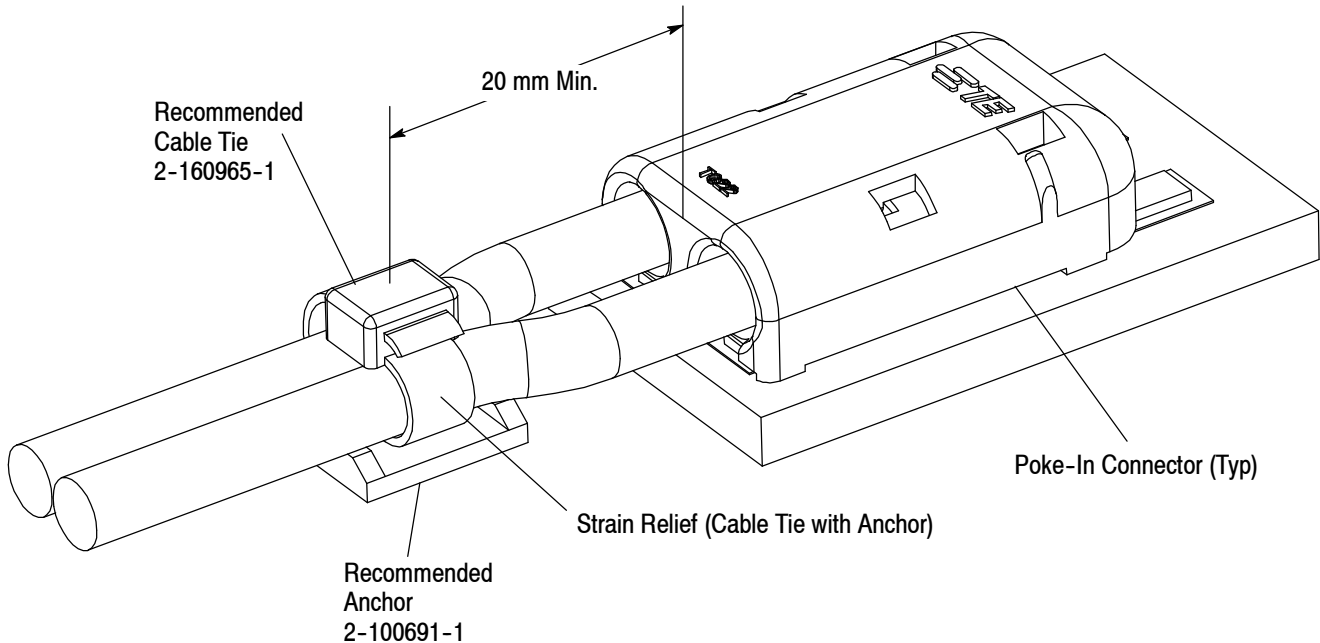

Figure 5

3.7. PC Board

A. Material and Thickness

Common pc board materials may be used such as glass epoxy (FR-4 or G-10), Aluminum-clad pc boards and flex circuits. The pc board thickness may vary to suit the end use thickness.

B. Tolerance

Maximum allowable bow of the pc board shall be 0.10 mm over the length of the connector.



Since the connector housings may rest on top of the solder mask, an excessively high mask will allow too much space between the solder tine and pad for a good solder joint. A solder joint under these conditions would be weak, and would not provide long-term performance for the connector.

C. Pads

The pc board circuit pads must be solderable in accordance with IPC J-STD-003.

D. Layout

The pc board layout must be designed using the dimensions provided on the customer drawing for the specific connector. The recommended pc board layout is shown in Figure 6.

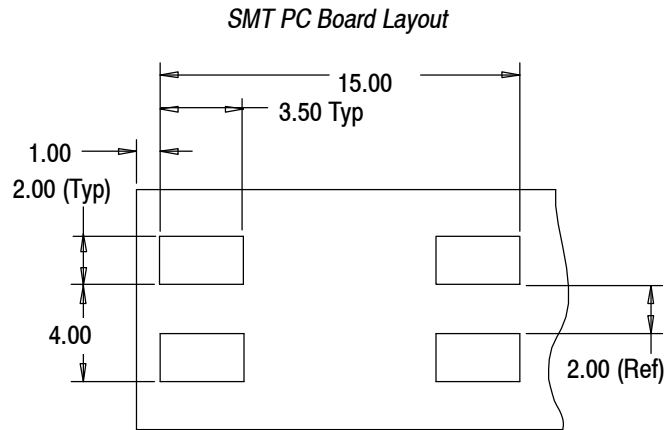

Figure 6

3.8. Spacing

The connector is able to be placed side-by-side on the pc board when pads are placed on 4.0 mm centers. See Figure 7.



Connectors should be handled only by the housing to avoid deformation, contamination, or damage to the contact tines.

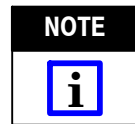

Two-position shown, one-position dimensions are the same.

SMT Poke-In Connector

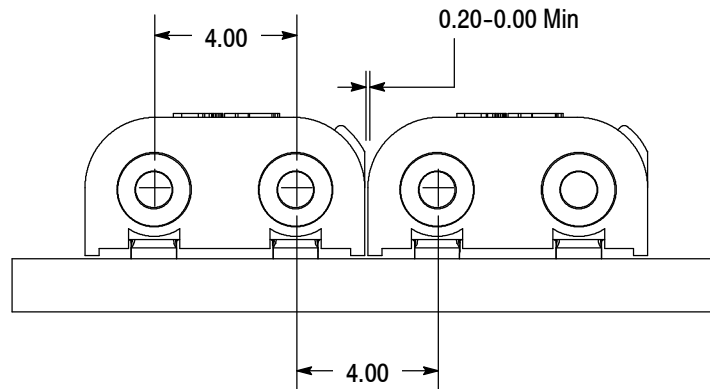

Figure 7

3.9. Connector Placement for SMT Connectors

This product is packaged in tape and reel packaging per EIA-481. Robotic/gripper placement requires total equipment accuracy of 0.13 mm to locate the connector for insertion. This includes gripper and fixture tolerances, as well as equipment repeatability. Insertion location will be programmed by a simple pantograph/template system or software package. Optimally, the contact solder tines should be centered on the pc board pads. However, slight misalignment is permissible for the performance classifications specified in Association of Connecting Electronics Industries IPC J-STD-001, "Requirements for Soldering Electrical and Electronic Assemblies." See Figure 8.

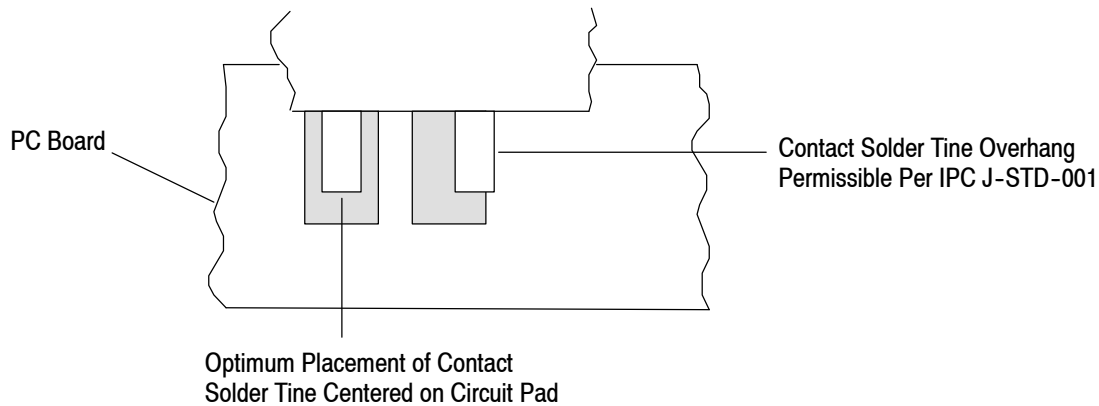

Figure 8

3.10. Soldering

Observe guidelines and procedures when soldering contacts. Solder, clean, and dry all leads to contacts according to the following. The connectors should be soldered using vapor phase reflow (VPR), double-sided, non-focused infrared (IR), forced air convection, or equivalent soldering techniques. All solder joints should conform to the Workmanship Specification IPC-A-610 and IPC J-STD-001.

A. Flux Selection

Contacts must be fluxed prior to soldering with a mildly active, rosin base flux. Selection of the flux will depend on the type of pc board and other components mounted on the board. Additionally, the flux must be compatible with the wave solder line, manufacturing, health, and safety requirements. Flux that is compatible with the connectors is provided in Figure 9.

FLUX TYPE	ACTIVITY	RESIDUE	COMMERCIAL DESIGNATION	
			KESTER	ALPHA
Type RMA (Mildly Activated)	Mild	Noncorrosive	185/197	611

Figure 9

B. Connectors with SMT Contacts

1. Solderability

The pc board pads must be solderable in accordance with Test Specification IPC/EIA J-STD-003 and all other requirements for surface mount contacts specified in this document.

2. Solder Paste Characteristics

- a. Alloy type shall be SAC 305; Sn 96.5/Ag 3.0/Cu 0.5
- b. Flux incorporated in the paste shall be rosin, mildly active (RMA) type.
- c. Paste will be at least 80% solids by volume.
- d. Mesh designation -200 to +325 (74 to 44 square micron openings, respectively).
- e. Minimum viscosity of screen print shall be $5 \times 10\%$ cp (centipoise).
- f. Minimum viscosity of stencil print shall be $7.5 \times 10\%$ cp (centipoise).

3. Solder Volume

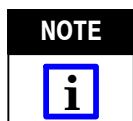

Solder paste volumes are required as follows (calculated per 50% solids content). Paste volume may vary depending on the composition.

KESTER and ALPHA are trademarks.

Solder volume for each SMT Poke-In Connector must be according to the following:

1.75 mm³ per contact solder tine

4. Stencil

The stencil aperture shall be determined by the circuit pad size and stencil thickness. It may be any shape as long as it prevents solder bridging from one pad to another. Generally, the thinner stencil will need a larger aperture to maintain the given volume of solder paste. See Figure 10.

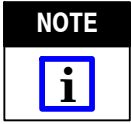

The stencil layouts illustrated apply to the top (connector) side (unless otherwise noted) of the pc board. For any other variations, refer to the pc board mounting configurations on the appropriate customer drawing to determine modifications necessary to the solder stencils in Figure 10.



All traces must be covered by solder mask in the solder deposit area. Exposed traces could cause bridging and create a short, or wick solder away from the solder tines, producing a weak solder joint.



If a hold-down aperture is required other than that specified, the design must ensure that the connector housing will not sit on the solder deposit.

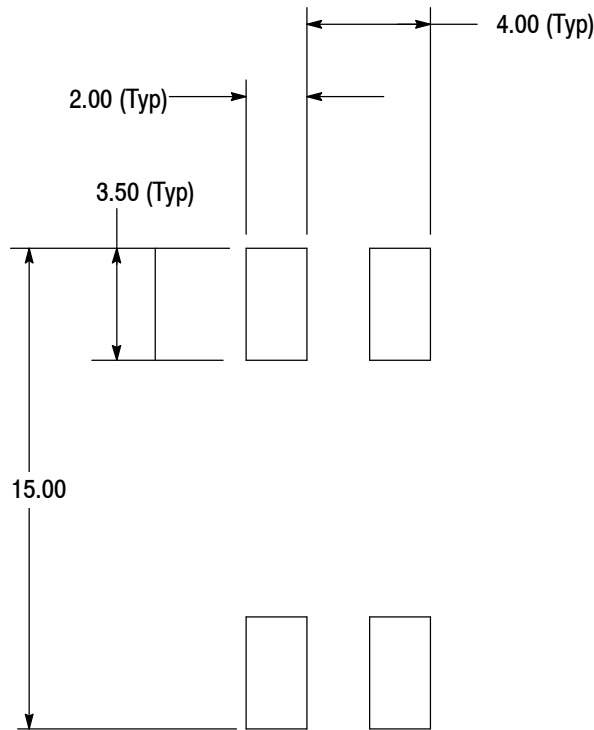

Figure 10

5. Solder Mask

Solder mask is recommended between all pads when soldering connectors with surface mount contacts to minimize solder bridging between pads. The mask must not exceed the height of the pad by more than 0.05 mm. If a trace is run between adjacent pads on the solder side of the pc board, a solder mask must be applied over the trace to prevent bridging and wicking of solder away from the contact solder tines. Those most suitable are Liquid Photo Imageable and Dry Film.



Since the connector may rest on top of the solder mask, an excessively high mask will allow too much space between the lead and pad for a good solder joint. A solder joint under these conditions would be weak and would not provide long-term performance for the connector.

6. Process

Connectors with surface mount contacts should be soldered using vapor phase (VPR), double-sided, non-focused infrared reflow (IR) or equivalent soldering techniques. Due to many variables involved with the reflow process (i.e., component density, orientation, etc.), it is recommended that trial runs be conducted under actual manufacturing conditions to ensure product and process compatibility. These connectors will withstand the temperature and exposure time specified in Figure 11.

SOLDERING PROCESS	TEMPERATURE (Max)	TIME (At Max Temperature)
IR	220°C [428°F]	3 Minutes

Figure 11

The lead-free reflow profile is shown in Figure 12.

Kester Lead-Free Reflow Profile
Alloys: Sn96.5/Ag3.0/Cu0.5 and Sn96.5/Ag3.5

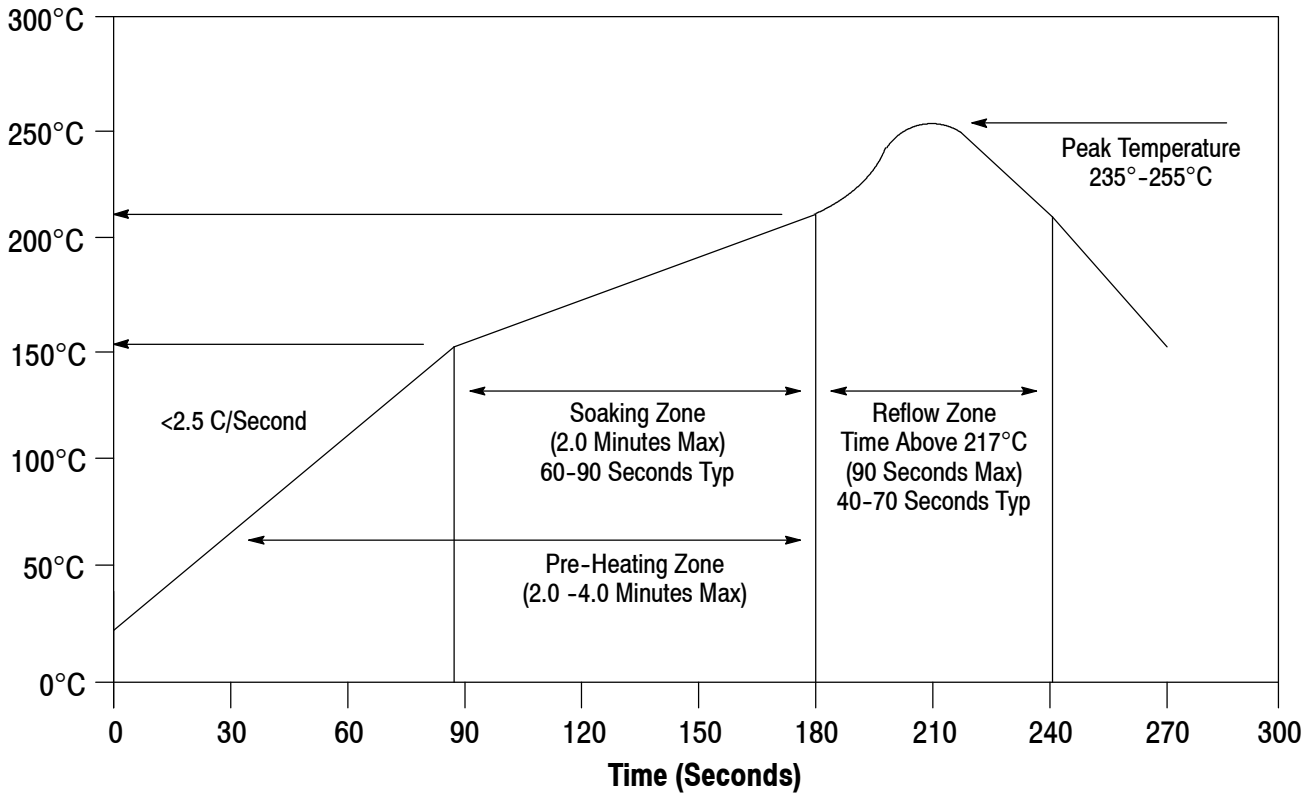

Figure 12

C. Cleaning

After soldering, removal of fluxes, residues, and activators is necessary. Consult with the supplier of the solder and flux for recommended cleaning solvents. Common cleaning solvents that will not affect the connectors or assemblies for the times and temperatures provided without any adverse effects on the connector assembly are listed in Figure 13.



Consideration must be given to toxicity and other safety requirements recommended by the solvent manufacturer. Trichloroethylene and Methylene Chloride can be used with no harmful affect to the connectors; however, TE does not recommend them because of the harmful occupational and environmental effects. Both are carcinogenic (cancer-causing) and Trichloroethylene is harmful to the earth's ozone layer.



If you have a particular solvent that is not listed, contact TE Tooling Assistance Center or Product Information at the number on the bottom of page 1.

CLEANER		TIME (Minutes)	TEMPERATURES (Maximum)	
NAME	TYPE		CELSIUS	FAHRENHEIT
ALPHA 2110	Aqueous	1	132	270
BIOACT EC-7	Solvent	5	100	212
BUTYL CARBITOL	Solvent	1	Room Ambient	
Isopropyl Alcohol	Solvent	5	100	212
KESTER 5778	Aqueous	5	100	212
KESTER 5779	Aqueous	5	100	212
LONCOTERGE 520	Aqueous	5	100	212
LONCOTERGE 530	Aqueous	5	100	212
Terpene Solvent	Solvent	5	100	212

ALPHA, BIOACT, CARBITOL, KESTER, AND LONCOTERGE are trademarks.

Figure 13

D. Drying



Excessive temperatures may cause housing and plating degradation.

When drying cleaned assemblies and pc boards, temperatures to which the connectors are subject should not exceed 220°C [492°F] for more than 3 minutes.

3.11. Checking Installed Connector

All solder joints should comply with TE Workmanship Specification 101-21. For typical fillets for surface mount and through-hole time requirements, refer to Figure 14.



Connectors or pc boards should not be tested by the insertion of probes of any type into the contact wire openings. This will result in damage to the contacts. Poke-in contacts are designed for a single wire insertion, of the gage and type listed in Section 3.5.

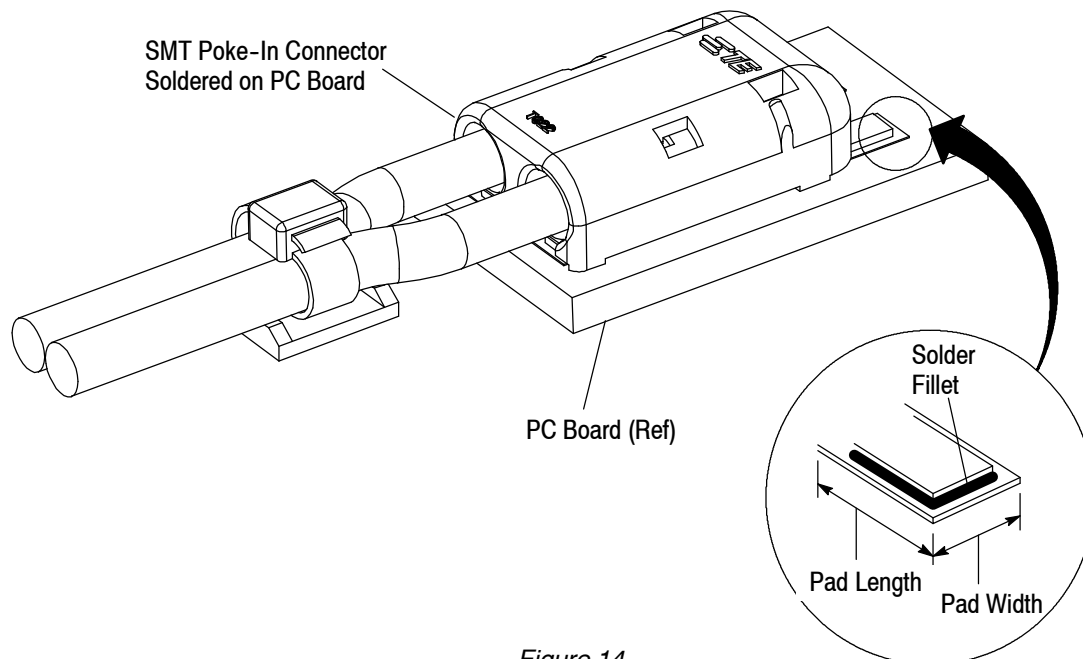

Figure 14

3.12. Replacement and Repair

The contacts and housings are not repairable. DO NOT use damaged or defective contacts or housings. DO NOT remove the wire and re-terminate contacts.

4. QUALIFICATIONS

Poke-In Connectors are Component Recognized by Underwriters Laboratories, Inc. in File E28476, Volume 39, and have been Investigated to CSA International by UL.

5. TOOLING

5.1. Robotic Equipment

The robotic equipment must have a true position accuracy tolerance of 0.25 mm to properly locate the connectors. This includes gripper and fixture tolerances as well as equipment repeatability.

NOTE

Automatic machine placement is recommended for connectors instead of manual placement with surface mount contacts.

5.2. PC Board Support

For automatic machine placement, a pc board support must be used to prevent bowing of the pc board during the placement of connectors. It should have flat surfaces with holes or a channel large enough and deep enough to receive any protruding components. The pc board support must be customer made.

6. VISUAL AID

Figure 15 shows a typical application of Poke-in Connector. This illustration should be used by production personnel to ensure a correctly applied product. Applications which DO NOT appear correct should be inspected using the information in the preceding pages of this specification and in the instructional material shipped with the product or tooling.

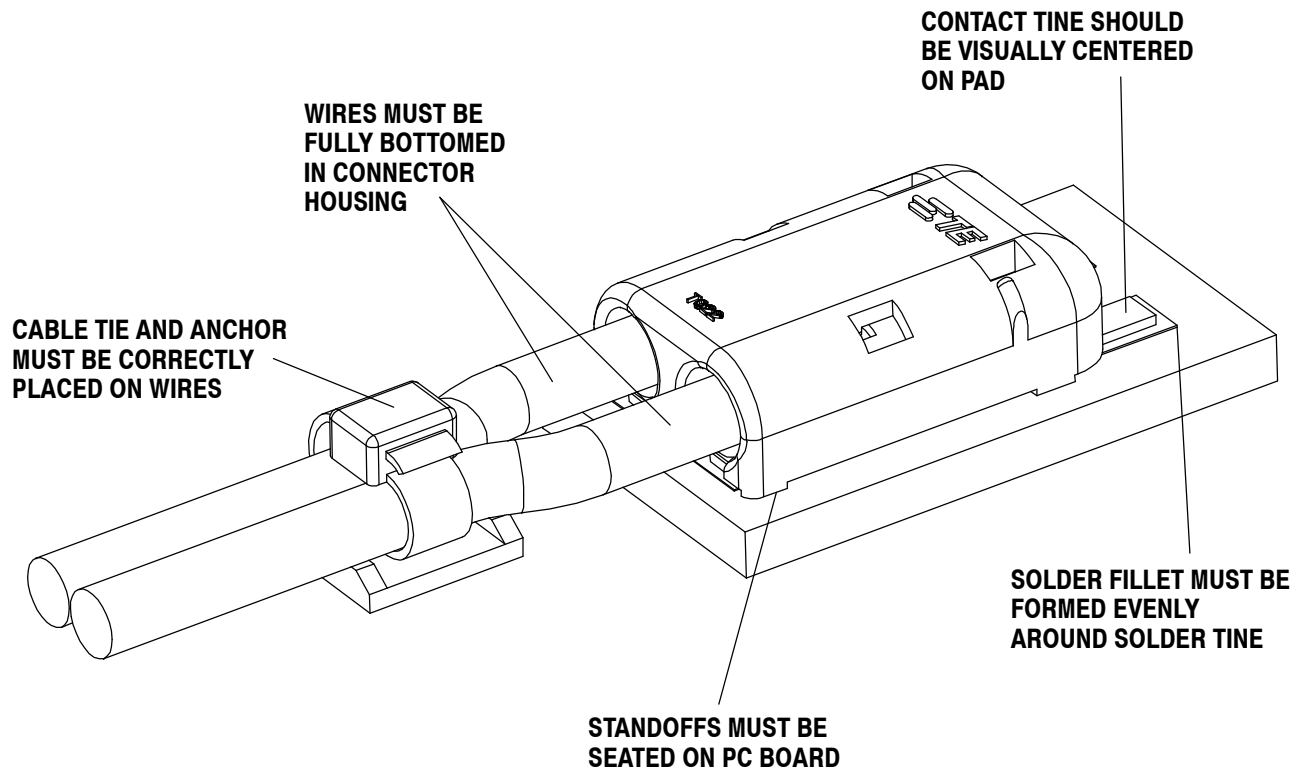

FIGURE 15. VISUAL AID