

**NOTE**

All numerical values are in metric units [with U.S. customary units in brackets]. Dimensions are in millimeters [and inches]. Unless otherwise specified, dimensions have a tolerance of ± 0.13 [$\pm .005$] and angles have a tolerance of $\pm 2^\circ$. Figures and illustrations are for identification only and are not drawn to scale.

1. INTRODUCTION

This specification covers the requirements for application of Miniature AMP-IN contacts.

Basic terms and features of this product are provided in Figure 1.

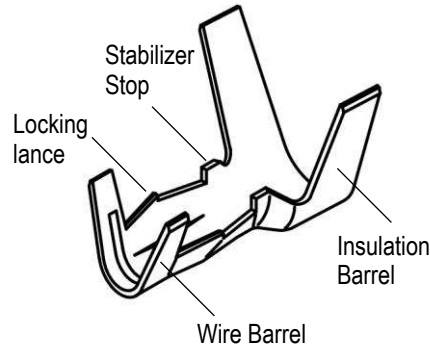

Figure 1

2. REFERENCE MATERIAL

2.1. Revision Summary

Initial release of application specification.

2.2. Customer Assistance

Reference Product Base Part Number 2393237,2393227,2393222,2393199,2393261 and Product Code 1326 are representative of Miniature AMP-IN contacts. Use of these numbers will identify the product line and help you to obtain product and tooling information when visiting www.te.com or calling the number at the bottom of page 1.

2.3. Drawings

Customer drawings for product part numbers are available from www.te.com. Information contained in the customer drawing takes priority.

2.4. Manuals

Manual 402-40 can be used as a guide to soldering. This manual provides information on various flux types and characteristics with the commercial designation, flux removal procedures, and a checklist for information on soldering problems.

2.5. Specifications

Product Specification 108-106642 provides product performance and test results.

2.6. Instructional Material

Instruction sheets (408-series) provide product assembly instructions or tooling setup and operation procedures. Instructional material that pertain to this product are:

- 408-8040 Heavy Duty Miniature Quick-Change Applicators with Mechanical Feed System
- 408-9640 Crimp Quality Monitor (CQM) Applicators for Side-Feed and End-Feed Applications
- 408-10389 Ocean Side-Feed Applicators

3. REQUIREMENTS

3.1. Safety

Do not stack product shipping containers so high that the containers buckle or deform.

3.2. Storage

A. Ultraviolet Light

Prolonged exposure to ultraviolet light may deteriorate the chemical composition used in the product material.

B. Shelf Life

The product should remain in the shipping containers until ready for use to prevent deformation to components. The product should be used on a first in, first out basis to avoid storage contamination that could adversely affect performance.

C. Chemical Exposure

Do not store product near any chemical listed below as they may cause stress corrosion cracking in the material.

Alkalies	Ammonia	Citrates	Phosphates	Citrates	Sulfur Compounds
Amines	Carbonates	Nitrites	Sulfur Nitrites		Tartrates



NOTE

Where the above environmental conditions exist, phosphor-bronze contacts are recommended instead of brass if available.

3.3. Wire Selection and Preparation

The contacts accept 1 stranded copper wire sizes 0.14 to 3.29 mm² [26 AWG to 12 AWG] with an insulation diameter range of 1.02 to 4.2 mm. Each wire must be stripped to the dimensions given in Figure 2.



CAUTION

Care must be taken not to nick, scrape, or cut any part of the wire during the stripping operation.

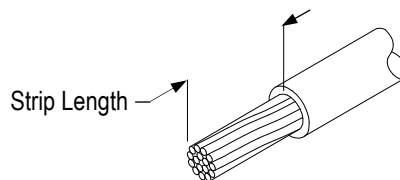

Contact		Wire	
Part Number	Wire Size (mm ²)[AWG]	Insulation Diameter(mm)	Strip Length(mm)
2393237	3.29 [12]	4.0~4.2	6.50 ± 0.20
2393227	2.08 [14]	3.4~3.8	6.40 ± 0.20
2393222	0.85~1.32 [18~16]	2.8~3.4	6.25 ± 0.25
2393199	0.34~0.85 [22~18]	1.5~3.0	5.50 ± 0.25
2393261	0.14~0.34 [26~22]	1.02~2.5	5.50 ± 0.25

Figure 2

3.4. Contact Crimping

The contacts must be crimped according to the instructions packaged with the machine.



CAUTION

Care shall be taken to ensure that the wire insulation is not cut or broken during the crimping operation.

A. Cutoff Tab

The cutoff tab is the remaining portion of the carrier strip after the contact is cut from the strip. It must not exceed the dimension given in Figure 3.

B. Wire Barrel Crimp

The crimp applied to the wire barrel portion of the contact is the most compressed area and is most critical in ensuring optimum electrical and mechanical performance of the crimped contact. The crimp must be centered on the closed wire barrel. The crimp must result in an “F” crimp where the wire barrel forms a closed seam with no evidence of loose wire strands or wire strands visible in the seam. The crimp height and width must be within the dimensions given in Figure 5.

C. Wire Barrel Flash

Wire barrel flash is the formation that may appear on both sides of the wire barrel as a result of the crimping process. It must not exceed the dimensions given in Figure 3.

D. Wire End Extrusion Length

Wire end extrusion length is the wire conductor ends must protrude from the lateral leading edges of the wire crimp barrel within the dimensions given in Figure 3.

Any protruding wire strands must not impede the mating function of the contact.

E. Insulation End Extrusion Length

Insulation end extrusion length is the insulation ends must be visible and protrude from lateral leading edges of the insulation crimp barrel within dimensions given in Figure 3.

F. Bellmouth

The bellmouth shall conform to the dimensions given in Figure 3.

G. Locking Lance

The locking lance shall be set within the dimensions given in Figure 5.

H. Insulation Barrel Crimp

The crimp applied to the insulation barrel of the contact must result in either an “F” crimp where the insulation barrel forms a closed seam with no evidence of wire insulation in the seam or an overlap crimp where the tips of the insulation barrel wraps overlap each other and wrap firmly around the wire insulation without cutting into the wire insulation. The crimp height and width must be within the dimensions given in Figure 5.

Checking Items	Specification
Cut-off Tab Length	0~0.2 mm
Wire End Extrusion Length	0.1~ 0.5 mm
Insulation End Extrusion Length	0.1~ 0.5 mm
Bellmouth Length	0~0.25 mm
Wire Barrel Flash	0.2 mm max.

Figure 3

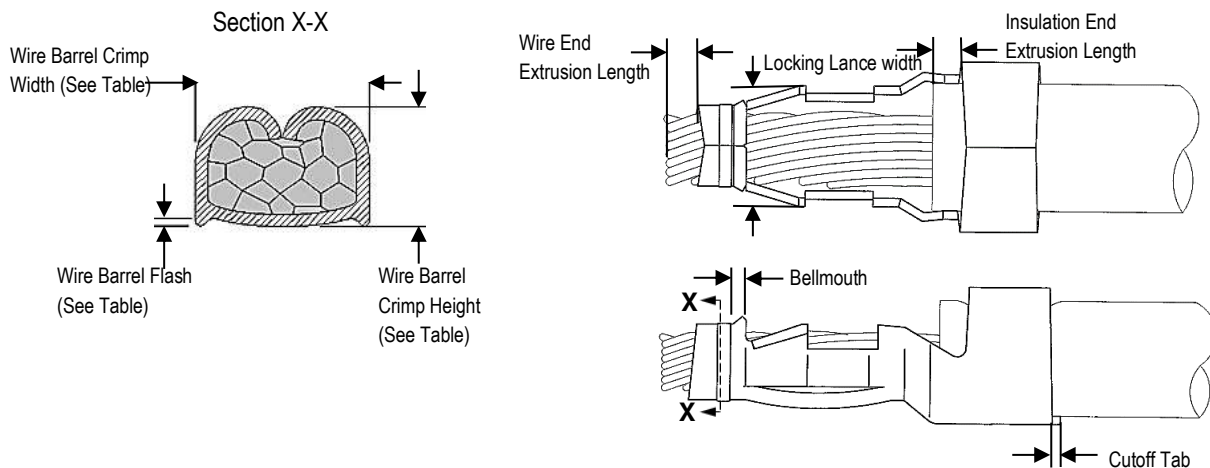

Figure 4

Part Number	Wire Size (mm ²)[AWG]	Wire Crimp		Insulation Crimp		Locking Lance Width(mm)	Crimp Tensile Strength (N)[kg]
		Width(mm)	Height(mm)	Width(mm)	Height(mm)(Ref)		
2393237	3.29 [12]	3.0	2.50	5.0	4.5	3.80~4.10	15.0 [1.5]
2393227	2.08 [14]	1.9	1.61±0.05	4.0	4.0	3.00~3.30	29.4 [3.0]
2393222	1.32 [16]	1.9	1.25±0.05	4.0	3.7	2.70~2.90	24.5 [2.5]
	0.85 [18]		1.08±0.05		3.6		19.6 [2.0]
2393199	0.85 [18]	1.4	1.15±0.05	3.3	3.2	2.10~2.30	19.6 [2.0]
	0.52 [20]		1.00±0.05		3.0		19.6 [2.0]
	0.34 [22]		0.85±0.05		2.8		19.6 [2.0]
2393261	0.34 [22]	1.4	0.71±0.03	2.6	2.8	2.10~2.30	19.6 [2.0]
	0.22 [24]		0.71±0.03		2.7		19.6 [2.0]
	0.14 [26]		0.65±0.03		2.6		19.6 [2.0]

Figure 5

3.5. PC Board

The pc board thickness and hole size for the contacts should be within the tolerances specified in Figure 6.

Part Number	Wire Size (AWG)	PCB Hole Size(mm)	PCB Thickness(mm)
2393237	12	3.55±0.05	1.6±0.05
2393227	14	2.55±0.05	
2393222	18~16	2.40±0.05	
2393199	22~18	1.85±0.05	
2393261	26~22	1.85±0.05	

Figure 6

The holes in the pc board for the solder tines must be drilled and plated through as shown in Figure 7.

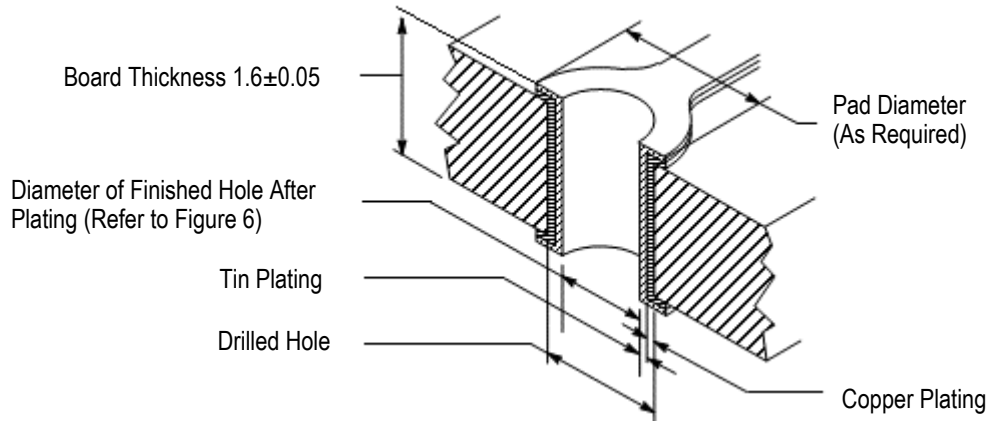

Figure 7

3.6. Inserting Contact into PC Board Hole

The contact must be inserted into the pc board hole until the locking lance(s) are through the PCB hole. See Figure 8.

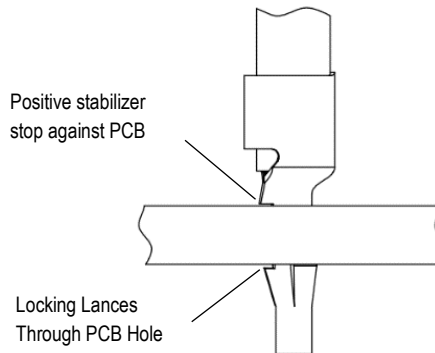

Figure 8

3.7. Soldering

A. Process

The contacts can be soldered using wave soldering or equivalent soldering techniques. Temperature and exposure time shall be as specified in Figure 9.

Soldering Process	Temperature	Time (At Max Temperature)
Wave	260°C (Wave Temperature)	5 Seconds

Figure 9

B. Flux Selection

The contact wire barrel must be fluxed prior to soldering with a rosin base flux. Selection of the flux will depend on the type of pc board and other components mounted on the board. Additionally, the flux must be compatible with the wave solder line, manufacturing, health, and safety requirements. Call the number at the bottom of page 1 for consideration of other types of flux. Flux that is compatible with these connectors are provided in Figure 10.

Type	Activity	Residue	Commercial Designation	
			ALPHA	KESTER
RMA	Mild	Corrosive or Noncorrosive	N/A	145
Center (Activated)	Medium	Corrosive or Noncorrosive	800	N/A

Figure 10

C. Cleaning

After soldering, removal of fluxes, residues, and activators is necessary. Consult with the supplier of the solder and flux for recommended cleaning solvents.

D. Drying

When drying cleaned contacts and pc boards, temperature limitations must not be exceeded: -40° to 105°C. Excessive temperatures may cause contact degradation.

4. QUALIFICATION

4.1. Underwriters Laboratories Inc. (UL)

Miniature AMP-IN contacts are recognized by Underwriters Laboratories Inc. (UL) in File E13288.

5. TOOLING

Tooling information for product part numbers is available from www.te.com or by calling the Product Information Center at the number at the bottom of page 2.

Part Number	Applicator-Ocean Atlantic	Applicator- Ocean Pacific
2393237	2401848-1	2-2401848-1
2393227	2398992-1	2-2398992-1
2393222	2398991-1	2-2398991-1
2393199	2398990-1	2-2398990-1
2393261	2399972-1	2-2399972-1

Figure 11

6. VISUAL AID

The illustration below shows a typical application of miniature AMP-IN contacts. This illustration should be used by production personnel to ensure a correctly applied product. Applications which do not appear correct should be inspected using the information in the preceding pages of this specification and in the instructional material shipped with the product or tooling.

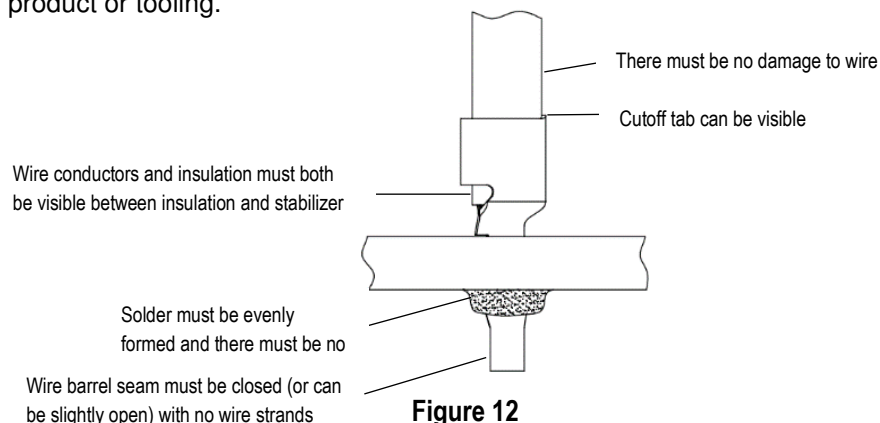

Figure 12