

PRODUCT SPECIFICATION FOR BCM CONNECTOR

72 WAY BCM CONNECTOR / 2287336

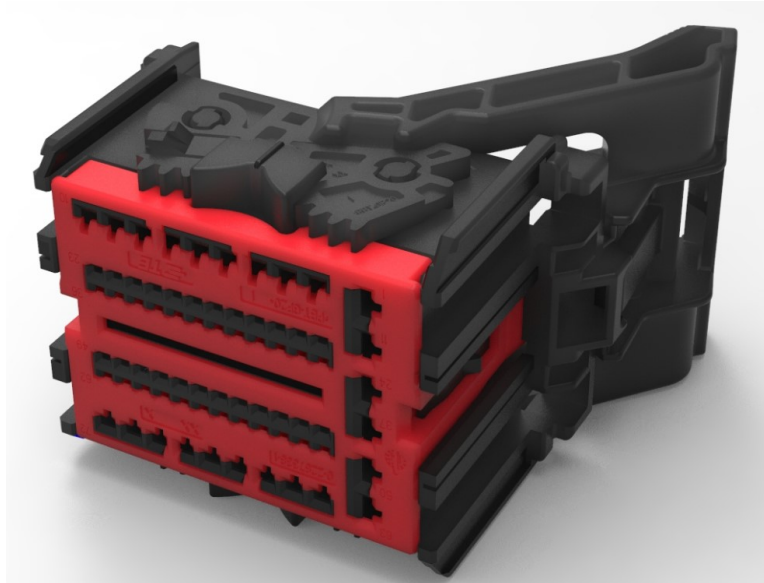

50 WAY BCM CONNECTOR / 2287277

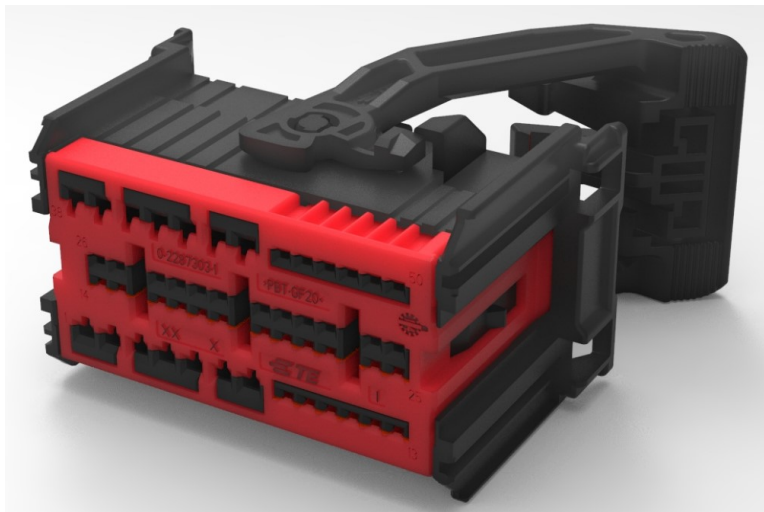



72 & 50 WAY BCM CONNECTOR

1. PRODUCT OVERVIEW

1.1. OPERATING TEMPERATURE

1.2. VALID TE SPECIFICATIONS

1.3. SOCKET HOUSING

1.3.1. 72 WAY CONNECTOR

1.3.2. 50 WAY CONNECTOR

1.4. CONTACTS

1.4.1. 0.64 GENERATION Y – TE CONNECTIVITY

1.4.2. FCI MX150 OR YAZAKI 1.5

1.4.3. SUMITOMO 2.8

2. TEST REQUIREMENT

2.1. CONNECTOR – MECHANICAL TESTS / ENVIRONMENTAL TEST

3. REVISION RECORD

1. PRODUCT OVERVIEW.

Applicable product description part no's. are as follows:

DESIGNATION	PARTNUMBER
INTERFACE 72 WAY – NO HEADER TOOLED BY TE CONNECTIVITY	SEE INTERFACE SPEC. 114-94321
PLUG ASSEMBLY 72 WAY UNSEALD HYBRID CONNECTOR	SEE DRAWING 2287336
	1-2287336-1 – CODING A / 1-2287336-2 – CODING B
COVER 90° FOR 72 WAY UNSEALED HYBRID CONNECTOR	1-2287341-2
INTERFACE 50 WAY - NO HEADER TOOLED BY TE CONNECTIVITY	SEE INTERFACE SPEC. 114-94317
PLUG ASSEMBLY 50 WAY UNSEALD HYBRID CONNECTOR	SEE DRAWING 2287277
	0-2287277-1 – CODING A / 0-2287277-2 - CODING B
COVER 90° FOR 50 WAY UNSEALD HYBRID CONNECTOR	0-2287334-1
0.64 GENERATION Y FEMALE TERMINAL	TE CONNECTIVITY - SEE 1.4 CONTACTS / PAGE 6
1.5 UNSEALED FEMALE TERMINAL	FCI PART / YAZAKI PART – SEE 1.4 CONTACTS / PAGE 6
2.8 UNSEALED FEMALE TERMINAL	SUMITOMO PART – SEE 1.4 CONTACTS / PAGE 6

1.1. OPERATING TEMPERATURE

-40° to +100°C

1.2. VALID TE SPECIFICATIONS

114-94321	INTERFACE DRAWING – 72 WAY HEADER SPECIFICATION
114-94317	INTERFACE DRAWING – 50 WAY HEADER SPECIFICATION
114-94370	APPLICATION SPEC. – 72 WAY BCM CONNECTOR
114-94371	APPLICATION SPEC. – 50 WAY BCM CONNECTOR

1.3 SOCKET HOUSING

1.3.1 72 WAY CONNECTOR

ASSEMBLY OVERVIEW
COVER IS A SEPARATE SALEABLE PART

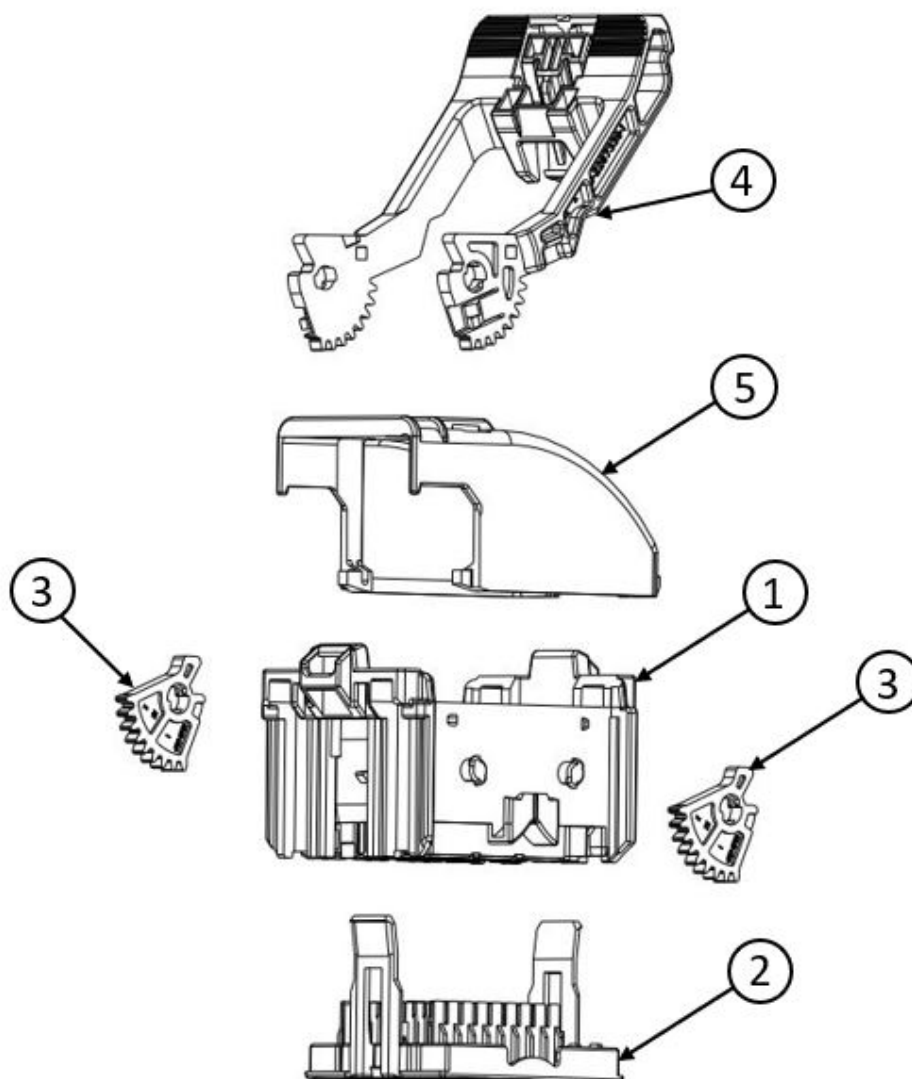

1	72 WAY BCM CONNECTOR FEMALE HOUSING
2	72 WAY BCM CONNECTOR TPA
3	72 WAY BCM CONNECTOR PINION GEAR
4	72 WAY BCM CONNECTOR LEVER
5	72 WAY BCM CONNECTOR COVER

1.3.2 50 WAY CONNECTOR

ASSEMBLY OVERVIEW
COVER IS A SEPARATE SALEABLE PART

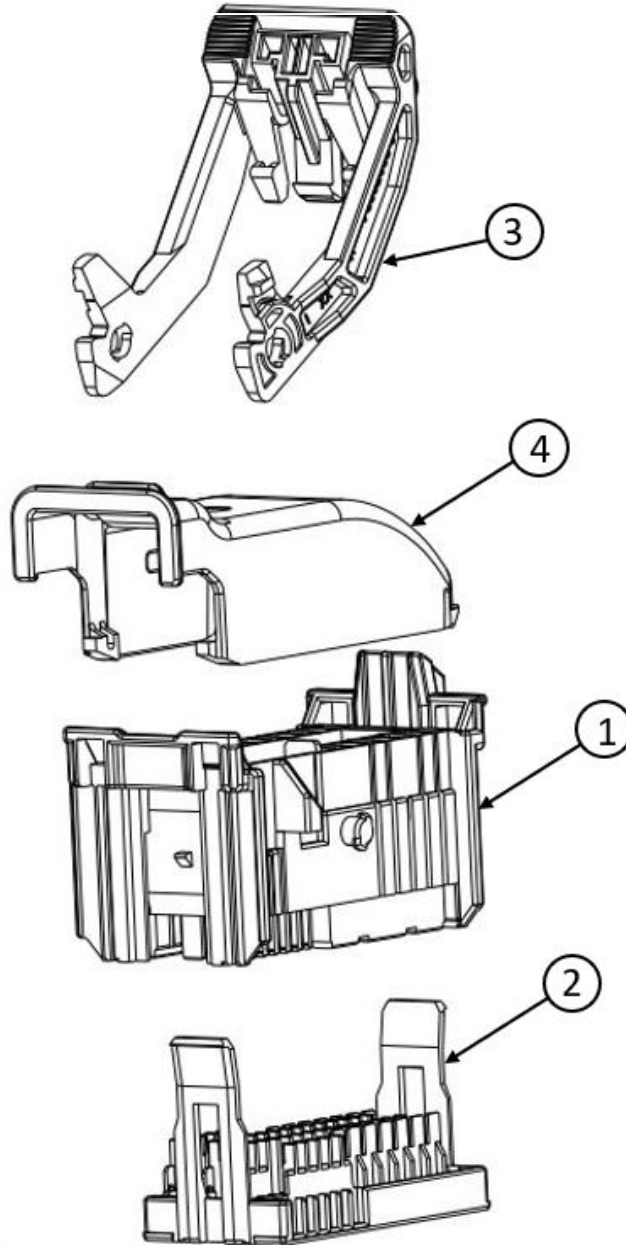

1	50 WAY BCM CONNECTOR FEMALE HOUSING
2	50 WAY BCM CONNECTOR TPA
3	50 WAY BCM CONNECTOR LEVER
4	50 WAY BCM CONNECTOR COVER

1.4 CONTACTS

1.4.1 0.64 GENERATION Y – TE CONNECTIVITY



WIRE SIZE RANGE	0.35 – 0.75mm ²
PART NO.	SEE TABLE ON PAGE 7
SURFACE FINISH	TINNED
MAX. TEMPERATURE	+100°C

1.4.2 FCI MX150 / YAZAKI 1.5



WIRE SIZE RANGE	0.35 – 1.50mm ²
PART NO.	SEE TABLE ON PAGE 7
SURFACE FINISH	TINNED / SILVER / GOLD
MAX. TEMPERATURE	+125°C

1.4.3 SUMITOMO 2.8



WIRE SIZE RANGE	0.35 – 3.0mm ²
PART NO.	SEE TABLE ON PAGE 7
SURFACE FINISH	TINNED
MAX. TEMPERATURE	+125°C

0.64 GENERATION

PART-NO	WIRE SIZE RANGE	SURFACE FINISH
1-1456841-1	0.35-0.50mm ²	Sn
1-1456841-2	0.75mm ²	Sn
1-2098753-5	0.35-0.50mm ²	Sn
1-2098753-6	0.75mm ²	Sn
2098762-1	0.35-0.50mm ²	Sn
2098762-2	0.75mm ²	Sn

FCI MX150

PART-NO	WIRE SIZE RANGE	SURFACE FINISH
33012-2023	0.35-0.50mm ²	Sn
33012-3023	0.35-0.50mm ²	Sn
33012-2022	0.75-1.0mm ²	Sn
33012-3022	0.75-1.0mm ²	Sn
33012-2021	1.5-2.0mm ²	Sn
33012-3021	1.5-2.0mm ²	Sn
33001-2023	0.35-0.50mm ²	Au
33001-3023	0.35-0.50mm ²	Au
33001-2022	0.75-1.0mm ²	Au
33001-3022	0.75-1.0mm ²	Au
33001-2021	1.5-2.0mm ²	Au
33001-3021	1.5-2.0mm ²	Au
33001-4023	0.35-0.50mm ²	Ag
33001-5023	0.35-0.50mm ²	Ag
33001-4022	0.75-1.0mm ²	Ag
33001-5022	0.75-1.0mm ²	Ag
33001-4021	1.5-2.0mm ²	Ag
33001-5021	1.5-2.0mm ²	Ag

YAZAKI 1.5

PART-NO	WIRE SIZE RANGE	SURFACE FINISH
7116-6315-02	0.35-0.50mm ²	Sn
7116-6316-02	0.75-1.0mm ²	Sn
7116-6317-02	1.5mm ²	Sn

SUMITOMO 2.8

PART-NO	WIRE SIZE RANGE	SURFACE FINISH
8240-0477	0.35mm ²	Sn
8240-0423	0.5-1.0mm ²	Sn
8240-0424	1.5-2.5mm ²	Sn
8240-0425	3.0mm ²	Sn

2. TEST REQUIREMENTS

	Test Description	Requirement	Procedure
	Examination of Product	Meets requirements of product drawing.	Visual, dimensional and functional per Applicable quality inspection plan.
2.1. CONNECTOR – MECHANICAL TESTS			
TERMINAL- CONNECTOR INSERTION/RETENTION FORCE FOR SIGNAL TERMINALS.			
1	Terminal Insertion Force 0.64 GENY	Max. 30 N	V= 50 mm/min. Qualification acc. To SAE/USCAR-2; Rev. 6 §5.4.1
	Terminal Push Through Force 0.64 GENY	Max. 50N or Cable buckles	
	Terminal Extraction Force 0.64 GENY (Primary lock only)	Min. 30 N	
	Terminal Extraction Force 0.64 GENY (Primary and Secondary locks After Moisture)	Min. 60 N	
	Terminal Extraction Force 0.64 GENY (Primary and Secondary locks Temp/Humidity)	Min. 50 N	
TERMINAL- CONNECTOR INSERTION/RETENTION FORCE FOR POWER TERMINALS.			
2	Terminal Insertion Force 1.5 FCI/YAZAKI	Max. 30 N	V= 50 mm/min. Qualification acc. To SAE/USCAR-2; Rev. 6 §5.4.1
	Terminal Push Through Force 1.5 FCI/YAZAKI	Max. 50N or Cable buckles	
	Terminal Extraction Force 1.5 FCI/YAZAKI (Primary lock only)	Min. 45 N	
	Terminal Extraction Force 1.5 FCI/YAZAKI (Primary and Secondary locks After Moisture)	Min. 70 N	
	Terminal Extraction Force 1.5 FCI/YAZAKI (Primary and Secondary locks Temp/Humidity)	Min. 50 N	
TERMINAL- CONNECTOR INSERTION/RETENTION FORCE FOR POWER TERMINALS.			
3	Terminal Insertion Force 2.8 SUMITOMO	Max. 30 N	V= 50 mm/min. Qualification acc. To SAE/USCAR-2; Rev. 6 §5.4.1
	Terminal Push Through Force 2.8 SUMITOMO	Max. 50N or Cable buckles	
	Terminal Extraction Force 2.8 SUMITOMO (Primary lock only)	Min. 60 N	

	Terminal Extraction Force 2.8 SUMITOMO (Primary and Secondary locks After Moisture)	Min. 90 N	
	Terminal Extraction Force 2.8 SUMITOMO (Primary and Secondary locks Temp/Humidity)	Min. 50 N	
CONNECTOR - CONNECTOR MATING / UNMATING FORCE (CONNECTORS WITH MECHANICAL ASSIST)			
4	Connector-Connector Mating Force (Mechanical assist, Pre-lock)	Max. 75N	V= 50 mm/min Fully populated with terminals. Qualification acc. To SAE/USCAR-2; Rev. 6 §5.4.3
	Connector-Connector Unmating Force (Mechanical assist, Locked position)	Max. 75N	
	Connector-Connector Unmating Force (Mechanical assist, Release the assist feature)	Min. 60N	
MISCELLANEOUS COMPONENTS ENGAGE/DISENGAGE (TPA)			
5	TPA Preset to Lock Force (w/terminals installed in all available cavities)	Max. 60N	V= 50 mm/min Qualification acc. To SAE/USCAR-2; Rev. 6 §5.4.5
	TPA Preset to Lock Force (w/o terminals)	Min. 15N	See TE Spec. 114-94370 / 114-94371
	TPA Lock to Preset Force (w/terminals installed in all available cavities)	Max. 60N	
	TPA Lock to Preset Force	Min. 18N	
	TPA Complete Removal from Pre-stage on Unmated Connector	Min. 25N	
MISCELLANEOUS COMPONENTS ENGAGE/DISENGAGE (WIRE DRESS COVER)			
6	Wire Dress Cover Engage	Max. 60N	V= 50 mm/min Qualification acc. To SAE/USCAR-2; Rev. 6 §5.4.5
	Wire Dress Cover Disengage	Min. 110N	
POLARIZATION FEATURE EFFECTIVENESS			
7	Polarization Feature Force, Correct Orientation but with wrong code	F >150N	V= 50 mm/min No electrical contact. Qualification acc. To SAE/USCAR-2; Rev. 6 §5.4.4

	Polarization Feature Force, Incorrect Orientation		
CAVITY DAMAGE SUSCEPTIBILITY			
8	Cavity Damage force fully applied to TPA	<p>Signal terminal: 0.64 GEN Y = Min. 60N</p> <p>Power terminal: 1.5 FCI/YAZAKI = Min. 80N 2.8 SUMITOMO =Min. 80N</p>	<p>V= 50 mm/min</p> <p>Qualification acc. To SAE/USCAR-2; Rev. 6 §5.4.9</p>
	Extraction Force with Primary and Secondary Locks (Before Moisture)	<p>Signal terminal: 0.64-1.2 GEN Y = Min. 60N</p> <p>Power terminal: 1.5-1.8 FCI/YAZAKI/FCI = Min. 70N 2.8-3.0 SUMITOMO = Min. 90N</p>	
CONNECTOR DROP TEST			
9	Connector Drop Test	No Cracks Occur	<p>Distance Minimum 1meter height</p> <p>Qualification acc. To SAE/USCAR-2; Rev. 6; §5.4.8</p>
DRY CIRCUIT RESISTANCE			
10	Dry Circuit Resistance	<p>Signal terminal: 0.64 GEN Y = 20 mOhms Max (Tin)</p> <p>Power terminal: 1.5 FCI/YAZAKI = 10 mOhms 2.8 SUMITOMO = 5 mOhms Max</p>	<p>Qualification acc. To SAE/USCAR-2; Rev. 6; §5.3.1</p>
VIBRATION			
11	Vibration (W/Circuit Continuity Monitoring)	<p>Connector Conditioning & No loss of electrical continuity (and any instance of resistor current dropping below 95 mA), for more than 1 microsecond</p>	<p>Qualification acc. To SAE/USCAR-2; Rev. 6; §5.4.6</p> <p>V1 Tested</p>
THERMAL SHOCK			
12	Thermal Shock (w/Circuit Continuity Monitoring)	<p>Connector Conditioning & No loss of electrical continuity (and any instance of resistor current dropping below 95 mA), for</p>	<p>Qualification acc. To SAE/USCAR-2; Rev. 6; §5.6.1</p>

		more than 1 microsecond	
TEMPERATURE / HUMIDITY CYCLING			
13	Temperature Humidity	Connector Conditioning Only	Connector Conditioning Only
HIGH TEMPERATURE EXPOSURE			
14	High Temperature Exposure	Connector Conditioning Only	Connector Conditioning Only
DRY CIRCUIT RESISTANCE			
13	Dry Circuit Resistance	<p>Signal terminal: 0.64 GEN Y = 20 mOhms Max (Tin)</p> <p>Power terminal: 1.5 FCI/YAZAKI = 10 mOhms Max 2.8 SUMITOMO = 5 mOhms Max</p>	Qualification acc. To SAE/USCAR-2; Rev. 6; §5.3.1
VOLTAGE DROP			
14	Voltage Drop	<p>Signal terminal: 0.64 GEN Y = 20 mOhms Max (Tin)</p> <p>Power terminal: 1.5 FCI/YAZAKI = 20 mOhms Max 2.8 SUMITOMO = 5 mOhms Max</p>	Qualification acc. To SAE/USCAR-2; Rev. 6; §5.3.2
TEMPERATURE / HUMIDITY CYCLING (ISOLATION RESISTANCE)			
15	Temperature Humidity (Isolation Resistance)	Resistance between every combination of two adjacent terminals must exceed 100 Mohm at 500 VDC (Includes terminals that may be separated by one or more vacant terminal cavities)	Qualification acc. To SAE/USCAR-2; Rev. 6; §5.5.1
TEMPERATURE / HUMIDITY CYCLING (EXTRACTION FORCE)			
16	Terminal to Connector Extraction Force with Primary and Secondary Locks after Temperature Humidity	Min. 50 N	Qualification acc. To SAE/USCAR-2; Rev. 6; §5.4.1

3. REVISION RECORD

<u>LTR</u>	<u>REVISION RECORD</u>	<u>DWN</u>	<u>APP</u>	<u>DATE</u>
A	Initial Release	Sathya Raj N	Parusuram T	18022020
B	Product-Specification updated	Georg Puckel	Konrad Roth	11042022