

PRODUCT SPECIFICATION

1. SCOPE

1.1. Content

This specification covers the performance, tests, and quality requirements for the AMP-LEAF* Connector assembly, with gold and tin plated contacts and housings molded with diallyl phthalate, phenolic and nylon material.

1.2. Qualification

When tests are performed on the subject product line, the procedures specified in AMP 109 Series specifications shall be used. All inspections shall be performed using the applicable inspection plan and product drawing.

2. APPLICABLE DOCUMENTS

The following documents form a part of this specification to the extent specified herein. In the event of conflict between requirements of this specification and the product drawing, the product drawing shall take precedence. In the event of conflict between the requirements of this specification and the referenced documents, this specification shall take precedence.

2.1. AMP Specifications

- A. 109-1: General Requirements for Test Specifications
- B. 109 Series: Test Specifications as indicated in Figure 1.
(Comply with MIL-STD-202, MIL-STD-1344 and EIA RS-364)
- C. Corporate Bulletin 76: Cross-reference between AMP Test Specifications and Military or Commercial Documents
- D. 501- : Test Report

2.3. Military Standard

MIL-STD-275: Printed Wiring for Electronic Equipment

*Trademark of AMP Incorporated.

©COPYRIGHT 1975, 86
 BY AMP INCORPORATED HARRISBURG, PA. ALL INTERNATIONAL
 RIGHTS RESERVED. AMP PRODUCTS MAY BE COVERED BY U.S. AND
 FOREIGN PATENTS AND/OR PATENTS PENDING.

				DR C. E. Fritz 8/27/75		AMP AMP INCORPORATED Harrisburg, Pa. 17105		
				CHK H. J. Hagan 8/27/75				
				APP D. N. Bushey 8/27/75		LOC B	NO 108-9013	REV G
I	G	Revise per ECN AD-0398	<i>RLC</i>	<i>10/29</i> <i>86</i>	SHEET 1 OF 11	TITLE CONNECTOR, AMP-LEAF		
DIST 14	LTR	REVISION RECORD	APP	DATE				

3. REQUIREMENTS

3.1. Design and Construction

Connectors shall be of the design, construction and physical dimensions specified on the applicable product drawing.

3.2. Material

A. Contacts

- (1) Phosphor bronze, gold over nickel plating
- (2) Beryllium copper, gold over nickel plating
- (3) Phosphor bronze, tin over nickel plating
- (4) Beryllium copper, tin over nickel plating

B. Housings

- (1) Diallyl phthalate
- (2) Phenolic
- (3) Polyester

3.3. Ratings

A. Current: 5 amperes maximum with not more than 6 adjacent or opposing circuits carrying this current

B. Operating Temperature:

- (1) Diallyl phthalate: -65 to 125°C
- (2) Phenolic and Polyester: -55 to 105°C

3.4. Performance and Test Description

Connectors shall be designed to meet the electrical, mechanical, and environmental performance requirements specified in Figure 1.

AMP

AMP INCORPORATED
Harrisburg, Pa. 17105

LOC

B

SHEET

2 OF 11

NO

108-9013

REV

G

3.5. Test Requirements and Procedures Summary

Test Description	Requirement	Procedure																								
Examination of Product	Meets requirements of product drawing.	Visual, dimensional, and functional per applicable inspection plan.																								
ELECTRICAL																										
Termination Resistance, Dry Circuit	6 milliohms maximum.	Subject mated contacts assembled in housing to 50 mv open circuit at 100 ma maximum, see Figure 4; AMP Spec 109-6-1.																								
Dielectric Withstanding Voltage	<table border="0"> <tr> <td>Test Voltage (rms)</td> <td>Altitude Feet</td> </tr> <tr> <td>1800</td> <td>Sea Level</td> </tr> <tr> <td>675</td> <td>50,000</td> </tr> </table> <p>2 ma maximum leakage current. No breakdown or flashover.</p>	Test Voltage (rms)	Altitude Feet	1800	Sea Level	675	50,000	Test between adjacent contacts of unmated connector assemblies; AMP Spec 109-29-1.																		
Test Voltage (rms)	Altitude Feet																									
1800	Sea Level																									
675	50,000																									
Insulation Resistance	5000 megohms minimum initial. 1000 megohms minimum final.	Test between adjacent contacts of unmated connector assembly; at 500 vdc; AMP Spec 109-28-4.																								
Current Cycling	<p>Crimp resistance shall not exceed final value.</p> <table border="0"> <tr> <td>Wire Size, AWG</td> <td>Resistance, milliohms</td> <td>Current maximum amperes</td> <td>Final</td> </tr> <tr> <td>26</td> <td>1.0</td> <td>4.0</td> <td></td> </tr> <tr> <td>24</td> <td>3.0</td> <td>3.3</td> <td></td> </tr> <tr> <td>22</td> <td>5.0</td> <td>2.0</td> <td></td> </tr> <tr> <td>20</td> <td>7.5</td> <td>1.2</td> <td></td> </tr> <tr> <td>18</td> <td>10.0</td> <td>.8</td> <td></td> </tr> </table>	Wire Size, AWG	Resistance, milliohms	Current maximum amperes	Final	26	1.0	4.0		24	3.0	3.3		22	5.0	2.0		20	7.5	1.2		18	10.0	.8		Subject mated contacts to 50 cycles at 125% rated current for 30 minutes "ON" - 15 minutes "OFF"; AMP Spec 109-51, cond B, test method 3.
Wire Size, AWG	Resistance, milliohms	Current maximum amperes	Final																							
26	1.0	4.0																								
24	3.0	3.3																								
22	5.0	2.0																								
20	7.5	1.2																								
18	10.0	.8																								

Figure 1 (cont)

AMP	AMP INCORPORATED Harrisburg, Pa. 17105	LOC	SHEET	NO	REV
		B	3 OF 11	108-9013	G

Test Description	Requirement	Procedure		
Crimp Resistance, Specified Current	Wire Size, AWG	Resistance, milliohms	Measure potential drop across crimped contact at 1 ampere maximum, see Figure 5; AMP Spec 109-25.	
		Initial		Final
	26	2.5		4.0
	24	2.0		3.3
	22	1.2		2.0
	20	0.7		1.2
18	0.5	0.8		

MECHANICAL

Vibration (a)	No discontinuities greater than 1 microsecond.	Subject mated connectors to 10-55-10 Hz traversed in 1 minute at .06 inches total excursion; 2 hours in each of 3 mutually perpendicular planes; AMP Spec 109-21-1.
Physical Shock (a)	No discontinuities greater than 1 microsecond.	Subject mated connectors to 100 G's sawtooth in 6 milliseconds; 3 shocks in each direction applied along the 3 mutually perpendicular planes total 18 shocks; AMP Spec 109-26-9.
Contact Retention	Contacts shall not dislodge from its normal locking position.	Apply axial load of 10 pounds to crimped contacts on 20 or larger AWG wire; AMP Spec 109-30 except grip wire.
Contact Engaging Force	16 ounces maximum per contact pair.	Measure force to engage using gage 2, see Figure 6; AMP Spec 109-35.
Contact Separating Force	2 ounces minimum per contact pair.	Size 3 times using gage 2, see Figure 6, insert gage 1 and measure force to separate; AMP Spec 109-35.

Figure 1 (cont)

AMP AMP INCORPORATED Harrisburg, Pa. 17105	LOC	SHEET	NO	REV
	B	4 OF 11	108-9013	G

Test Description	Requirement	Procedure												
Crimp Tensile	<table border="1"> <thead> <tr> <th>Wire Size, AWG</th> <th>Crimp Tensile, pounds minimum</th> </tr> </thead> <tbody> <tr> <td>26</td> <td>5</td> </tr> <tr> <td>24</td> <td>8</td> </tr> <tr> <td>22</td> <td>12</td> </tr> <tr> <td>20</td> <td>20</td> </tr> <tr> <td>18</td> <td>30</td> </tr> </tbody> </table>	Wire Size, AWG	Crimp Tensile, pounds minimum	26	5	24	8	22	12	20	20	18	30	Determine crimp tensile at a rate of 1 inch/minute; AMP Spec 109-16.
Wire Size, AWG	Crimp Tensile, pounds minimum													
26	5													
24	8													
22	12													
20	20													
18	30													
Durability	No physical damage.	Mate and unmate, using gage 2, see Figure 6, for 250 cycles. <table border="1"> <thead> <tr> <th>Microinches</th> <th>Cycles</th> </tr> </thead> <tbody> <tr> <td>15 Gold</td> <td>100</td> </tr> <tr> <td>30 Gold</td> <td>250</td> </tr> <tr> <td>50 Gold</td> <td>500</td> </tr> <tr> <td>Tin</td> <td>100</td> </tr> </tbody> </table> AMP Spec 109-27.	Microinches	Cycles	15 Gold	100	30 Gold	250	50 Gold	500	Tin	100		
Microinches	Cycles													
15 Gold	100													
30 Gold	250													
50 Gold	500													
Tin	100													
ENVIRONMENTAL														
Thermal Shock (a)	No physical damage.	Subject mated connectors to 5 cycles between -65° and 125°C, for diallyl phthalate and between -55° and 105°C for phenolic and nylon; AMP Spec 109-22.												
Humidity-Temperature Cycling	5000 megohms minimum final insulation resistance.	Subject mated connectors to 10 humidity-temperature cycles between 25° and 65°C at 95% RH; AMP Spec 109-23, Method III, Cond B, with cold shock at -10°C.												
<p>(a) Shall show no evidence of damage, cracking or chipping.</p> <p style="text-align: center;">Figure 1 (end)</p>														
AMP AMP INCORPORATED Harrisburg, Pa. 17105	LOC B	SHEET 5 OF 11	NO 108-9013	REV G										

3.6. Connector Qualification and Requalification Tests and Sequences

Test or Examination	Test Group (a)			
	1	2	3	4 (c)
	Test Sequence (b)			
Examination of Product	1	1	1	1
Termination Resistance, Dry Circuit	2	2,10		2,4
Dielectric Withstanding Voltage	7			
Insulation Resistance	9			
Current Cycling			3	
Crimp Resistance, Specified Current			2	
Vibration		8		
Physical Shock		9		
Contact Retention	8	11		
Contact Engaging Force		3		
Contact Separating Force	5	4,7		
Crimp Tensile			4	
Durability	4	6		
Thermal Shock	3	5		
Humidity-Temperature Cycling	6			3

- (a) See Para 4.1.A.
- (b) Numbers indicate sequence in which tests are performed.
- (c) Tin plated contacts only.

Figure 2

4. QUALITY ASSURANCE PROVISIONS

4.1. Qualification Testing

A. Sample Selection

Connector housings and contacts shall be prepared in accordance with applicable Instruction Sheets. They shall be selected at random from current production. Test samples shall consist of 9 connectors of the greatest number of positions of each connector type offered, 6 each test group 1 and 3 each for test group 2. Test group 1 shall have 3 connectors board mounted and 3 connectors unmounted. The unmounted samples shall be tested for humidity, insulation resistance and dielectric. Two additional specimens shall be selected from the least number of positions offered and tested to test group 2. Thirty contacts of each style and desired wire size shall be tested to test group 3. Test group 4 shall consist of 3 connectors of the greatest number of positions board mounted.

B. Test Sequence

Qualification inspection shall be verified by testing samples as specified in Figure 2.

AMP

AMP INCORPORATED
Harrisburg, Pa. 17105

LOC
B

SHEET
6 OF 11

NO

108-9013

REV
G

C. Acceptance

- (1) Test results from development on pre-qualification samples will be used to determine upper and lower one-sided statistical tolerance limits for 99% reliability at 95% confidence, as follows. Let \bar{X} and s denote the sample average and standard deviation, respectively, of the test data. Let k denote the normal distribution one-sided tolerance factor for 95% confidence and 99% reliability. The value of k varies with sample size. Values of k are given in various tables, for example, NBS Handbook 91, Factors for One-Sided Tolerance Limits for Normal Distribution. Suitability of the normal distribution for representing the data shall be verified with normal probability plots, goodness of fit tests, etc.

Then the upper one-sided tolerance limit for 99% reliability at 95% confidence is given by $\bar{X} + ks$. The interpretation of this tolerance limit is as follows: based on the test data, and assuming a normal distribution for the test data, we can be 95% confident that 99% of the population of values represented by the sample data will not exceed $\bar{X} + ks$. For any test parameter for which there is specified an upper requirement which is not to be exceeded, satisfactory performance of the product is achieved when the value of $\bar{X} + ks$ does not exceed the requirement value.

The lower one-sided tolerance limit for 95% confidence and 99% reliability is given by $\bar{X} - ks$. This has a similar interpretation and corresponding application to lower requirement values.

- (2) Failures attributed to equipment, test setup, or operator deficiencies shall not disqualify the product. When product failure occurs, corrective action shall be taken and samples resubmitted for qualification.

4.2. Requalification Testing

Requalification shall be established by the cognizant divisional engineering function and may consist of all or any part of the overall qualification program provided that it is conducted within the required time period.

4.3. Quality Conformance Inspection

The applicable AMP inspection plan will specify the sampling acceptable quality level to be used. Dimensional and functional requirements shall be in accordance with the applicable product drawing and this specification.

AMP

AMP INCORPORATED
Harrisburg, Pa. 17105

LOC
B

SHEET
7 OF 11

NO
108-9013

REV
G

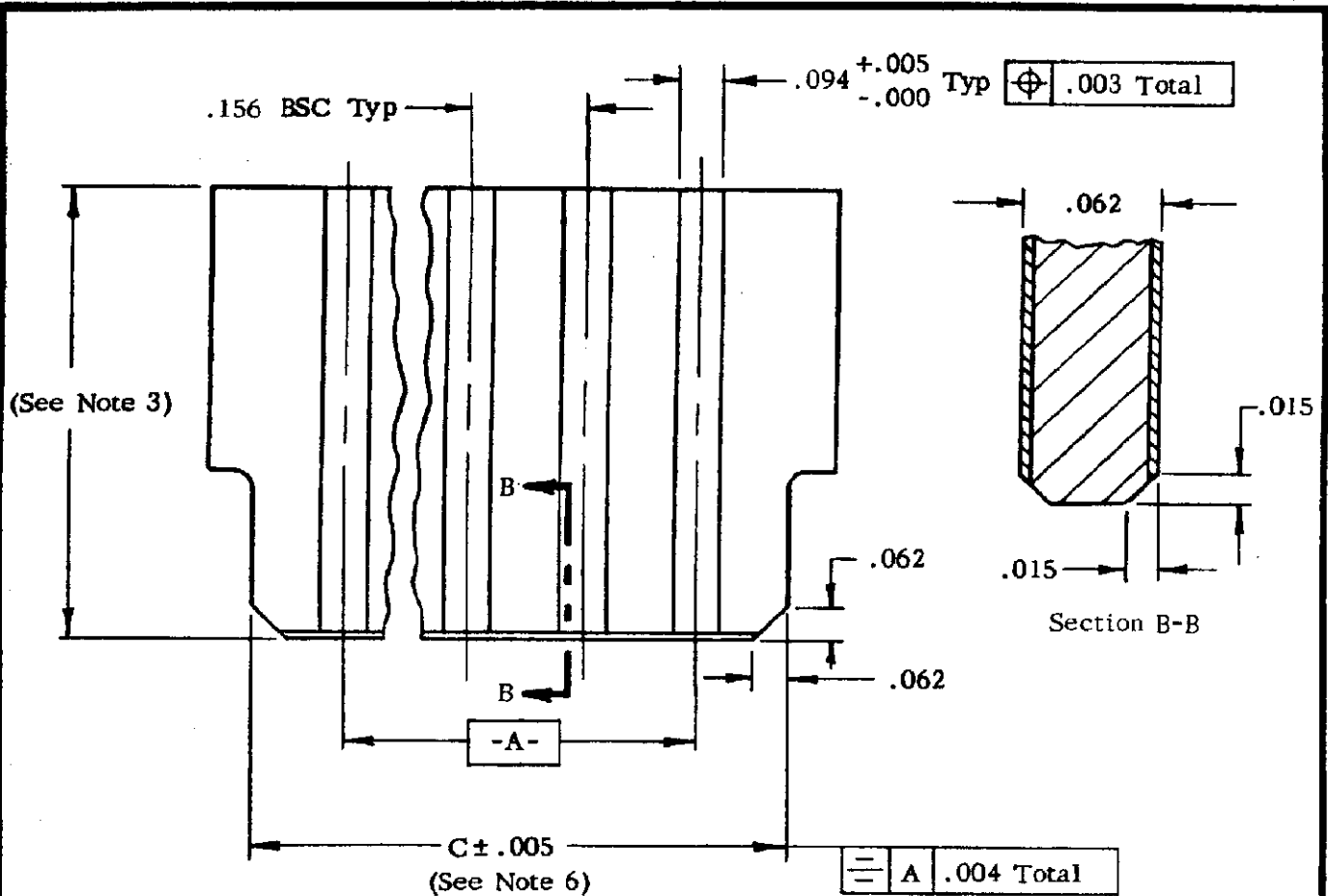

Notes:

1. Dimensions are in inches.
2. Unless otherwise specified, tolerance is $\pm .005$.
3. The test card shall extend $4.00 \pm .02$ from the receptacle after insertion.
4. Number of contacts shall be the same as on the corresponding printed wiring connector.
5. Printed circuit test board shall be 2 oz copper and gold over nickel plated per MIL-STD-275.
6. This dimension shall be the minimum connector card slot length minus .008.
7. Printed wiring shall be identical on both sides.

Figure 3

AMP AMP INCORPORATED Harrisburg, Pa. 17105	LOC	SHEET	NO	REV
	B	8 OF 11	108-9013	G

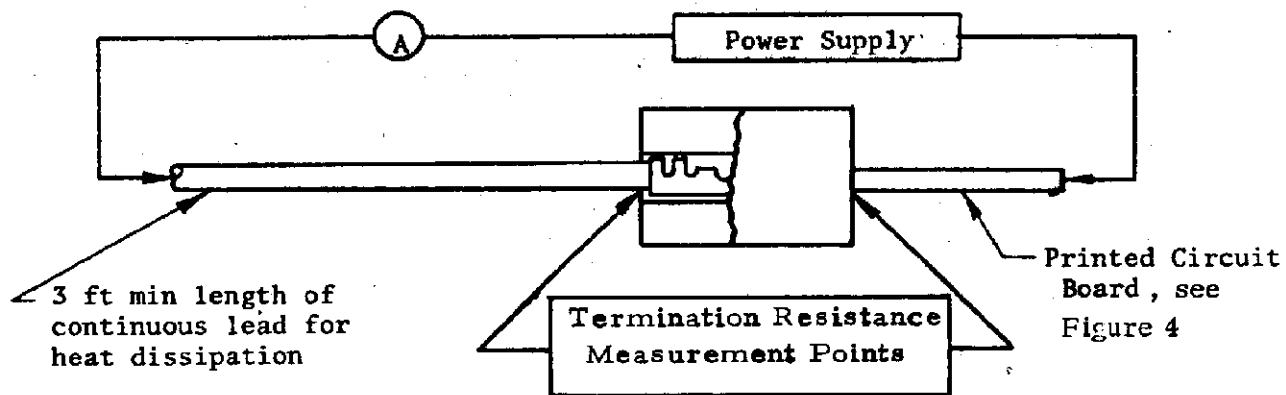
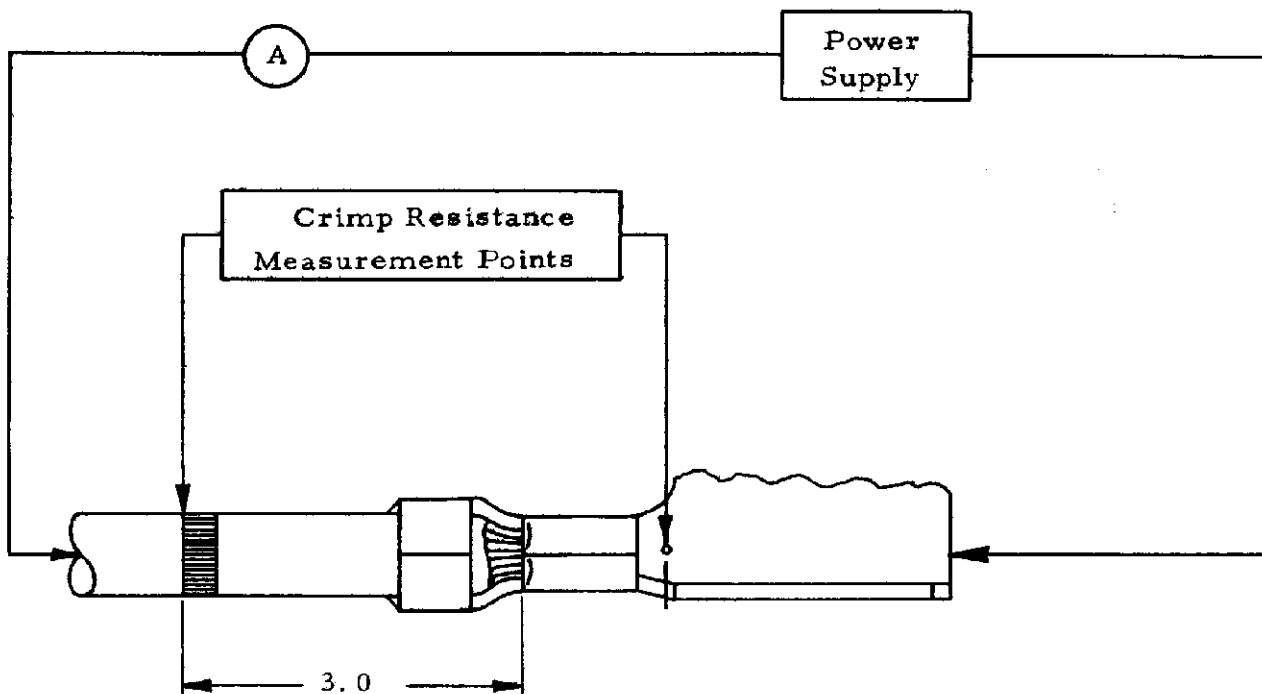

Figure 4

Termination Resistance Measurement Points

AMP AMP INCORPORATED Harrisburg, Pa. 17105	LOC	SHEET	NO	REV
	B	9 OF 11	108-9013	G



Note: The resistance of 3 inches of wire shall be measured and that amount deducted from the total value so as to show only the crimp resistance.

Figure 5

Crimp Resistance Measurement Point

AMP

AMP INCORPORATED
Harrisburg, Pa. 17105

LOC
B

SHEET
10 OF 11

NO

108-9013

REV
G

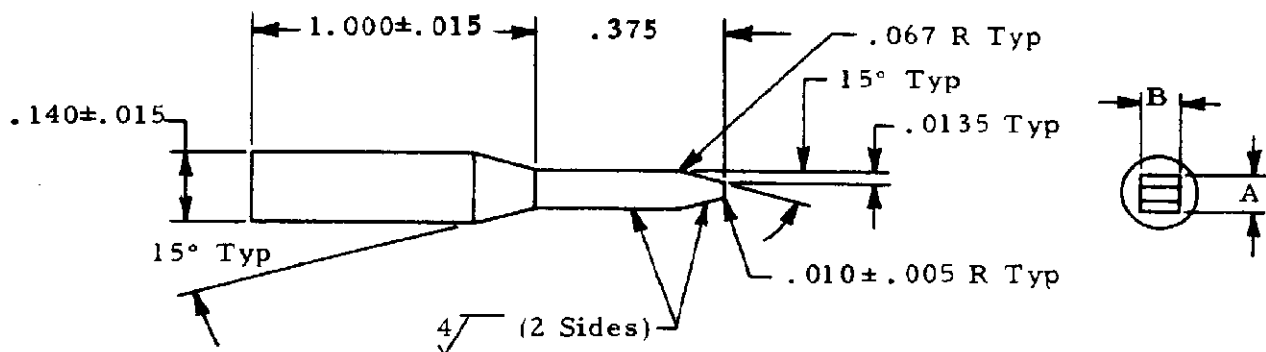

Notes:

1. Tolerance: $\pm .005$ or $\pm 2^\circ$ as applicable, unless otherwise specified.
2. Material: Tool steel, AISI type 02 per AMP Specification 100-15.
3. Heat treat: Rockwell C50-55.
4. Gage surface shall be clean of contaminants or lubricants.

Gage Number	A	B Centerline	
		100 & .125	.156
1	.0540 ^{+.0000} -.0001	.065	.088
2	.0700 ^{+.0001} -.0000		

Figure 7

Engaging and Separating Force Gages