



## 040 Rec Terminal

### 1. SCOPE

#### 1.1 Content

This specification describes the design, the characteristics, the tests and the quality requirements of the *040 Recep Terminal*.

#### 1.2 General Product Description

The contact system combines the features of robust construction and highest functional requirements.

The electrical contact is made by a rectangle pin with length 1.0mmx0.64mm.

#### 1.3 Application Sector

The contact system is designed for electronic applications with shrouded connectors and pin headers in automobiles.

#### 1.4 Qualification

When testing the 040 Rec products the following specified specifications and standards shall be used.

All tests have to be done using the applicable inspection plan and product.

### 2. REFERENCED DOCUMENTS

The following documents form a part of this specification to the extent specified herein.

In the case of a conflict between this specification and the specified documents, this specification has priority.

For the listed documents is valid the specification at the date of the first release of this specification.

#### 2.1 TE Specifications

- |              |  |
|--------------|--|
| A. 109-1     | General Requirements for Test Specifications |
| B. 114-61017 | Application Specification for 040 Rec        |
| C. 1743765   | Product drawing                              |

---

### 3. DESCRIPTION OF NOMENCLATURE

All design and construction data, such as dimensions, materials, wire sizes, etc., are shown in the product drawings.

### 4. PROPERTIES

#### 4.1 General Requirements

The product must correspond with the drawing, concerning the design and the physical dimensions.

#### 4.2 Technical Data - Ratings

A. Current carrying capacity	Max. 3A
B. Maximum mating cycles	10 (for tin-plated contacts)
C. Temperature range	-40 °C to +105 °C (for tin-plated contacts)
D. Voltage	14.0 ± 0.1 VDC

#### 4.3 Performance

Product is designed to meet the electrical, mechanical and environmental performance requirements specified in Chapter 4.4

Unless otherwise specified, all tests shall be performed at ambient environmental conditions.

**4.4 Test Requirements and Procedures Summary**

Test Description	Requirement		Procedure
<b>TERMINAL MECHANICAL</b>			
1. Visual Inspection	Assure parts used for testing are free of damage and obvious defects.		Visually, dimensionally and functionally inspected per applicable qualify inspection plan.
2. Terminal/Terminal Cycling	Preconditioning		Completely mate and un-mate each connector or terminal pair 10 times for tin-plated contacts.
3. Terminal-to-Terminal Engaging Force	0.2 ~ 0.8kgf		Operation speed: 50mm/min. Measure the force required to mate contact Initial.
4. Terminal-to-Terminal Disengaging Force	0.15 ~ 0.8kgf		Operation speed: 50mm/min. Measure the force required to un-mate contact.
5. Terminal Bend Resistance	Terminal shall not be damaged by a 1kgf load		Operation speed: 50mm/min. Original position, the terminal rotated 90° and 180° from the position shown in Fig. 1
6. Terminal Retention Force *	Secondary lock : 8kgf min		Operation speed: 50mm/min. Fix the housing after inserting crimped terminals. Extend one line of cable in axial direction at a position 50~100 mm away from crimped part
7. Crimp Tensile Strength (for copper/copper alloy conductor)	Wire Size (mm <sup>2</sup> ) 0.22	Strength (N) 4kgf min	Operation speed: 50mm/min. Apply an axial pull-off load to crimped wire of contact secured on the tester.

(Continued)

**TERMINAL ELECTRICAL**

8. Termination Resistance * (Low Level)	Initial: 10 mΩ Max. Final: 20 mΩ Max.	Subject mated contacts assembled in housing to 20±5mV open circuit at 100 mA Max. Fig. 2
9. Maximum Current Rating	Satisfy requirements of test item on the "4.5 sequence."	Max terminal current measurements are done. Temp rising 40°C Max. Fig. 3 (Refer to SAE/USCAR-2 5.3.3.3)
10. Current Cycling	40°C maximum temperature rise Over ambient. No ignition is allowed during the test.	Only perform the mate/unmate conditioning on a mated pair only once if the pair is used in multiple tests. 45 minutes "ON", 15 minutes "OFF" 1008 Hours
11. Instant Cutoff *	No electrical discontinuity exceeds 4.3V for more than 10 µsec shall occur.	Connect in series. Apply power with a waveform recorder and check. 5V, 100mA Fig. 4

**TERMINAL ENVIRONMENTAL**

12. Vibration *	Satisfy requirements of test item on the "4.5 sequence."	Frequency: 20-200 Sweep time: 3min Max. Acceleration: 4.4G Direction: X, Y, Z Duration: 40hours per each direction
13. Thermal Shock *	Satisfy requirements of test item on the "4.5 sequence."	-40°C/60 min. 105°C/60min. Temp transfer time: 5min. Max. Making this a cycle, repeat 200 cycles Fig. 5
14. Temp/Humidity *	Satisfy requirements of test item on the "4.5 sequence."	5cycle Fig. 6
15. Temp' Rising *	Satisfy requirements of test item on the "4.5 sequence."	Measure temperature rising at wire crimped by applied current to all positions.

(End)



\* The test is required with applicable housing and header product.

**4.5 Product Qualification Test Sequence**

Test Examination	Test Group (sample quantities: 10ea minimum)									
	TG1	TG2	TG3	TG4	TG5	TG6	TG7	TG8	TG9	
	Test Sequence *									
1. Visual Inspection	1,4	1,3	1,3	1,3	1,3	1,6	1,4	1,4	1,5	
2. Connector/Terminal Cycling	2									
3. Terminal-to-Terminal Engaging Force	2									
4. Terminal-to-Terminal Disengaging Force	3									
5. Terminal Bend Resistance		2								
6. Terminal Retention Force			2						4	
7. Crimp Tensile Strength				2						
8. Voltage Drop					2	5	3	3	3	
9. Maximum Current Rating						2				
10. Current Cycling						3				
11. Instant Cutoff							2			
12. Vibration							2			
13. Thermal Shock								2		
14. Temp/Humidity									2	
15. Temp Rising						2,4				

\* Numbers indicated sequence in which tests are performed.

## 4.6 Test Reference / Appendix

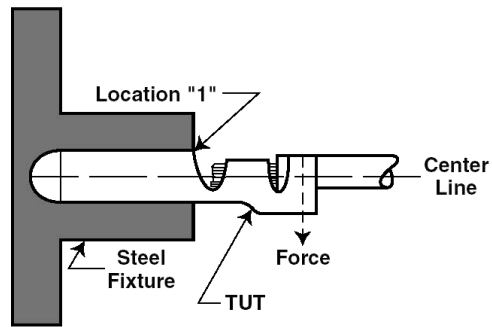

Fig. 1 Terminal Bend Resistance

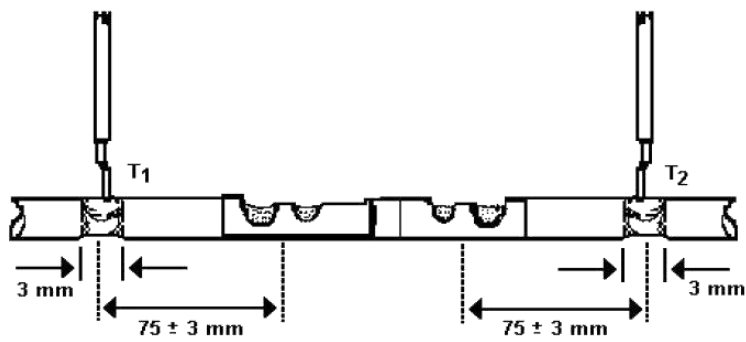

Fig. 2 Voltage Drop

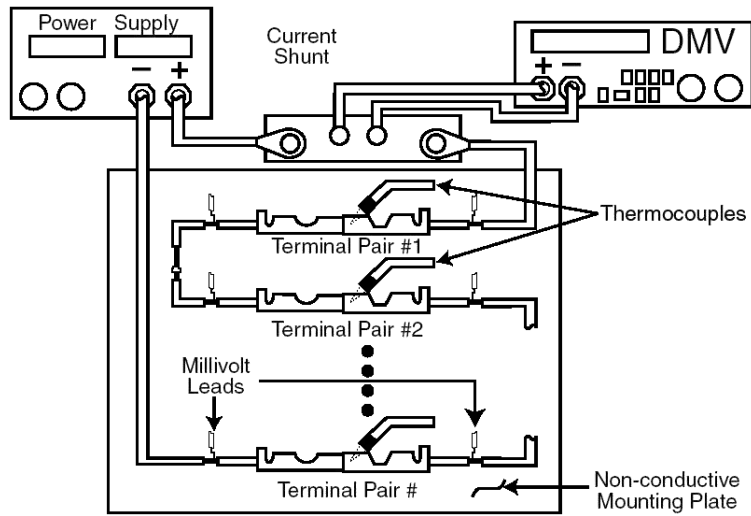

Fig. 3 Maximum Current Rating

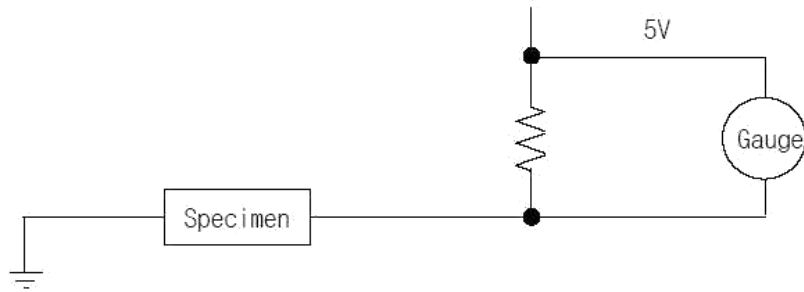

Fig. 4 Instant Cutoff

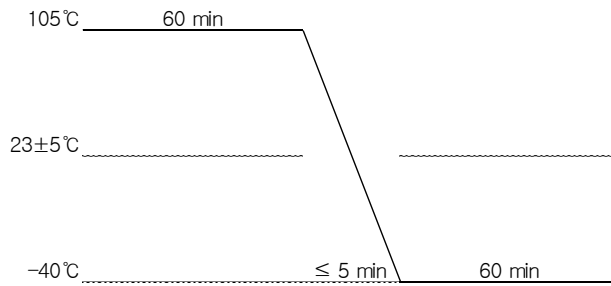

Fig. 5 Thermal Shock

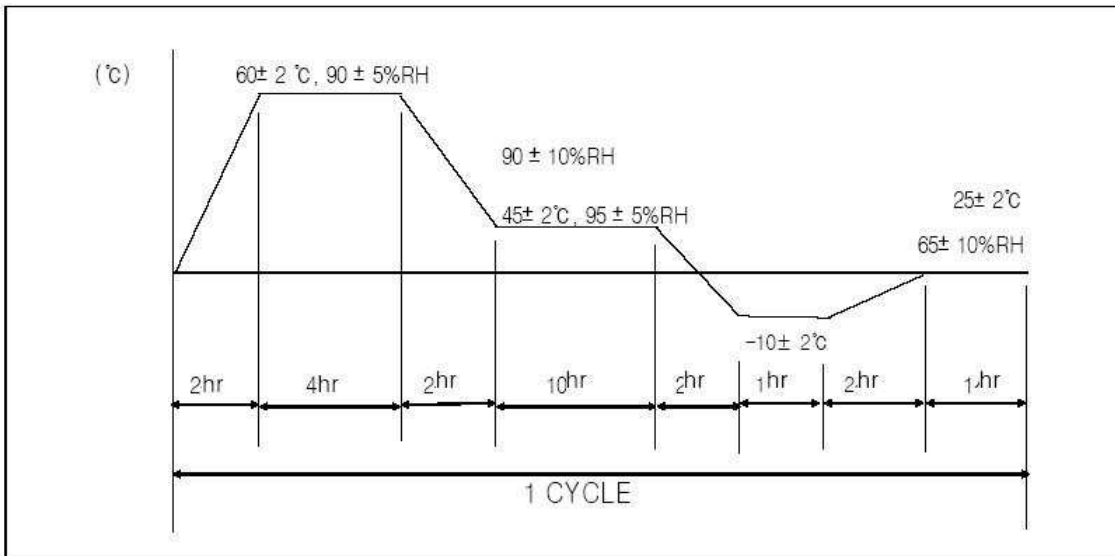

Fig. 6 Temp/Humidity